

EXPRESSION OF INTEREST

FOR

**SELECTION OF BACKEND TECHNOLOGY PARTNER/CONSORTIUM
PARTNER FOR EXECUTION IN TENDER FOR**

“DESIGN, SUPPLY, ERECTION, TESTING AND COMMISSIONING (DSETC) OF 75 M SELF SUPPORTING LATTICE STEEL TOWER INCLUDING PROVISIONS OF MOUNTINGS FOR INSTALLATION OF VHF FM ANTENNA ETC. FOR AKASHVANI FM STATION AT VELLORE, TAMILNADU”

EOI Ref No. BECIL/GM-1/AIR/75Mtr. Tower /2023-24

Dated: 22-03-2024

Issued By

(W B Prasad, General Manager)

 <p>बेसिल BECIL</p>	<p>Broadcast Engineering Consultants India Limited (A Government of India Enterprise) CIN No. : U32301UP1995GOI017744</p> <p><i>Corporate Office:</i> BECIL BHAWAN, C-56-A/17, Sector-62, Noida-201 307 Tel: 0120 4177850, Fax: 0120 4177879</p> <p><i>Head Office:</i> 14-B Ring Road, IP Estate, New Delhi- 110002 Tel: 011 23378823, Fax: 01123379885 Web: www.becil.com E-mail: rajender@becil.com</p>	 <p>G20 भारत 2023</p>
---	--	--

DISCLAIMER

The information contained in this Request for Proposal document (the “EOI”) or subsequently provided to Bidder(s), whether verbally or in documentary or any other form by or on behalf of BECIL or any of its employees or advisors, is provided to Bidder(s) on the terms and conditions set out in this EOI and such other terms and conditions subject to which such information is provided. This EOI is not an agreement and is neither an offer nor invitation by BECIL to the prospective Bidders or any other person. The purpose of this EOI is to provide interested parties with information that may be useful to them in making their offers (Bids) pursuant to this EOI. This EOI includes statements, which reflect various assumptions and assessments arrived at by BECIL in relation to the Project. Such assumptions, assessments and statements do not purport to contain all the information that each Bidder may require. This EOI may not be appropriate for all persons, and it is not possible for BECIL, its employees or advisors to consider the investment objectives, financial situation and particular needs of each party who reads or uses this EOI. Each Bidder should, therefore, conduct its own investigations, actual site/ facilities/location inspections and analysis and should check the accuracy, adequacy, correctness, reliability and completeness of the assumptions, assessments, statements and information contained in this EOI and obtain independent advice from appropriate sources. Information provided in this EOI to the Bidder(s) is on a wide range of matters, some of which may depend upon interpretation of law. The information given is not intended to be an exhaustive account of statutory requirements and should not be regarded as a complete or authoritative statement of law. BECIL accepts no responsibility for the accuracy or otherwise for any interpretation or opinion on law expressed herein. BECIL, its employees and advisors make no representation or warranty and shall have no liability to any person, including any Applicant or Bidder under any law, statute, rules or regulations or tort, principles of restitution or unjust enrichment or otherwise for any loss, damages, cost or expense which may arise from or be incurred or suffered on account of anything contained in this EOI or otherwise, including the accuracy, adequacy, correctness, completeness or reliability of the EOI and any assessment, assumption, statement or information contained therein or deemed to form part of this EOI or arising in any way for participation in this Bid Stage. BECIL also accepts no liability of any nature whether resulting from negligence or otherwise howsoever caused arising from reliance of any Bidder upon the statements contained in this EOI. BECIL may in its absolute discretion, but without being under any obligation to do so, update, amend or supplement the information, assessment or assumptions contained in this EOI. The issue of this EOI does not imply that BECIL is bound to select a Bidder or to appoint the Selected Bidder for the Project and BECIL reserves the right to reject all or any of the Bidders or Bids without assigning any reason whatsoever. The Bidder shall bear all its costs associated with or relating to the preparation and submission of its Bid including but not limited to preparation, copying, postage, delivery fees, expenses associated with any demonstrations or presentations which may be required by BECIL or any other costs incurred in connection with or relating to its Bid. All such costs and expenses will remain with the Bidder and BECIL shall not be liable in any manner whatsoever for the same or for any other costs or other expenses incurred by a Bidder in preparation or submission of the Bid, regardless of the conduct or outcome of the Bidding Process. In case of any rejection/cancellation, no bidder has any right to claim any compensation or reimbursement to cost. Participation in EOI does not guarantee selection of bidder.

TABLE OF CONTENTS

1. SECTION-I: INTRODUCTION AND BRIEF DESCRIPTION.....	4
2. SECTION-II: IMPORTANT DATES (SCHEDULE AND CRITICAL).....	7
3. SECTION-III: EOI NOTICE & GENERAL TERMS AND CONDITION.....	8
4. SECTION-IV: SCOPE OF WORK.....	13
5. SECTION-V: ELIGIBILITY CRITERIA AND EVALUATION.....	15
6. SECTION-VI: ENCLOSURES AND ANNEXURES.....	19
7. ANNEXURE A: PRE CONTRACT INTEGRITY PACT.....	19
8. ANNEXURE B: BANK MANDATE FORM.....	23
9. ANNEXURE C: PARTICULARS OF THE BIDDER.....	24
10. ANNEXURE D: ANNUAL TURNOVER AND NET WORTH.....	25
11. ANNEXURE E: PROFORMA OF LETTER OF UNDERTAKING.....	26
12. ANNEXURE F: BID COVERING LETTER.....	27
13. ANNEXURE G: CREDENTIALS SUMMARY.....	28
14. ANNEXURE H: SELF-DECLARATION FOR NON BLACKLISTING.....	29
15. ANNEXURE I: UNDERTAKING REGARDING PAYMENT OF GST.....	30
16. ANNEXURE J: PRE-BID AGREEMENT.....	31
17. ANNEXURE K: POWER OF ATTORNEY.....	40
18. ANNEXURE L:PRICE/UNPRICE BID FORMAT.....	42

SECTION –I

INTRODUCTION AND BRIEF DESCRIPTION

1. ABOUT BECIL

Broadcast Engineering Consultants India Limited (BECIL), an ISO 9001:2015, 27001:2013, ISO/IEC 2000:2012 certified Mini Ratna Central Public Sector Enterprise (CPSI) was incorporated on 24th March, 1995 under the Companies Act, 2013 (erstwhile the Companies Act, 1956) by Government of India with 100% equity share capital of BECIL held by President of India through Secretary and Joint Secretary of Ministry of Information & Broadcasting.

The Company was initially set up for providing project consultancy services and turnkey solutions encompassing the entire gamut of radio and television broadcast engineering, establishment of transmission facilities like content production facilities, terrestrial, satellite and cable broadcasting in India and abroad. The company has now diversified into the fields of Strategic Projects such as Information Communication.

Technology, Electronic Surveillance (namely CCTV, Access Control, Intrusion, Fire Safety, Hydrants, etc.). Electronic Media contents including films, Sentinel Analytics, Counter Drones/UAV etc. The activities include, but are not limited to Supply, Installation, Testing & Commissioning, Consultancy Services, Technical Audit, Media Analysis, R&D, projects pertaining to Digital India, City Surveillance, Safe City, Smart City, Make in India, Manufacturing, Audio Video & Data Analysis, Cyber Security, Engineering, Procurement & Construction, Project Management Services, Operation and Maintenance, Manpower Placement, AMC and providing total turnkey project for critical information infrastructure.

BECIL, has its Head Office in New Delhi, Corporate Office in Noida and Regional Office in Bangalore and Kolkata. BECIL is exploring geographical expansion in many states due to diversification in business portfolios.

Over the years, BECIL has consciously groomed and developed a team of in-house, versatile and dedicated engineers and also cultivated and harnessed a vast reservoir of professionals drawn from various fields of Broadcasting Industry, which include public and private Broadcasters, Defense and Cable Industry. Through this network of resourceful technical professionals, BECIL, has established its pan India presence to serve the needs of the industry.

BECIL has a vast reservoir of experts and integrates the expertise of All India Radio (AIR) and Doordarshan (DD), the national broadcaster of India, catering to one of the largest Radio Networks reaching out to more than a billion people and the world's largest Terrestrial Television Network supplemented by Analogue and Digital satellite Broadcasting services reaching out to millions of TV homes in India and abroad.

2. INTRODUCTION OF PROJECT/TENDER

The Additional Director General, All India Radio, AIR & Doordarshan, Swami Sivananda Salai, Chennai, has published tender No : ADG(E)(SZ)PUR/NIT-06/SRMST/2023-24 Date :14-02-2024 for “DESIGN, SUPPLY, ERECTION, TESTING AND COMMISSIONING (DSETC) OF 75 M SELF SUPPORTING LATTICE STEEL TOWER INCLUDING PROVISIONS OF MOUNTINGS FOR INSTALLATION OF VHF FM ANTENNA ETC. FOR AKASHVANI FM STATION AT VELLORE, TAMILNADU”.

3. INTENT AND IMPORTANT ASPECTS OF THE EXPRESSION OF INTEREST (EOI)

The Intent and important aspects of this Expression of Interest is (EOI) are as follows:-

(a) BECIL is interested to submit a competitive bid in response to the Client **Tender Number** ADG(E)(SZ)PUR/NIT-06/SRMST/2023-24 Date :14-02-2024 **having Last date of submission as 01-04-2024** floated Additional Director General, All India Radio, AIR & Doordarshan, Chennai).

(b) The intent of this EOI is to select an Implementation Agency/ System Integrator / Back end Technology partner of BECIL, for collaborating with BECIL for preparing a bid and participating in the above mentioned tender. A Pre-Bid Agreement will be signed by BECIL with the Implementation Agency/ System Integrator / Back end Technology partner selected through this EOI, for preparation of the bid and participation in the above mentioned tender. The format of Pre Bid Agreement is at **Annexure-J**.

(c) In case the bid submitted by BECIL against the Client **Tender Number** ADG(E)(SZ)PUR/NIT-06/SRMST/2023-24 Date :14-02-2024 , prepared in collaboration with the Implementation Agency/ System Integrator / Back end Technology partner selected through this EOI, is accepted and BECIL receives Work Order / Agreement from / with the Client, BECIL will issue a Work Order/Agreement to the selected agency. In such a scenario, the following conditions will be applicable, which are to be fully taken into consideration by the bidders, prior submitting a response to this EOI:-

(i) The Implementation Agency/ System Integrator / Back end Technology partner selected through this EOI, will have to sign a POST AWARD CONTRACT with BECIL, for undertaking the work as per the above mentioned Client's tender.

(ii) All terms and conditions of the Client's **Tender Number** ADG(E)(SZ)PUR/NIT-06/SRMST/2023-24 Date :14-02-2024 , and any subsequent amendments/ corrigenda thereof, will be applicable fully on back to back basis on the Implementation Agency/ System Integrator / Back end Technology partner selected through this EOI, including all important terms and conditions like, PBG, Payment Terms, SLA conditions, Liquidity Damages, and any other penalties etc.

(iii) Performance Bank Guarantee as applicable shall be payable by the selected bidder on back to back basis as per the terms and conditions of Client Tender, and any subsequent amendments/ corrigendum thereof.

(iv) In case the bidding against Client's Tender requires online payment for **EMD**, the proportionate amount will have to be paid in similar mode by the selected bidder

to BECIL. In case the bidding is on GeM portal or requires submission of EMD in the form of Bank Guarantee.. The cost incurred towards GeM transaction charges and/or EMD (BG) making charges shall also be recovered from the selected bidder in case the Project is awarded to BECIL by the client

(v) All payments in the Project to the selected agency, shall be on back-to-back basis only subject to receipt of corresponding payment from the client. No advance will be paid to the bidder, even though BECIL is eligible to get advance from the customer being a front end bidder, unless a BG of equivalent amount is submitted by the selected agency to BECIL.

(vi) The selected bidder, who has partnered with BECIL for a particular tender/project shall not partner with any other bidder for the same tender/project.

Bidders are advised to inspect the site and ascertain the conditions including leads/lifts involved /approach to vehicles, power, water geo political scenario etc. prior to submitting their bids. Their bid price shall be for completeness of system without any extra cost.

SECTION –II

1. IMPORTANT DATES (SCHEDULE AND CRITICAL DATES)

S.N.	ACTIVITY	SCHEDULED DATE & TIME
1.	EOI Number & Date	BECIL/GM-1/AIR/75Mtr. Tower /2023-24 Dated: 15-03-2024
2.	Date & Time of Issue of EOI	Date 22-03-2024 Time 15:00 Hrs
3.	Last date and Time for Submission of bids	Date 28-03-2024 Time 15:00 Hrs
4.	Place of Submission of EOI / Opening of EOI	BECIL Bhawan, C-56 / A -17, Sector - 62, Noida – 201 307,
5.	EOI Processing Fee (Non-refundable)	INR 15000/- + GST (Proof of submission to be submitted in BID)
7.	Security deposit/performance bank guarantee	Amount 3 % of contract /work order value (To be submitted by the successful bidder after issue of LOI)
8	Address for Communication of bids	BECIL Bhawan, C-56 / A -17, Sector - 62, Noida – 201 307.
9	Contact details for this EOI	Name : Rajender Singh Designation : Manager Telephone/ Mobile No : 8130190475 Email : rajender@becil.com

- NOTE: Broadcast Engineering Consultants India Ltd. reserves the right to amend the EOI tentative schedule and critical dates without giving any explanation whatsoever. Corrigendum may be published in this regard on www.becil.com . Bidders are advised to check the website for updates in this regard.

SECTION –III
EOI NOTICE & GENERAL TERMS AND CONDITION



1. EOI NOTICE

- 1.1 Broadcast Engineering Consultants India Limited (BECIL) invites Expression of Interest (EOI), through offline mode, for selection of an Implementation Agency/ System Integrator / Back end Technology partner of BECIL, for collaborating with BECIL for Collaborating with BECIL for preparing BID and Participating in the tender No **ADG(E)(SZ)PUR/NIT-06/SRMST/2023-24 Date :14-02-2024, floated by The Additional Director General, All India Radio, AIR & Doordarshan, Swami Sivananda Salai, Chennai, Chennai. (copy attached)**
- 1.2 **The duly signed Hard Copy of the Bid/ Techno Commercial Proposal is to be submitted in a packed and sealed envelop, in Tender Box, BECIL BHAWAN C-56/A 17 Sector 62 Noida (UP) 201307 .**
- 1.3 The EOI must be addressed to the given name and address:
**To,
Sh. W. B. Prasad
General Manager
Broadcast Engineering Consultants India Limited
C-56/A-17, Sector-62,Noida, Uttar Pradesh-201307**
- 1.4 The EOI must be submitted in English Only. All the documents including the supporting documents/enclosures etc. must be Calibri/Aerial/Times New Roman, font size-12 and fully legible. Supporting documents if in a language other than English must be accompanied by a English translated document. The English version shall prevail in matters of interpretation. Each and every page of the EOI should be numbered and mention the relevant page no. of the documents in the checklist. **EOI Documents which are not legible shall be rejected.**
- 1.5 The representative of agency will require a specific authorization/ board resolution to submit the EOI.
- 1.6 In case the bidder has any doubt about the meaning of anything contained in the EOI document, she/he shall seek clarification within 1 days of issue of EOI. Except for any written clarification by **Shri W. B. Prasad, General Manager BECIL**, no written or oral communication, presentation or explanation by any other employee of BECIL shall be taken to bind or fetter BECIL under the contract.
- 1.7 Bidders shall have to submit an amount of **Rs. 15,000/- + GST** through RTGS/ NEFT to BECIL (**Bank Mandate Form Enclosed at Annexure B**) towards the cost of EOI Document and no other mode of payment is acceptable. EOI Document is also available at BECIL Office: C-56/A-17, Sector-62, Noida, Uttar Pradesh-201307. The cost of EOI document is non-refundable.
- 1.8 The Management of BECIL reserves the right to amend or withdraw any of the terms and conditions mentioned in the EOI Document or reject any or all the bids without giving any notice or assigning any reason. The decision of the Director, Broadcast Engineering Consultants India Limited in this regard shall be final and binding on all.

- 1.9 BECIL reserve the right to amend any term of the EOI at any point of time before the submission and bidder should regularly check the website. Further, BECIL also reserves to increase/ decrease/ delete /add any BOQ item. Further any amendment done by client during the execution of work , all the amendment will be applicable. In case of non-acceptance of such amendment, the security deposit submitted will be forfeited by BECIL.
- 1.10 The bidder should submit the signed Integrity Pact on a plain paper along with the bid.
- 1.11 The Bidders will have no right to withdraw from the EOI process post submission of their bid without the formal consent of BECIL.

2. SUBMISSION OF EOI

- 2.1 EOI, complete in all respects, must be submitted offline.
 - 2.2 BECIL may, at its own discretion, extend the date for submission of EOI. In such a case all rights and obligations of BECIL and the Bidders shall be applicable to the extended time frame.
 - 2.3 As the EOI can be submitted only up to the defined date and time, there can't be any late bids. BECIL will not be responsible for any delay in obtaining the terms and conditions of the tender. BECIL will not be responsible for postal delays. Bids received after the due date will not be opened and rejected.
 - 2.4 At any time prior to the last date for receipt of EOI, BECIL may for any reason, whether at its own initiative or in response to a clarification requested by a prospective bidder, modify the EOI Document by an amendment. The amendment will be notified on BECIL's website <http://www.becil.com> and should be taken into consideration by the prospective bidders while preparing their EOI.
- 2.5 The EOI must contain:
- 2.5.1 Company/bidder profile relevant to EOI.
 - 2.5.2 It should also include details of past experience relevant to the "Scope of Work".
 - 2.5.3 Declaration regarding acceptance of Terms and conditions of EOI.
 - 2.5.4 Declaration of not been blacklisted by any of the Government agency.
 - 2.5.5 Essential information such as Name & address of the agency, Business Name, E-mail id, Fax No. /Telephone No. , Authorized Signatory name, E-mail ID and contact no.

- 2.6 The agency/ bidder/OEM/Implementation Agency shall ensure that it fulfills the eligibility criteria as desired in the EOI and other essential conditions. Compliance statement of Eligibility criteria with the documents submitted as a proof is to be prepared and submitted. The supporting documents may be with list of existing and past clients with details of services offered, details of similar projects executed.
- 2.7 The EOI should be duly signed on each page by authorized person. Each page should be properly numbered. Documents authorizing the signatory must accompany the EOI.
- 2.8 The EOI complete in all respects must be submitted with requisite information and annexure(s). The EOI should be free from ambiguity, change or interlineations. Incomplete EOI will not be considered and is liable to be rejected without making any further reference to agency/ bidder/OEM/Implementation Agency(s).
- 2.9 Bidders have to take into account any changes/amendments made in the end client's tender/RFP through corrigendum till date of submission of bid in response of EOI.
- 2.10 The bidder shall be ignored, if complete information is not given there-in, or if the particulars and data (if any) asked for are not filled in properly.

6.12	Checklist of documents/information to be submitted	
	(a)	Profile of the company/bidder/firm
	(b)	Certificate of Incorporation (for Company/LLP)
	(c)	Memorandum & Articles of Association/Partnership deed
	(d)	Audited financial statements for the last 3 financial years
	(e)	Income Tax Return Acknowledgment for last 3 assessment years
	(f)	Deleted
	(g)	Bid Security Declaration to be submitted by the MSME
	(h)	GST Registration Certificate or valid exemption certificate
	(i)	Copy of PAN Card
	(j)	Any other relevant registration documents on registration with other appropriate authorities (ESIC, EPFO, Labour Deptt etc.)
	(k)	Authorization letter in the bidder's letterhead authorizing the person signing the bid for this EOI as Power of Attorney (POA)
	(l)	Undertaking in letter head to indemnify BECIL from any claims / penalties / statutory charges, liquidated damages, with legal expenses etc.
	(m)	Bidders Details as per format
	(n)	All the requisite documents in the prescribed formats placed at Annexures to this EOI
	(o)	Pre-Contract Integrity Pact as per Annexure-A (a) "Bidders participating in the EOI have to agree to sign Integrity Pact on placement of order / contract" (b) "Those bidders who are not willing to sign Integrity Pact will not be considered for bid opening"
	(p)	All the documents in support of Technical criteria like Experience Certificates, PO, proposed Makes for the solution, Solution architecture (if asked) and other documents as required.
	(q)	Price Offer to BECIL as per Format of the EOI

3. OPENING OF EOI

- 3.1 The bids submitted against this EOI shall be opened on **Date 28-03-2024 at 15:30 Hrs.** BECIL reserves the right to change the date of opening of bid.
- 3.2 Bidders who wish to attend opening of EOI may visit BECIL for the same at the designated time, with authorization in proper format on bidder's letter head.

4. GENERAL TERMS & CONDITIONS OF EOI

- 4.1 The EOI Processing Fee, technical bid and financial bids are to be placed in separate sealed envelopes, super scribed with words "**EOI Processing Fee**", "**Technical Bid**" and "**Financial Bid**". All the three sealed envelopes as mentioned above are to be placed inside a single sealed envelope named as
"Response For EOI No. BECIL/GM-1/AIR/75Mtr. Tower /2023-24 Dated: 22-03-2024"
Submitted by: [Firm/Company name]
- 4.2 All bids are to remain valid for minimum of 180 days from the date of submission. BECIL reserve the right to seek the extension of bid validity.
- 4.3 BECIL reserves the right to solicit additional information from bidder/OEM/Implementation Agency to evaluate which bid best meets the need of the Project. Additional information may include, but is not limited to, past performance records, lists of available items of works which will be done simultaneously with the project, on-site visit and evaluations by BECIL personnel, or any other pertinent information. It will be vendor's responsibility to check for updated information on website <https://www.becil.com>. BECIL reserves the right to cross verify the information directly with client
- 4.4 BECIL reserves the right to waive off any deviations, accept the whole or part thereof or reject any or all bids and to select the bidder/OEM/Implementation Agency(s) which, in the ~~the~~ opinion of BECIL, best meets the project's interest. BECIL also reserves the right to negotiate with potential bidder/OEM/Implementation Agency(s) so that its best interest to fulfill the need of project is served.
- 4.5 BECIL reserves the right to reject any and all proposals, to negotiate all terms of any agreement resulting from this EOI, and to request additional information from bidder.
- 4.6 All information contained in this EOI, or provided in subsequent discussions or disclosures, is proprietary and confidential. No information may be shared with any other organization, including potential sub-contractors, without prior written consent of BECIL.
- 4.7 In case the agency selected through EOI goes into liquidation or undergoes a change in business/management, it will be intimated to BECIL & the selected agency will fulfill its commitment in case order is awarded to them. In case the selected agency is not able to perform, the work under reference will be done at risk & cost of the selected agency (successful bidder). PBG as the case may be will be forfeited by BECIL

4.8 Any dispute or difference or claim arising out of or in relation to this EOI, including the construction, validity, performance or breach thereof, shall be settled or decided by CMD/Director, BECIL or by any other person to be nominated by CMD/Director.

4.9 Intellectual Property Rights:

4.9.1 All deliverable, outputs, plans, drawings, specifications, designs, reports and other documents and software submitted by the bidders under this EOI and subsequent to this EOI in relation with this tender shall become and remain the property of BECIL/procuring entity and subject to laws of copyright and must not be shared with third parties or reproduced, whether in whole or part, without BECIL's/ the procuring entity's prior written consent.

4.9.2 The bidder shall, not later than upon termination or expiration of this EOI and/or subsequent Agreement/Contract signed with the bidder, deliver all such documents and software to BECIL/the procuring entity, together with a detailed inventory thereof.

4.9.3 The bidder may retain a copy of such documents and software but shall not use it for any commercial purpose.

4.10 The bidder shall submit an undertaking on their letter-head stating that:

“In reference to the Government of India, Ministry of Finance, Department of Expenditure, Office Memorandum No. F.No. 6/18/2019-PPD, Dated 23-07-2020. I hereby submit that:

“We have read the Clause regarding restrictions on procurement from a bidder of a country which shares a land border with India; We certify that we are not from such a country *or our beneficial owner is not from such a country or we will not sub-contract any work to a contractor from such countries*, if from such a country, have been registered with the Competent Authority.

We hereby certify that we fulfill all requirements in this regard and are eligible to be considered. [Where applicable, evidence of valid registration by the Competent Authority shall be attached.]”

4.11 The bidder needs to submit un-priced BOQ along with their technical bid.

4.12 The bidder needs to submit an Undertaking stating that: Vendors, whose Purchase Order(s) for any Project of BECIL was/were cancelled on risk & cost basis for non-performance or non- submission of performance guarantee in last 2 years, are not eligible to participate in this tender.

5 SIGNING OF NON-DISCLOSURE AGREEMENT

Bidders interested to participate in a EOI, where client requires signing of NDA, then bidder also have to sign a NON-DISCLOSURE AGREEMENT with BECIL on a non-judicial stamp-paper of Rs. 100, and the required EOI document fee has to be deposited to BECIL. Participation without compliance to above shall be invalid and such bids will not be considered by BECIL.

SECTION –IV SCOPE OF WORKS



6 GENERAL TERMS & CONDITIONS OF EOI

6.1 The EOI Processing Fee, technical bid and financial bids are to be placed in separate sealed envelopes, super scribed with words “**EOI Processing Fee**”, “**Technical Bid**” and “**Financial Bid**”. All the three sealed envelopes as mentioned above are to be placed inside a single sealed envelope named as

“Response For EOI No. BECIL/GM-1/AIR/75Mtr. Tower /2023-24 Dated: 22-03-2024 Submitted by: [Firm/Company name]”

6.2 All bids are to remain valid for minimum of 180 days from the date of submission. BECIL reserve the right to seek the extension of bid validity.

6.3 BECIL reserves the right to solicit additional information from bidder/OEM/Implementation Agency to evaluate which bid best meets the need of the Project. Additional information may include, but is not limited to, past performance records, lists of available items of works which will be done simultaneously with the project, on-site visit and evaluations by BECIL personnel, or any other pertinent information. It will be vendor’s responsibility to check for updated information on website <https://www.becil.com>. BECIL reserves the right to cross verify the information directly with client

6.4 BECIL reserves the right to waive off any deviations, accept the whole or part thereof or reject any or all bids and to select the bidder/OEM/Implementation Agency(s) which, in the sole opinion of BECIL, best meets the project’s interest. BECIL also reserves the right to negotiate with potential bidder/OEM/Implementation Agency(s) so that its best interest to fulfill the need of project is served.

6.5 BECIL reserves the right to reject any and all proposals, to negotiate all terms of any agreement resulting from this EOI, and to request additional information from bidder.

6.6 All information contained in this EOI, or provided in subsequent discussions or disclosures, is proprietary and confidential. No information may be shared with any other organization, including potential sub-contractors, without prior written consent of BECIL.

6.7 In case the agency selected through EOI goes into liquidation or undergoes a change in business/management, it will be intimated to BECIL & the selected agency will fulfill its commitment in case order is awarded to them. In case the selected agency is not able to perform, the work under reference will be done at risk & cost of the selected agency (successful bidder). PBG as the case may be will be forfeited by BECIL

6.8 Any dispute or difference or claim arising out of or in relation to this EOI, including the construction, validity, performance or breach thereof, shall be settled or decided by CMD/Director, BECIL or by any other person to be nominated by CMD/Director.

6.9 Intellectual Property Rights:

6.9.1 All deliverable, outputs, plans, drawings, specifications, designs, reports and other documents and software submitted by the bidders under this EOI and subsequent to this EOI in relation with this tender shall become and remain the property of BECIL/procuring entity and subject to laws of copyright and must not be shared with third parties or reproduced, whether in whole or part, without BECIL's/ the procuring entity's prior written consent.

6.9.2 The bidder shall, not later than upon termination or expiration of this EOI and/or subsequent Agreement/Contract signed with the bidder, deliver all such documents and software to BECIL/the procuring entity, together with a detailed inventory thereof.

6.9.3 The bidder may retain a copy of such documents and software but shall not use it for any commercial purpose.

6.10 The bidder shall submit an undertaking on their letter-head stating that:

"In reference to the Government of India, Ministry of Finance, Department of Expenditure, Office Memorandum No. F.No. 6/18/2019-PPD, Dated 23-07-2020. I hereby submit that:

"We have read the Clause regarding restrictions on procurement from a bidder of a country which shares a land border with India; We certify that we are not from such a country or our beneficial owner is not from such a country or we will not sub-contract any work to a contractor from such countries, if from such a country, have been registered with the Competent Authority.

We hereby certify that we fulfill all requirements in this regard and are eligible to be considered. [Where applicable, evidence of valid registration by the Competent Authority shall be attached.]"

6.11 The bidder needs to submit un-priced bid along with their technical bid.

6.12 The bidder needs to submit an Undertaking stating that: Vendors, whose Purchase Order(s) for any Project of BECIL was/were cancelled on risk & cost basis for non-performance or non-submission of performance guarantee in last 2 years, are not eligible to participate in this tender.

7 SIGNING OF NON-DISCLOSURE AGREEMENT

Bidders interested to participate in a EOI, where client requires signing of NDA, then bidder also have to sign a NON-DISCLOSURE AGREEMENT with BECIL on a non-judicial stamp-paper of Rs. 100, and the required EOI document fee has to be deposited to BECIL. Participation without compliance to above shall be invalid and such bids will not be considered by BECIL.

8 SCOPE OF WORK/SCHEDULE OF REQUIREMENTS

8.1 For detailed scope of work of the project & the Bill of Material, the bidders may refer the Client's Tender document, and it's amendments & corrigenda issued subsequently (if any); **Tender details references are as below and the same is also attached along with this EOI.**

(Bidders are instructed to check for any new corrigendum/amendments etc. before bidding)

Client's Tender Reference No: ADG(E)(SZ)PUR/NIT-06/SRMST/2023-24 Date :14-02-2024

SECTION-V



ELIGIBILITY CRITERIA AND EVALUATION

1. ELIGIBILITY CRITERIA OF BIDDERS

1.	<p><u>Company/Bidder's Profile:</u></p> <p>(a) The Bidder shall be Company/bidder incorporated /registered in India under Companies Act 1956/2013/ proprietorship/ partnership firm/ Limited Liability Partnership (LLP).</p> <p>(b) The bidder should have a valid PAN and GST Registration. Copy of PAN card and GST Registration certificate should be submitted in the bid.</p> <p>(c) The bidder should not be insolvent, in receivership, bankrupt or being wound up, not have had their business activities suspended and not be the subject of legal proceedings for any of the foregoing. An undertaking by the bidder should be submitted.</p> <p>(d) The Bidder should not be blacklisted/debarred/banned/restricted by any Union Govt./State Govt. / PSU as on date of submission of the Bid. "No-Conviction Certificate" duly signed by authorized signatory signing the bid, should be submitted.</p>
2.	<p><u>Financial Eligibility:</u></p> <p>(a) The bidder must submit last three financial year balance sheet/financial statement.</p> <p>(b) The bidder should have positive net worth in each of last three audited Financial Years.</p> <p>(c) Relaxed to MSME and startup companies subject to meet the technical eligibility criteria.</p>
3.	<p><u>Technical Eligibility Criteria:</u></p> <p>(i) Bidder (i.e. Single bidder / Indian Joint Venture company Incorporated) should have minimum 05 years of experience in providing Design, Supply, Erection, Testing and commissioning related works of '40 Meter & more self-supporting 3 or 4 legged Towers' (For MSME and startup companies, years of experience is not required subject to fulfill the following conditions)</p> <p>(ii) Bidder should have executed at least 02 or more number of job/contracts of following nature in last 03 (Three) years which should indicate in aggregation:</p> <p>Design supply, erection and commissioning of at least 1 (One) Nos of 40 Meter & more, self-supporting 3 or 4 legged Communication Towers OR Complete foundation work , tower construction and erection of at least 03(One) self-supporting three or four Legged communication towers with Height of 30 Mts or more.</p>

	To this effect, Bidder should submit copies of respective contracts, along with documentary evidence in respect of satisfactory execution of each of those contracts/ <u>satisfactory completion of relevant services</u> , in the form of copies of any of the documents (indicating respective contract number and type of services), such as - (i) Satisfactory completion / performance report (OR) (ii) proof of release of Performance Security after completion of the contract (OR) (iii) proof of settlement / release of final payment against the contract (OR) (iv) any other documentary evidence that can substantiate the satisfactory execution of each of the contracts cited above.
--	---

2. PRELIMINARY EVALUATION

- 2.1 BECIL shall evaluate the proposals to determine that they are complete, technically complying, no computational errors have been made, required documents as mentioned in the EOI have been furnished, the documents have been properly signed and the response is generally in order. In case of any calculation error, the total (final) price shall be considered for evaluation.
- 2.2 BECIL may waive off any minor infirmity or non-conformity or irregularity in the proposal which does not constitute a material deviation, provided such waiver does not prejudice or affect the relative ranking of any bidder/OEM/Implementation Agency.
- 2.3 In case only one bid is received or during the Technical Evaluation only one bidder/OEM/Implementation Agency qualifies for the next stage of the bidding process, BECIL reserves the right to accept/reject the bid.
- 2.4 In case two bids are received from the bidder, both the bids will be rejected.

3. EVALUATION PROCESS

- 3.1 No enquiry shall be made by the bidder/OEM/Implementation Agency (s) during the course of evaluation of the EOI, after opening of bid, till final decision is conveyed to the successful bidder/OEM/Implementation Agency(s). However, the Evaluation Committee/its authorized representative and office of BECIL can make any enquiry/seek clarification from the bidder/ OEM/ Implementation Agency(s), which the bidder/OEM/ Implementation Agency s must furnish within the stipulated time else the bids of such defaulting bidder/OEM/Implementation Agency(s) will be rejected. The proposal will be evaluated on the basis of its content, not its length.
- 3.2 The bidder/OEM/Implementation Agency s' proposals will be evaluated as per the requirements specified in the EOI and adopting the evaluation criteria spelt out in subsequent paras of this EOI document. The bidder/OEM/Implementation Agency are required to submit all required documentation as per evaluation criteria specified in EOI.

- 3.3 Upon verification, evaluation/ assessment, if in case any information furnished by the bidder/OEM/Implementation Agency is found to be Incomplete/incorrect, their bid will be summarily rejected and no correspondence on the same shall be entertained. Submission of false/forged documents will lead to forfeiture of security deposit and blacklisting of agency for a minimum period of 3 years from participating in BECIL tenders.
- 3.4 BECIL will review the proposal to determine whether the proposals are as per the requirements laid down. Proposals that are not in accordance with these requirements are liable to be disqualified at BECIL's discretion.
- 3.5 Evaluation of proposals shall be based on:
- 3.5.1 Information contained in the proposal, the documents submitted thereto and clarifications provided, if any.
 - 3.5.2 Experience and Assessment of the capability of the bidder/ OEM/ Implementation Agency based on past record.
- 3.6 BECIL reserves the right to seek any clarifications on the already submitted bid documents; however, no fresh documents shall be accepted in support of proposals. BECIL also reserves the right to cross verify the information with any agency.
- 3.7 Conditional proposals shall NOT be accepted on any ground and shall be rejected straightway. If any clarification is required by the bidders, the same should be obtained before submission of the proposals.
- 3.8 Even though bidder/OEM/Implementation Agency satisfy the necessary requirements they are subject to disqualification if they have:
- 3.8.1 Made untrue or false representation in the form, statements required in the EOI document.
 - 3.8.2 Records of poor performance such as abandoning work, not properly completing contract, financial failures or delayed completion.
- 3.9 The Financial Evaluation of the Bidders will be done only for those who qualify the Eligibility Criteria and other mentioned criteria of the Eoi.

4. FINANCIAL EVALUATION OF THE BIDS

The Bids will be financially evaluated as under:

Financial Bid Evaluation	
	Price and Margin Bid Format: A - Submit Lump sum Prices for supply and service items as per Schedule of Requirements (SoR) and Scope of Work (SoW) in INR (without Taxes) B - Quote margin to BECIL as a percentage of A [Minimum - 15%] C - Absolute value of Margin = A*B D - Overall Quoted price by bidder = A-C

- a) During evaluation, bidders with least “D” will be considered as **L1** and shall be declared the successful Bidder.
- b) The bid having higher value of “B” will be selected in case of two or more bidders have similar value of D.
- c) In case of a tie, the bidder who will be ready to offer higher value of “B” will be selected. In case the stalemate/ tie persists, Evaluation Committee of BECIL shall ask the bidders to conduct presentation on their proposed solution/understanding of the Project. Evaluation Committee will then select the bidder whose presentation will be the best, without giving any reasons/ justifications. The decision of Competent Committee of BECIL shall be final in this regard, and shall be abided by all bidders.
- d) If the bidder is selected, during the final tender submission, the price to be quoted to the Client shall not be more than price “A” and the margin offered to BECIL shall not be less than “B”.
- e) The decision of BECIL shall be final in this regard and cannot be challenged in any manner and also be abided by all the bidders.
- f) **L1** bidder may be called for further negotiations, if required.
- g) A Pre-Bid agreement shall be signed by BECIL with the successful declared **L1** bidder as per Pre-Bid Agreement placed at **Annexure-J**.

SECTION –VI
ENCLOSERS AND ANNEXURES

Annexure-A

PRE CONTRACT INTEGRITY PACT

Between

Broadcast Engineering Consultants India Limited (BECIL) hereinafter referred to as "Principal")

And

..... hereinafter referred to as "**The Bidder/Contractors**"

Preamble:

The Principal intends to award, under laid down organizational procedures, contracts **for**..... The Principal values full compliance with all relevant laws of the land, rule, regulations, economic use of resources and of fairness / transparency in its relations with its Bidder(S) and / Contractor(s).

In order to achieve these goals, the Principal will appoint an Independent External Monitor (IEM), who will monitor the tender process and the execution of the contract for compliance with the principles mentioned above.

Section 1 – Commitments of the Principal

1.1. The Principal commits itself to take all measures necessary to prevent Corruption and to observe the following principles: -

a) No employee of the Principal, personally or through family members, will in connection with the tender for, or the execution of a contract, demand, take a promise for or accept, for him/herself or third person, any material or Immaterial benefit which he/she is not legally be entitled to.

b) The Principal will, during the tender process treat all Bidder(s) with equity and reason. The Principal will in particular, before and during the tender process, provide to all Bidder(s) the same information and will not provide to any Bidder(s) confidential / additional information through which the Bidder(s) could obtain an advantage in relation to the tender process or the contract execution.

c) The Principal will exclude all known prejudiced persons from the process.

1.2. If the Principal obtains information on the conduct of any of its employees which is a criminal offence under the IPC/PC Act, or if there be a substantive suspicion in this regard, the Principal will inform the Chief Vigilance Office and in addition can initiate disciplinary actions.

Section 2 – Commitments of the Bidder(s)/ Contractor(s)

2.1. The bidder(s) Contractor(s) commits himself to take all measures necessary to prevent corruption. He commits himself to observe the following principles during his participation in the tender process and during the contract execution.

a) The Bidder(s) Contractor(s) will not, directly or through any other person or firm, offer, promise or give to any of the Principal's employees involved in the tender process or the execution of the contract/ or to any third person any material or other benefit which he/she is not legally entitled to, in order to obtain in exchange any advantage of any kind whatsoever during the tender process or during the execution of the contract.

b) The Bidder(s) Contractor(s) will not enter with other Bidder(s) into any undisclosed agreement or understanding, whether formal or informal. This applies in particular to prices, specifications, certifications, subsidiary contracts, submission or non-submission of bids or any other actions to restrict competitiveness or to introduce cartelization in the bidding process.

c) The Bidder(s) Contractor(s) will not commit any offence under the relevant IPC/PC Act; further the Bidder(s) Contractor(s) will not use improperly, for purposes of competition or personal gain, or pass on to others, any information or document provided by the Principal as part of the business relationship, regarding plans, technical proposals and business details, including information contained or transmitted electronically.

d) The Bidder(s) Contractor(s) of foreign origin shall disclose the name and address of the Agents/ representatives in India, if any. Similarly, the Bidder(s) Contractor(s) of Indian Nationality shall furnish the name and address of the foreign principals, if any. Further details as mentioned in the "Guidelines on Indian Agents of Foreign Suppliers" Shall be disclosed by the Bidder(s) / Contractor(s). Further, as mentioned in the Guidelines all the payments made to the Indian agent/ representative have to be in Indian Rupees only.

e) The Bidder(s) Contractor(s) will, when presenting himself, disclose any and all payments he has made, is committed to or intends to make to agents, brokers or any other intermediaries in connection with the award of the contract/Agreement.

2.2. The Contractor(s) will not instigate third persons to commit offences outlined above or be an accessory to such offences.

Section 3 – Disqualification from tender process and exclusion from future contracts

If the Bidder(s) Contractor(s), before award or during execution has committed a transgression through a violation of Section 2, above or in any other form such as to put his reliability or credibility in question, the Principal is entitled to disqualify the Bidder(s) Contractor(s) from the tender process or take action as per the defined procedure.

Section 4 – Compensation for Damages

4.1. If the Principal has disqualified the contractor from the tender process prior to the award according to Section 3, the Principal is entitled to demand and recover the damages Equivalent to Earnest Money Deposit / Bid Security.

4.2. If the Principal has terminated the contract according to Section 3, or if the Principal is entitled to terminate the contract according to section 3, the Principal shall be entitled to demand and recover from the Contractor liquidated damages of the contract value or the amount equivalent to Performance Bank Guarantee.

Section 5 – Previous transgression

5.1. The Bidder(s) contractor declares that no previous transgression occurred in the last 3 years with any other Company in any country conforming to the Anti-corruption approach or with any other Public Sector Enterprise in India that could justify his exclusion from the tender process.

5.2. If the contractor makes incorrect statement on this subject, he can be disqualified from the tender process or action can be taken as per the procedure mentioned in “Guidelines on Banking of business dealings”.

Section 6 – Equal treatment of all Bidders/Contractors/Subcontractors

6.1. The Bidder(s) Contractor(s) undertake(s) to demand from all subcontractors a commitment in conformity with this Integrity Pact and to submit it to the Principal before contract signing.

6.2. The Principal will enter into agreement with identical conditions as this one with all Bidders, Contractors and Subcontractors.

6.3. The Principal will disqualify from the tender process all bidder who do not sign this Pact or violate its provisions.

Section 7 – Criminal charges against violating Bidder(s)/ Contractor(s)/Subcontractor(s)

If the Principal obtains knowledge of conduct of a Bidder, Contractor or Subcontractor, or of an employee or a representative or an associate of a Bidder, Contractor or Subcontractor, which constitutes corruption, or if the Principal has substantive suspicion in this regard, the Principal will inform the same Chief Vigilance Office.

Section 8 – External Independent Monitor/Monitors

8.1. Principal appoints competent and credible Independent External Monitor for this Pact. The task of the Monitor is to review independently and objectively, whether and to what extent the parties comply with the obligations under this agreement.

8.2. The Monitor is not subject to instructions by the representatives of the parties and performs his functions neutrally and independently. He reports to the CMD of M/s Broadcast Engineering Consultants India Limited (BECIL).

8.3. The Bidder(s)/Contractor(s) accepts that the Monitor has the right to access without restriction to all Project documentation of the Principal including that provided by the Contractor. The Contractor will also grant the Monitor, upon his request and demonstration of a valid interest, unrestricted and unconditional access to his project documentation. The same is applicable to Subcontractors. The Monitor is under contractual obligation to treat the information and documents of the Bidder(s)/Contractor(s)/Subcontractor(s) with confidentiality.

8.4. The Principal will provide to the Monitor sufficient information about all meetings among the parties related to the Project provided such meetings could have an impact on the contractual relations between the Principal and the Contractor. The parties offer to the Monitor the option to participate in such meetings.

8.5. As soon as the Monitor notices, or believes to notice, a violation of this agreement, he will so inform the Management of the Principal and request the Management to discontinue or take corrective action, or to take other relevant action. The monitor can in this regard submit nonbinding recommendations. Beyond this, the Monitor has no right to demand from the parties that they act in a specific manner, refrain from action or tolerate action.

8.6. The Monitor will submit a written report to the Chairperson of the Board of the Principal within 8 to 10 weeks from the date of reference or intimation to him by the 'Principal' and, should the occasion arise, submit proposals for correcting problematic situations.

8.7. If the Monitor has reported to the CMD of the BECIL, a substantiated suspicion of an offence under relevant APC/PC Act, and the Chairman BECIL has not, within reasonable time, taken visible action to proceed against such offence or reported it to the Chief Vigilance Office, the Monitor may also transmit this information directly to the Central Vigilance Commissioner, Government of India.

8.8. The word 'Monitor' would include both singular and plural.

Section 9 – Pact Duration

This Pact begins when both parties have legally signed it. It expires for the Contractor 20 months after the last payment under the contract, and for all other Bidders 6 months after the contract has been awarded. If any claim is made/lodged during this time, the same shall be binding and continue to be valid despite the lapse of this pact as specified above, unless it is discharged/ determined by CMD, M/s. Broadcast Engineering Consultants India Limited.

Section 10 – Other provisions

10.1. This agreement is subject to Indian Law. Place of performance and jurisdiction is the head office of the Principal, i.e., New Delhi.

10.2. Changes and supplements as well as termination notices need to be made in writing. Side agreement have not been made.

10.3. If the Contractor is a partnership or a consortium, this agreement must be, signed by all partners or consortium members.

10.4. Should one or several provisions of this agreement turn out to be invalid, the remainder of this agreement remains valid. In this case, the parties will strive to come to an agreement to their original intentions.

FOR AND ON BEHALF OF CONTRACTOR

FOR AND ON BEHALF OF PRINCIPAL



ANNEXURE B (BANK MANDATE FORM)

- DETAILS FOR PAYMENT OF TENDER PROCESSING FEES



यूनियन बैंक ऑफ इंडिया **Union Bank of India**

एक भारत श्रेयते A Government of India Undertaking

(A Govt. of India Undertaking)
 MID CORPORATE BRANCH, DELHI SOUTH
 D -26-28, Connaught Place, NEW DELHI -110001
 Tel: +91-9137849790; Fax: 01-11 23414330 ; Swift: UBININBBNDL
 Email: ubin0549797@unionbankofindia.bank

Ref.: MCB:ADV:ATL:2022-23: Date: 18.01.2023

TO WHOMSOEVER IT MAY CONCERN

A	Name of the Beneficiary	BROADCAST ENGINEERING CONSULTANTS INDIA LIMITED
i	Address with Pin Code	BECIL Bhawan, C-56/A17, Sector -62, Noida - 201307 (U.P)
ii	Permanent Account Number (PAN)	AAACB2575L
iii	(a) Telephone No.	0120-4177861
	(b) Fax Number	0120-4177879
	(c) Contact Person	Sh. Awadhesh Pandit General Manager - (Finance and Accounts)
	(d) E-mail Address	panditmd@becil.com
	(e) Mobile No.	+91-8130918866
B	Bank Particulars	
i	Bank Name	UNION BANK OF INDIA
ii	Bank Contact No	+91-9137849790
iii	Branch Address with Pin Code	26/28, 1 st Floor, D Block, Connaught Place, New Delhi, 110001.
iv	BSR Code	549797
v	MICR	110026046
vi	SWIFT CODE	UBININBBNDL
vii	11 Character IFSC Code of the Bank (Either enclosed a cancelled Cheque or obtain Bank Certificate as appended)	UBIN0549797
VIII	Bank Account Number as appearing on the Cheque Book	565101000065461
ix	Bank Account Type	Overdraft
X	If other, Specify	--

**This certificate is issued on the specific request of our customer without any risk and responsibility on the part of the bank or any of its employees.*



Bank Stamp with Authorized Signatory
 Date 20-01-2023

Page 1 of 1

Particulars of The Bidder

1.	Name of company/bidder	
2.	Office Address /Telephone No / Fax No / email id / website	
3.	Year of establishment	
4.	Status of the Company/bidder	
5.	Name of Directors	i) ii) iii)
6.	Names of principle person concerned with this work with title and Telephone No / Fax/ Email Id, Etc.	
7.	Whether registered with the registrar of companies /registrar of firms. If so, mention number and date.	i) ii) iii)
8.	In case of change of Name of the Firm, former Name / Names and year/ years of establishment:	
9.	GST registration certificate	
10.	Whether an assessed of income tax. If so, mention permanent account number.	
11.	State Annual turnover of the company/bidder Furnish copies of audited balance sheet and profit & loss account (audited) for the last three years.	
12.	Particulars and place of similar type of works done in a single order. (Furnish details in a separate sheet and enclose copy of the employers certificate)	
13.	Specify the maximum value of single work executed in the past three years.	
14.	Status and details of disputes/ litigation/ arbitration, if any.	

Signature of Authorized Signatory

Place: _____

Date: _____

Address: _____

Mobile: _____

Email ID: _____

Annual Turnover & Net worth

(To be printed on implementing agency's letterhead and signed by Authorized signatory.)

To
The General Manager
Broadcast Engineering Consultants India Limited
BECIL Bhawan, C-56, A/17, Sector-62, Noida-201307

Full Name of Bidder (Supplier) entity:

Full Address of Bidder (Supplier) entity:

S. No.	Financial Year	Turnover of Bidder	Net worth	Remarks
1	2020-21			
2	2021-22			
3	2022-23			
	Average			

*Enclose Audited Balance sheets only.

Note: The required certificate from CA with UDIN No. is enclosed along with this form.

Signature of Authorized Signatory

Place: _____

Date: _____

Address: _____

Mobile: _____

Email ID: _____

Performa of letter of Undertaking for Bid Validity

To
General Manager
Broadcast Engineering Consultants India Limited
BECIL Bhawan, C-56, A/17, Sector-62, Noida-201307

Reference: EOI No. <<>> dated << 202X>>

I/We hereby submit our Bid and undertake to keep our Bid valid for the period of 180 days from the date of submission of the Bid.

I/We also agree to abide by and fulfill all the terms, conditions of provision of the bid document.

Signature of Authorized Signatory

Place: _____

Date: _____

Address: _____

Mobile: _____

Email ID: _____

Bid Covering Letter

To
General Manager
Broadcast Engineering Consultants India Limited
BECIL Bhawan, C-56, A/17, Sector-62, Noida-201307

Reference: EOI No.<<>> dated << 202X>>

Dear Sir/Madam,

We, the undersigned, offer to provide Systems Implementation solutions to the Purchaser on <Name of the Systems Implementation engagement> with your Expression of Interest dated <insert date>and our Proposal. We are hereby submitting our Proposal, which includes our Technical bid sealed on the <URL of e-Procurement portal> portal.

We hereby declare that all the information and statements made in this Technical bid are true and accept that any misinterpretation contained in it may lead to our disqualification.

We undertake, if our Proposal is accepted, to initiate the Implementation services related to the assignment not later than the date indicated in Fact Sheet.

We agree to abide by all the terms and conditions of the EOI document. We would hold the terms of our bid valid for <180> days as stipulated in the EOI document.

We understand you are not bound to accept any Proposal you receive.

Signature of Authorized Signatory

Place: _____

Date: _____

Address: _____

Mobile: _____

Email ID: _____

Credentials Summary

S. No.	Project Name	Client Name	Client Type	Project Value (in INR)	Documentary evidence provided (Yes or No)	Project Status (Completed or Ongoing or Withheld)
1						
2						
3						
4						
5						
6						
7						
8						
9						
10						

Signature of Authorized Signatory

Place: _____

Date: _____

Address: _____

Mobile: _____

Email ID: _____

Self-Declaration For Non Black Listing

[ON BIDDER'S LETTER HEAD]

Bidder Ref. No.

Dated :

To
General Manager
Broadcast Engineering Consultants India Limited
BECIL Bhawan, C-56, A/17, Sector-62, Noida-201307

We, M/s. ----- hereby declare that the firm/company namely M/s. -----
----, as on the date of bid submission, has not been blacklisted or debarred by any of the Central Government
or State Government or any organization under Central/ State Government or any Statutory Authority, or any
Public- Sector Undertaking.

M/s has not been found guilty of any criminal offence by any court of law in India or abroad.
M/s, its directors and officers have not been convicted of any criminal offence related to their
professional conduct or the making of false statement or misrepresentations as to their qualifications to enter
into procurement contract within a period of three years preceding the commencement of the procurement
process or have not been otherwise disqualified pursuant to debarment proceedings.

Yours faithfully

For,

Signature of Authorized Signatory

Place: _____

Date: _____

Address: _____

Mobile: _____

Email ID: _____

Undertaking Regarding Payment Of GST/ Filing Of GST Return

Ref.....

Date

To,
The Chairman and Managing Director,
Broadcast Engineering Consultants India Limited,
56-A/17, Block-C, Sector-62, Noida-201307 (U.P.)

Subject: Undertaking regarding Payment of GST/ Filing of GST Return

Dear Sir,

This is in connection to the works awarded by M/s Broadcast Engineering Consultants India Limited (BECIL), we hereby undertake that we will comply with Goods and Services Tax 2017 and subsequent amendment and Various Rules Relating to GST Act, 2017 (herein after referred to as GST Act and Rules) wherever we are obliged to comply with the GST Act and GST Rules.

We further hereby undertake that we will issue proper **“Tax Invoice”** and/or any other Relevant Document as required under GST Act and Rules. We will furnish appropriate GST return and pay GST as required under GST Act and Rules on timely basis and will provide GST credit on timely basis through GST Portal (and/or by any other means as provided by GST Act and Rules).

We hereby certify & undertake that we will not alter, delete or modify the tax invoices and other details uploaded at GST Portal unless approved by BECIL in writing. We hereby certify all the relevant document along with tax invoice as the case may be

We also hereby certify & undertake that we indemnify BECIL on account of any loss of GST input credit as well as any interest, penalty, demands or other costs, expenses suffered by BECIL because of any failure on our part to file appropriate Return on time and/or pay Tax to Government/Appropriate Authority.

In case we do not make payment the tax/interest/penalty/other expenses etc. on demand raised by Government/Tax Authorities due to default/delay on our part/action, we also authorize BECIL to forfeit/deduct from security held by BECIL, equivalent amount of interest/penalty/tax etc. for the amount so withheld.

Signature of Authorized Signatory on behalf of Agency

Address: _____

Mobile: _____

Email ID: _____

PRE-BID AGREEMENT

This Agreement is made at NOIDA on __ March 2024 between:

M/s. Broadcast Engineering Consultants India Limited, Mini Ratna Public Sector Enterprise of the Government of India having its Registered Office at 56-A/17, Block-C, Sector-62, Noida -201301 (U.P.) and Head Office at 14-B IP Estate Ring Road, New Delhi -110002 acting through Sh W.B. Prasad, General Manager (hereinafter referred to as "**BECIL**" or "**First Party**") which expression shall unless repugnant to the context or meaning thereof, include its successors, authorized representatives and permitted assigns as the First Party. **BECIL** represents that it is an ISO 9001:2015, 27001:2013, ISO/IEC 20000:2012 certified, Mini Ratna Public Sector Enterprise of the Government of India and provides project consultancy services and turnkey solutions encompassing the entire gamut of radio and television broadcast engineering viz content production facilities, terrestrial, like satellite and cable broadcasting in India and abroad. It also undertakes supply of specialized communication, monitoring, security and surveillance system to Defense, Police department and various Para-military forces. **BECIL** has specialization in executing TV/Radio broadcasting, IT networking, Security Surveillance, Audio Video and Access control system projects in various Govt. departments throughout the country by its team of intelligent and dedicated technical officers and staff

AND

M/s XXX Company/firm incorporated under Companies Act, 1956 having its Registered Office at **YYY** by **Mr. XYZ**, Managing Director (hereinafter referred to as "**XX**" or "**Second Party**") which expression shall, unless repugnant to the context or meaning thereof, include its successors, authorized representatives and permitted assigns as the Second Party. **XX** represents that it is a company/firm which has

BECIL and XX individually referred to as "**Party**" and jointly as "**Parties**".

PREAMBLE

A) WHEREAS (Hereinafter referred as "**CUSTOMER**" or "**END CUSTOMER**") floated Tender Number: ADG(E)(SZ)PUR/NIT-06/SRMST/2023-24 Date :14-02-2024 for DESIGN, SUPPLY, ERECTION, TESTING AND COMMISSIONING (DSETC) OF 75 M SELF SUPPORTING LATTICE STEEL TOWER INCLUDING PROVISIONS OF MOUNTINGS FOR INSTALLATION OF VHF FM ANTENNA ETC. FOR AKASHVANI FM STATION AT VELLORE, TAMILNADU published on E- Procurement PORTAL. (Hereinafter referred as "**RFP**")

B) That BECIL intends to submit its bid as in response to this RFP and it may by means of contracts and agreements enter into AGREEMENT with bidder of the related technology for the purpose of this RFP.

C) **AND WHEREAS** BECIL has floated an EOI no. BECIL/GM-1/AIR/75Mtr. Tower /2023-24 Dated: 22-03-2024 (hereinafter referred to "EOI") for selection of *System Integrator/Consortium Partner/Back-end Technology Partner/Implementation Agency*.

D) **AND WHEREAS** XX has been selected as *System Integrator/Consortium Partner/Back-end Technology Partner/Implementation Agency* of BECIL through terms of EOI. Also XX agrees to execute entire scope of work for above mentioned Customer's RFP, if the bid submitted by BECIL against the RFP is accepted, and if BECIL receives a Work Order for the same. This agreement has been put into effect from date of signing of this agreement on an exclusive basis.

E) **AND WHEREAS** the purpose of this pre bid agreement is to formalize an understanding between BECIL and XX for RFP. Tender, if awarded to BECIL will be called as "Project".

F) **AND WHEREAS** both the parties agreed to work together for preparation and submission of the Bid against the Customer's RFP and in case of award of work to BECIL, execute the work

NOW THIS AGREEMENT WITNESSETH AS FOLLOWS:

ARTICLE 1. GENERAL

1.1 PURPOSE

A) **WHEREAS**, End Customer has floated Tender Number: ADG(E)(SZ)PUR/NIT-06/SRMST/2023-24 Date :14-02-2024 for DESIGN, SUPPLY, ERECTION, TESTING AND COMMISSIONING (DSETC) OF 75 M SELF SUPPORTING LATTICE STEEL TOWER INCLUDING PROVISIONS OF MOUNTINGS FOR INSTALLATION OF VHF FM ANTENNA ETC. FOR AKASHVANI FM STATION AT VELLORE, TAMILNADU .

B) XX has agreed to associate itself and render its services to BECIL in the capacity of *System Integrator/Consortium Partner/Back-end Technology Partner/Implementation Agency* for the purpose of the aforesaid RFP enabling BECIL to bid for the RFP.

C) Both the parties have read and understood the terms of the aforesaid RFP. Second Party has agreed not to disclose the terms of the aforesaid RFP to anyone unless so authorized to do so by the First Party. The PARTIES will execute the PROJECT, if awarded, in terms of responsibility as ascribed to each party. XX will do the entire system integration for the project, if awarded which covers the entire scope of work mentioned in the tender RFP documents or any subsequent modifications/amendments thereof. BECIL undertakes to be responsible for all overall Project Management and correspondence/ interface/ interaction with the Customer.

1.2 REPRESENTATION OF PARTIES

Second Party represents to the First Party that as on date of

(a) That Second Party is duly organized, validly existing and in good standing under the laws of its incorporation and

has all requisite power and authority to enter into this Contract.

- (b) That the execution, delivery and performance by Second Party of this Contract have been authorized by all necessary and appropriate corporate or governmental action and will not to the best of its knowledge:
- (i) Require any consent or approval not already obtained;
 - (ii) Violate any Applicable Law presently in effect and having applicability to it;
 - (iii) Violate the Agreement and articles of association, bye-laws or other applicable organizational documents thereof;
 - (iv) Violate any clearance, permit, concession, grant, license or other governmental authorization, approval, judgment, order or decree or any mortgage Contract, indenture or any other instrument to which Second Party is a party or by which Second Party or any of its properties or assets are bound or that is otherwise applicable to Second Party;
 - (v) Create or impose any license, mortgages, pledges, claims, security interests, charges or Encumbrances or obligations to create a lien, charge, pledge, security interest, encumbrances or mortgage in or on the property of such Party, except for encumbrances that would not, individually or in the aggregate, have a material adverse effect on the financial condition or prospects or business of Second Party so as to prevent such Party from fulfilling its obligations under this Contract;
- (d) That Second Party has not been black-listed by Central/ State Government or any other Government PSU and are not facing/likely to face any disciplinary proceedings under Indian or under laws of any other country.
- (e) That this Contract, RFP No. _____ Dated _____ and the NOA issued by BECIL dated _____ is the legal and binding obligation of such Party, enforceable in accordance with its terms against it;
- (f) That there is no litigation pending or, to the best of Second Party's knowledge, threatened to which it or any of its Affiliates is a party that presently affects or which would have a material adverse effect on the financial condition or prospects or business of such Party in the fulfilment of its obligations under this Contract.
- (g) That there is no legal action/dispute initiated or pending on Second Party at the time of signing of this contract which is likely to concern or affect BECIL in any manner. If any such case is found pending, the contract will automatically become invalid and the agency will be penalized by withholding the EMD, PBG and legal action will be initiated as deemed fit by the competent authority. All ongoing and future business association with BECIL will also be terminated.

1.3 RESPONSIBILITY MATRIX

P-Primary Responsibility

S-Secondary Responsibility

J- Joint Responsibility

S.NO.	PRE-BID RESPONSIBILITY	BECIL	XX
1.	Pre bidding site survey, if any	P	S
2.	Technical bid preparation as per RFP along with MAF and datasheets of fully complied products as per the RFP specifications.	J	J
3.	Competitive commercial bid preparation as per RFP	S	P
4.	Coordination with OEMs/distributors for preparation of bid.	S	P
5.	Technical Bid Facilitation.	S	P
6.	Commercial Bid Facilitation	S	P
7.	Prepare the bid as per eligibility criteria. Interaction with customer and going through the RFP process.	P	S
8.	Documentation and correspondence with the customer.	P	-
9.	Provisioning of certificates from OEMs for product support, warranty, spare availability and delivery as per the customer/ RFP requirement.	-	P
10.	Provisioning of EMD to end customer as per RFP requirement.	P	-
11.	Delete		
12.	Provisioning of any other required document for bidding.	J	J
13.	Submission of complete techno-commercial offer to the customer in requisite mode.	P	
14.	Execution of field trials and any product demonstrations and tests, as required by the customer.	S	P
15.	Any other relevant follow up, correspondence and meetings with customer.	P	S
16.	Support during Reverse Auction (if any)	S	P

NOTE: A detailed Agreement of POST-BID responsibility shall be signed subsequently, if the project is awarded and Work Order issued by the Customer to BECIL.

1.4 The detailed Agreement for **selected bidder** between the parties will contain:

(a) Responsibility matrix of the PARTIES to execute the PROJECT, if awarded, jointly. This will covers the entire scope of work mentioned in the tender RFP documents or any modifications thereof.

(b) Other Modalities/conditions that might arise or might require to be incorporated towards complete & satisfactory execution of the Project.

The above list is illustrative and not exhaustive and will include apart from the above other clauses also.

(c) Financial Arrangements.

The above list is illustrative and not exhaustive and will include apart from above other clauses also.

ARTICLE 2:- TERM AND TERMINATION

2.1. **Terms:** This AGREEMENT shall be valid from the date of signing and shall terminate on the earliest occurrence of one of the following:

a) A Contract for the PROJECT has been awarded by the End Customer to **BECIL** and the parties hereto have subsequently entered into and signed a comprehensive formal AGREEMENT referred to under item **1.4** above;

or

b) In case the Contract for the PROJECT is awarded to other entity/bidder or the PROJECT is cancelled and all rights and obligations between the PARTIES hereto according to this AGREEMENT have been fulfilled;

or

c) By Mutual consent between the Parties

2.2. In the event order is placed on BECIL by the end customer wherein BECIL is to use services of XX, XX will have no right to terminate this agreement till such time that the project is complete in all respects including the expiration of AMC period, if any.

2.3 **Effect of Termination or Expiration:** Upon any expiration or termination of this AGREEMENT and subject to applicable laws; Each party will (i) return (or destroy if requested by the disclosing party) the original and all copies of any confidential & proprietary information of the disclosing party; and (ii) at the disclosing party's request, have one of the officers of the receiving party certify in writing that it has fully complied with the provisions of this Clause. For the purpose of this Clause, the expression "Confidential & Proprietary Information" shall be limited to matters of commercial confidence, Proprietary rights, trade and business secrets and intellectual property but shall not include correspondence exchanged between the parties and contents thereof.

ARTICLE 3:- PAYMENT & COMMERCIAL TERMS AND CONDITIONS

3.1 While preparation and submission of Bid against the Client's RFP, BECIL will Provision the ~~EMD~~ to end customer as per the customer RFP requirement.

3.2 In case the bid submitted by BECIL against the Customer's RFP, prepared in collaboration with XX, is accepted and BECIL receives Work Order from the Customer, the following conditions will be applicable:-

- (i) BECIL will provision Transaction charges, Annual Milestone charge and any other charges for signing the agreement with the customer, payable to GEM.
- (ii) BECIL will issue Work/Supply Order/s to XX, on becoming L1, on which BECIL will add a suitable profit margin to BECIL on the total basic value of the project

- (iii) All terms and conditions of the Customer's RFP, and any subsequent amendments/ corrigendums thereof, will be applicable fully on back to back basis on XX, including all important terms and conditions like EMD, PBG, Payment Terms, SLA conditions, Liquidity Damages, and any other penalties etc.
- (iv) EMD and Performance Bank Guarantee as applicable shall be payable by XX on back to back basis as per the terms and conditions of Customer's RFP, and any subsequent amendments/ corrigendums thereof.
- (v) In case the bidding against Customer's RFP requires online payment for EMD, the proportionate amount will have to be paid in similar mode by XX to BECIL. In case the bidding is on GeM portal or requires submission of EMD in the form of Bank Guarantee.. The cost incurred towards GeM transaction charges and/or EMD (BG) making charges shall also be recovered from XX in case the Project is awarded to BECIL by the Customer.
- (vi) All payments in the Project to XX, shall be on back-to-back basis only subject to receipt of corresponding payment from the Customer. No advance will be paid to XX, even though BECIL may be eligible to get advance from the customer being a front end bidder, unless a BG of equivalent amount is submitted by XX to BECIL.
- (vii) All pricing by XX would be inclusive of all statutory taxes payable by XX. However any statutory change in Tax Structure prevailing at the time of invoicing shall be binding to both - XX and BECIL. Their bid price shall be for completeness of system without any extra cost.

ARTICLE 4: CONFIDENTIAL INFORMATION

4.1. Subject to applicable laws and as required by End-Customer, Law-Enforcement agencies & Government agencies, the terms of this AGREEMENT are agreed by all the Parties to be confidential and all information disclosed by one party to each other hereunder shall be kept strictly confidential.

4.2. Each party shall keep any information obtained by it from the other party strictly private and confidential for the purpose of:

- (a) preparation of bid for the tender and/or,
- (b) In case of award of a Contract for the PROJECT to BECIL and/or,
- (c) Execution of the PROJECT

ARTICLE 5: LIMITATION OF LIABILITY

5.1. With the exception of any breach of confidentiality obligations, neither party will be liable to the other party for any costs, damages, expenditure, loss of profits, prospective profits of any kind or nature etc. arising from the termination or alleged breach of this AGREEMENT or in any manner arising from this AGREEMENT.

ARTICLE 6:- GENERAL TERMS & CONDITIONS

6.1 AGENCY

This agreement between the parties is on a principal to principal basis and it is agreed that XX is not and shall not represent itself as an agent of BECIL.

6.2 CONFIDENTIALITY

The parties along with their employees working on the specified projects agree to maintain strict confidentiality of all information of technical or business nature provided to each other pursuant to this agreement and/ or any subsequent agreement or any correspondence in writing between them. This clause shall survive the expiry/termination of this agreement.

6.3 ASSIGNMENT

This AGREEMENT may not be assigned by either party, by operation of law or otherwise, without the prior written consent of the other party. This AGREEMENT will be binding upon, and ensure to the benefit of, the permitted successors and assigns of each party. Any purported assignment in violation of this clause will be null and void.

7. INTELLECTUAL PROPERTY RIGHTS

BECIL would make no claim on the technology / algorithms used in servicing the clients either during the contract or ever later. Both the parties agree that consideration mentioned under commercial term of this agreement is after taking into consideration the cost of intellectual property rights, if any, to be used under this agreement and no further claim in this regard shall be entertained by BECIL. BECIL shall be kept indemnified by **XX** for any kind of breach of IPR of any third party for all the products/services supplied by it under this agreement.

Any amendment to this AGREEMENT, if required, shall be done in writing with the mutual consent of the parties.

8. WARRANTIES AND UNDERTAKINGS

- i. Each Party acknowledges that it is and shall remain liable to the other party for the consequences of any failure on its part or on the part of its Personnel to fulfill the tasks assigned to it under this Agreement.
- ii. Each Party shall be responsible for providing all appropriate facilities and services as shall be necessary in the proper performance of its obligations, which will be entirely at that Party's own expense.

9. INDEMNITY

Each party shall indemnify, keep indemnified and hold harmless the other Party from and against all costs, expenses, liabilities, injuries, direct, indirect or consequential loss (all three of which terms include, without limitation, pure economic loss, loss of profits, loss of business, depletion of goodwill and like loss), damages, claims, demands, proceedings or legal costs (on a full indemnity basis) and judgments which it may incur or suffer as a result of a breach of this Agreement or negligent acts or omissions or willful misconduct of the Party and/or its Personnel including without limitation any resulting liability the Consortium has to any third party.

10. ASSIGNMENT AND SUB-CONTRACTING

Neither this Agreement nor any of the rights and obligations under it can be assigned by any party. Parties may engage sub-contractors by mutual consent, subject to the compliance with the Tender terms.

11. FORCE MAJEURE

No Party will be deemed to be in breach of this Agreement, nor otherwise liable to the other for any failure or delay in performance of this Agreement if it is due to any event beyond its reasonable control other than strike, lock-out or industrial disputes but including, without limitation, acts of God, war, fire, flood, tempest and national emergencies.

12. DISPUTE RESOLUTION

i. All disputes arising out of or in connection with this Agreement and any amendments thereof, shall, as far as they cannot be amicably settled between the parties, shall be submitted to arbitration by a Sole Arbitrator to be appointed by CMD ,BECIL. The venue of arbitration shall be Delhi. Arbitration proceedings shall be governed by Arbitration & Conciliation Act, 1996 or any subsequent modification thereof.

Note : During a dispute, each Party must continue to perform its obligations under this Agreement.

13. GOVERNING LAW AND JURISDICTION

This Agreement is governed by the laws of India and each Party irrevocably and unconditionally submits to the exclusive jurisdiction of the Courts at New Delhi, India.

14. NOTICES

i. Any intimation, notice, request, grievances, complaint or consent required or permitted to be given or made pursuant to this Agreement shall be in writing. Any such notice, request or consent shall be deemed to have been given or made when delivered in person to an authorized representative of the Party to whom the communication is addressed or when sent by registered post to such Party at the specified address.

ii. Any notice issued pursuant to this Agreement must be in English and in writing. All notices, correspondence or other communication relating to this Agreement shall be given:

- (a) by being personally served on the designated Party; or
- (b) by being sent to the Party's designated address for service by prepaid ordinary mail; or
- (c) to the designated facsimile ; or
- (d) to the designated e-mail address.

The particulars for service to each party are:

Address: XXXX

Fax:

E-mail:

Address: Broadcast Engineering Consultants India Limited

BECIL BHAWAN , C56/A17 Sector 62 Noida 201307

E-mail: wbprasad@becil.com

15. WAIVER

The failure by Parties to enforce at any time or for any period any one or more of the terms or conditions of this Agreement will not be a waiver by them or of the right at any time subsequently to enforce all terms and conditions of this Agreement.

16. SURVIVAL

i. The representations and warranties contained in this Agreement survive the termination of this Agreement.

ii. Each indemnity and guarantee arising in respect of this Agreement survives the performance of obligations arising out of or under this Agreement and the termination of this Agreement and will continue in force as long as necessary to affect their purpose.

17. VARIATION

This Agreement may be amended at any time by written agreement of the Parties. No variation to this Agreement shall be effective unless in writing signed by a duly authorized officer of each of the Parties.

18. COUNTERPARTS

This Agreement is executed in two counterparts, with each party retaining one original.

19. DAMAGES

Once the Bid has been submitted, neither of the parties may withdraw from its obligations & terms of the present AGREEMENT. Any damage/loss caused to BECIL due to failure on the part of XX to enter into a detailed agreement as mentioned above, shall be borne by XX and will be made good by it in case BECIL has to make payment of any damages/penalty to End Customer of any nature whatsoever.

20. ENTIRE AGREEMENT

This Agreement hereto constitutes the entire agreement between the Parties with regard to the subject matter contained in this Agreement and supersedes all prior negotiations, representations, agreements and understandings, written or oral preceding the execution of this Agreement.

By signing this AGREEMENT, BECIL and XX acknowledge that it correctly records the understanding they have reached with regard to the Project.

IN WITNESS WHEREOF, the parties have caused this AGREEMENT to be executed by their respective authorized representatives with effect as of the Effective Date.

NOTE : ALL the RFP Terms and condition and corrigendum thereof , shall be binding on the XX on back to back basis.

FOR AND ON BEHALF OF BECIL

FOR AND ON BEHALF OF XX

Date:

Date:

Place:

Place:

Witness:

Witness

1.

1.

Power of Attorney for signing the Bid on Rs. 100 Stamp Paper

KNOW ALL MEN BY THESE PRESENTS,

We "Name of Bidder" do hereby irrevocably constitute, nominate, appoint and authorize _____, who is presently employed with us and holding the position of " _____", as our true and lawful attorney (*hereinafter referred to as the "Attorney"*) to do in our name and on our behalf, all such acts, deeds and things as are necessary or required in connection with or incidental to submission of our application for qualification and submission of our bid for the Project "**Name of Project**" of " _____" (the "client") including but not limited to signing and submission of all applications, bids and other documents and writings, participate in pre-applications and other conferences and providing information/ responses to the client, representing us in all matters before the client, signing and execution of all contracts including the Agreement and undertakings consequent to acceptance of our bid, and generally dealing with the client in all matters in connection with or relating to or arising out of our bid for the said Project and/ or upon award thereof to us and/or till the entering into of the Agreement with the client. The act done by _____ (Name of authorized person) will be binding on the selected bidder.

IN WITNESS WHEREOF WE, (Name of Bidder)_____, THE ABOVE-NAMED PRINCIPAL HAVE EXECUTED THIS POWER OF ATTORNEY ON THIS DAY OF Date_____ .

For **Name of Bidder**,

Accepted

Witnesses:

1. (Notarized)

PRICE / UNPRICED BID FORMAT/COMPLIANCE STATEMENT

Name of work: **DESIGN, SUPPLY, ERECTION, TESTING AND COMMISSIONING (DSETC) OF 75 M SELF SUPPORTING LATTICE STEEL TOWER INCLUDING PROVISIONS OF MOUNTINGS FOR INSTALLATION OF VHF FM ANTENNA ETC. FOR AKASHVANI FM STATION AT VELLORE, TAMILNADU**

EOI No. **BECIL/GM-1/AIR/75Mtr. Tower /2023-24 Dated: 22-03-2024**

I/We hereby agree to carry out the work as per item rate quote given in the Price Bid format.

UNPRICE BID FORMAT FOR THE WORK IS ATTACHED. ITEM RATES FOR EACH ITEM S ARE TO BE FILLED BY THE BIDDER IN THE PRICE BID FORMAT ONLY, AS PER THE INSTRUCTIONS GIVEN IN THE PRICE BID FORMAT. PRICE BID IS ATTACHED IN THE MS EXCEL SHEET.

UN-PRICE BID FORMAT/ TECHNICAL BID

AIR Tender No. ADG /E/SZ/PUR/NIT-06/SRMST/2023-24

Date: 14.02.2024

Description of work	Design, Supply, Erection, Testing and Commissioning (DSETC) of 75 M Self Supporting Lattice Steel Tower including provision of mounting for installation of VHF FM Antenna etc. for Akashvani FM Station at Vellore Tamilnadu- 1 Job. (As per Akashvani Specification)
Name of the Bidder	
Quotation No. and date	
Complete Postal Address	
BECIL EOI No :	BECIL/GM-1/AIR/75Mtr. Tower /2023-24 Dated: 22-03-2024
E-Mail	

Technical compliance to Technical Parameters, Specification

1	Design, Supply, Erection, Testing and Commissioning (DSETC) of 75 M Self Supporting Lattice Steel Tower including provision of mounting for installation of VHF FM Antenna etc. for Akashvani FM Station at Vellore- 1 Job.				
	S. No. of Akashvani Specification (Section wise & Clause wise) (1)	Details of Akashvani Specification (Part/ Section wise & Clause wise) (2)	Compliance (Yes/No) (3)	The Page No. of the tender offer, where the information / supporting document is available (4)	Remarks (5)
	A	Essential requirement for the tender			
	1.(i)	The tenderer should submit schedule of Requirements/Materials (un-priced)for DSETC in the same format as given in Akashvani Specification in the technical bid, failing which the tender shall be considered incomplete and is liable to be rejected.			
	(ii)	It is also mandatory to mention Make & Model of the offered equipment in the Schedule of Requirements/Materials (un-priced) for supply, failing which the tender shall be considered incomplete and is liable to be rejected.			
	2	Each statement of the technical specification has to be complied with & supported by printed technical literature, technical data sheets, schematic drawings and technical manuals to assess the full merit of the offer, failing which the			

	tender shall be considered incomplete and is liable to be rejected.			
3	The tenderer should submit the tender offer to Akashvani in this format given as Technical bid, section wise & clause wise, in respect of all the sections of technical specifications. The tenderer/ manufacturer of the tower must provide the page number reference of the Technical bid,, in column (4) of the technical bid, clearly indicating the volume number also, if any, for each supporting document to verify the parametric values shown in the technical specifications compliance statement, to assess the full merit of the offer, failing which tender shall be considered incomplete and is liable to be rejected.			
4	The complete technical specification compliance statement (section wise & clause wise)along with schedule of Requirements/Materials (un-priced) as per this format must be signed & stamped on each page by the tenderer/ manufacturer of the tower in the tender document. The tenderer/manufacturer of the tower should mention their name in CAPITAL LETTERS, full address with pin code, phone number, fax number, e-mail address and with their full signature.			
5	The complete tender shall be page numbered.			
6	The Authorization and Guarantee must be given by the tenderer/manufacturer of the tower on their letter head pad duly signed & stamped on each page. The Authorization and Guarantee other than the tenderer/manufacturer of the tower in the tender will not be considered, failing which the tender shall be considered incomplete and is liable to be rejected.			
7	Public Procurement (Preference to Make in India) Order No. P-45021/2/2017-B.E-II dated 15.06.2017 of Government of India, Ministry of Commerce and Industry, Department of Industrial Policy and Promotion shall be applicable.			
8	Any change/modifications in Akashvani technical specifications format, language, technical parameters or of any other nature including the deletion of clause, words, lines in the technical compliance statement by the manufacturer of the tower/tenderer will not be acceptable to Akashvani and the tender is liable to be rejected.			
B	Essential eligibility criteria for tenderer			
I	For Individual Tenderers: Tenderer should meet following Work Experience and Financial capabilities:			
i	Work Experience:			
1.1	Bids should be from Actual Tower Erection firms. Documentary evidence to support Tower erection work like the names, addresses, Telephone Nos, E-Mail addresses, etc of the purchasers for whom towers have been designed , fabricated, supplied and erected must be provided. Copies of supply order and completion certificates issued by such purchaser should be enclosed with the tender. This is an essential requirement.			

	1.2	Tenderer should possess either A or B of the following work experience and meet any one of the three criteria given under C			
	A	<p>A) The Tenderer should have thorough experience in Design, fabrication, Supply, foundation, erection, testing and commissioning of AIR/DD self supporting Lattice Steel tower or RCC cum steel tower with a minimum of 40M Steel portion in past 20 years meeting any one of the following criteria:</p> <p>i) Design, SETC of minimum ONE number of similar type tower of 75 Meters high or above. ii) Design, SETC of minimum TWO numbers of similar type tower of 65 Meters high or above iii) Design, SETC of minimum THREE numbers of similar type tower of 60 Meters high or above.</p>			
	B	<p>The Tenderer should have thorough experience in Design, fabrication, Supply, foundation, erection, testing and commissioning of self-supporting steel lattice tower for other Government/PSU Departments/ Private Broadcaster or communication Firms in the past 7 Years and should have successfully completed these towers meeting any one of the following criteria:</p> <p>i) Design, SETC of minimum ONE number of similar type tower of 75 Meters high or above. ii) Design ,SETC of minimum TWO numbers of similar type tower of 65 Meters high or above iii) Design ,SETC of minimum THREE numbers of similar type tower of 60 Meters high or above.</p>			
	C	<p>And</p> <p>Any one of the following three criteria.</p> <p>i) Three similar DSETC of Tower works each costing not less than the amount equal to 40(forty) percent of the estimated cost of this tender.</p> <p>ii) Two similar DSETC of Tower works each costing not less than the amount equal to 60(sixty) percent of the estimated cost of this tender .</p> <p>iii) One similar DSETC of Tower works each costing not less than the amount equal to 80(Eighty) percent of the estimated cost of this tender, For arriving at cost of similar work being carried out, value of DSETC work executed shall be brought to current costing level by enhancing the actual value of work at simple rate of Ten percent per annum calculated from the date of completion to BID opening.</p>			
	ii	<p>Financial Capabilities: Average Annual turnover of 200% of Estimated cost of the project in the last 03 Financial years OR Cumulative Turnover of 600% of Estimated Cost of the project in last 03 Financial Years during the last 3 years OR</p>			

	Average Annual Net Worth of Minimum of 50% of estimated cost of the project in the last 03 Financial Years OR Cumulative Net Worth of Minimum of 150% of estimated cost of the project in the last 03 Financial Years.			
II	For Joint Ventures:			
	<p>i) JV Members are jointly and severally responsible and liable in the contract. The JV should clearly state the lead partner and other partner.</p> <p>ii) JV should combinedly shall meet the Experience criteria stated under 1.2 of B (Essential eligibility criteria for tenderers) For Individual tenderers.</p> <p>iii) Regarding Financial capabilities Lead partner should have average Financial turnover of at least 15% of the estimated cost of this tender, during the last 3 years ending 31st march of previous Financial year.</p> <p>iv) Regarding Financial capabilities the other partner should have average Financial turnover of at least 7.5% of the estimated cost of this tender, during the last 3 years ending 31st march of previous Financial year</p>			
C	PAYMENT TERMS: Payment will be made as per following sequence in line with the progress of Erection of the Tower as per Section III- Schedule of Requirements/Materials:			
i	For Civil Foundation Work (Item at SI no 2 under WORKS): 90% of total of cost on supply of material and works will be paid after satisfactory competition of Foundation works and submission of duly signed third party inspection certificate and inspection by authorized AIR official. Balance 10 % of the total cost on supply of material and work will be paid after satisfactory completion of SETC and handing over of the tower to AIR.			
ii	Upon Supply of Steel structure material required for construction of Tower from 0 M height to 35M height inclusive of platform at 35M height, payment will be made for 80% of this cost of Material including statutory Taxes. Payment will be made based on submission of duly signed third party inspection certificate and inspection by authorized AIR official and satisfactory receipt of material at site duly supported by the documentary proof. This is applicable for items at SI No 1,2 and 3 under - Supply of Materials at Site.			
iii	Payment will be made for 25 % of the total erection cost including statutory tax upon successful completion of erection of tower upto 35 Mtrs height including platform at 35M height. Payment will be made on third party inspection certificate and inspection by authorized AIR official for satisfactory completion of the stage. This is applicable for items at SI No 3 and 5 under - Works.			
iv	Upon Supply of Steel structure material required for construction of Tower from 35 M height to 50M height inclusive of platform at 50M height, payment will be made for 80% of this cost of Material including statutory Taxes. Payment will be made based on submission of duly signed third party inspection certificate and inspection by authorized AIR official and satisfactory receipt of material at site duly supported by the documentary proof. This is			

	applicable for items at SI No 1,2 and 3 under - Supply of Materials at Site)			
v	10% of total erection cost including statutory tax upon successful completion of erection of tower upto 50 Mtrs height including platform at 50M height will be paid on third party inspection certificate and inspection by authorized AIR official for satisfactory completion of the stage. This is applicable for items at SI No 3 and 5 under - Works.			
vi	Upon Supply of Steel structure material required for construction of Tower from 50 M height to 75M height inclusive of platform at 75M height, payment will be made for 80% of this cost of Material including statutory Taxes. Payment will be made based on submission of duly signed third party inspection certificate and inspection by authorized AIR official and satisfactory receipt of material at site duly supported by the documentary proof. This is applicable for items at SI No 1,2 and 3 under - Supply of Materials at Site			
vii	Payment of 70% of the cost of supply of material for items SI.No.4 to 10 will be made only on completion of erection of tower upto 75M.			
viii	Payment of 80% of charges of installation for items SI.No.4,6 to 14 under work will be made only on completion of erection of tower upto 75 M and satisfactory installation of these items.			
ix	15% of total erection cost including statutory tax upon successful completion of erection of tower upto 75 Mtrs height will be paid on third party inspection certificate and inspection by authorized AIR official. This is applicable for items at SI No 3,4 and 5 under - Works			
x	Rest of the payments and balance payments will be made after satisfactory competition of SETC and handing over of the tower.			
xi	Payment for Insurance premium for tower , if any, will be made as per actuals on submission of respective insurance policy.			
xii	All payments will be made on submission of third party certificate and inspection by authorized AIR official. Arranging third party inspection at various stages of tower as per terms of payment should be at the cost of bidder			
	Section I			
1.0	INTRODUCTION: Akashvani requires Self Supporting Latticed Steel 75 M tower of mean probable design life of 100 years to support FM antenna etc. The tower shall be self-supporting type having square section base out of galvanized steel sections/structures of four legs. Antenna arrangements on tower are indicated in the suggestive drawing Annexure-II Provision for Band II 6 bay antenna aperture for FM service shall be made on the tower. Necessary provisions in the design shall be made for mounting of the VHF Band II 4 array FM antenna in future above the Band II aperture at the top of the tower. The mounting of VHF Band II 6 bay antenna and RF feeder cable is the present requirement. Throughout the entire aperture			

	of band II, the outer to outer width of square cross section should be 650 mm (including splices, nuts & bolts at joints).			
a	The tenderer shall quote for mounting of VHF Band II 6 bay FM antenna systems, feeder cables and related works/services as per details given in the subsequent paragraphs. Mounting of VHF Band II 6 bay antenna system is the present requirement. However, the tower shall be designed to take self-load and wind load for band IIFM antennae 6 & 4 bay, RF feeder cables, and Power Supply cables etc. as per the details of load at Para No. 2.8.			
1.1	SCOPE: These specifications aims at design, fabrication, supply, erection, testing and commissioning of 75 m Self Supporting Lattice Steel tower to support VHF FM antennae as stated above, on turnkey basis. The broad scope of the present tender includes the following as a turnkey job:-			
a	Site visit to inspect the tower site and acquaint himself with the local terrain & site conditions, soil conditions, nature of sub soil, water table and its seasonal variations etc. and make such local enquiries, as may be necessary for any data required by him, before quoting his rates. Otherwise, the tenderer will have to give an undertaking with the tender offer that any variation in the scope of works due to site condition shall be incorporated in the offered bid and Akashvani shall not consider any extra cost on account of that.			
b	Soil testing from NABL approved laboratory.			
c	Preparation and submission of design documents & design drawings of Foundation and Tower structure approved by any IIT/SERC along with certificate from IIT/SERC testifying the soundness and safety of design of foundation and tower structure to Zonal ADG (E) (in hard & soft copies).			
d	Preparation and submission of general arrangement drawing(s) showing all the facilities and requirements as specified in the specification to Zonal ADG (E) (in hard & soft copies).			
e	Preparation and submission of working structural drawings and submitting to Zonal ADG (E) (in hard & soft copies).			
f	Construction of Foundation for tower.			
g	Fabrication, supply, erection, testing and commissioning of tower structure and tower appurtenances/accessories including antenna apertures, internal ladders with free fall prevention system for climbing from ground to top of the tower, platforms with railings, Vertical Cable tray & Horizontal Cable tray as per actual site conditions between transmitter building up to tower, pipe for mounting of FM Side Mount antenna etc			
h	Painting of the tower structure & cable trays.			
i	Providing protection against lightning, earthing of tower, Aviation Obstruction Lights (AOL) including Beacon light and sun-switch. The power supply cable for multi-point power sockets at various platforms, from bottom to the topmost platform of the tower, will also be supplied by the tenderer.			

j	The cables for AOL and utility outlets at various platforms shall be taken on tower on the vertical cable rack.			
k	Hauling up of FM Side Mount antenna [6-Bay VHF FM (Pole type) Antenna]and RF Feeder cable as supplied by Akashvani.			
l	The RF feeder cable and other cables i.e. cables for AOL, power supply etc. between the transmitter building and the tower base shall be routed on a horizontal cable tray supported on G.I. Poles/Angle Iron structure which will be supplied by the tenderer. The cables on the horizontal cable tray shall be provided with G.I. sheet cover of 16 SWG to avoid any damage to RF cable due to any falling objects.			
m	Ground has to be properly leveled after erection of the tower & cleared of all debris etc.			
n	Joint inspection with representative(s) of the firm and Akashvani.			
o	Joint inspection of pending works as pointed out during joint inspection with representative(s) of the firm and Akashvani.			
p	Inspection and certification for structural firmness, verticality and all other design specifications by any IIT/SERCAfter erection of tower and submission of inspection report & certificate(s) (in hard & softcopies) to Zonal ADG (E).			
q	Handing over of tower with completion report (in soft & hard copies)including videography & photographs showingcomplete tower as well as each section of 15M length from base to top,horizontal cable tray and foundation processes starting of excavation, steel layout and reinforcements etc. to leveled finished foundation.			
r	Any other work necessary to complete the DSETC work as a turnkey job.			
1.2	GENERAL:			
a	General terms and conditions of contract for SETC works including all the commercial aspectslike, Packing and Packing List, Insurance and Marine Risk etc., Payment terms, Penalty/Compensation for Delay, Damages and Liabilities, TimePeriod andExtensionfor Delay, Foreclosure of Contract due to Abandonment or Reduction in Scope of Work, Cancellation of Contract in Full or Part, Recovery of Security Deposit, PerformanceGuarantee, Unsatisfactory Workmanship, Damages Incurred During Installation, Indian Electricity Rules, Defects, Recovery of Compensation, Ensuring Payment and Amenities, Compliance with State Labour Laws, Minimum Wages Act Compliance, Indemnifying Government against Patent Rights, Return of Surplus Material, Employment of Technical Staff and Employees, Release of Security Deposit, Safety Code etc. shall be followed by the successful tenderer as defined in the tender document in totality			
b	The tender shall be complete and include all minor items of work and accessories which may not have been specifically defined in this specification and schedule but which are useful and essential for the perfect assembly and completion			

		of the tower. No extra charges will be paid for providing and installing of such items.			
	c	The successful tenderer shall make his own arrangements for power supply, water and the storage of materials and their safe custody at installation site.			
	d	The successful tenderer shall make his own arrangement for employing labour-skilled and unskilled and shall make his own arrangement for providing accommodation for his labour. He should conform to all local, State laws and regulations concerning labour and their employment.			
	e	The successful tenderer shall make good all damage to the purchaser's buildings, property, equipment, article etc. howsoever arising from the construction of the foundation, erection of the tower, and in the course of such work and throughout the period during which the safety of the tower is guaranteed.			
	f	The successful tenderer shall indemnify and hold harmless the purchaser against all claims in respect of damages to buildings, property, articles situated nearby, not belonging to the purchaser, howsoever arising from the construction of the foundation, erection of the tower, and in the course of such work and throughout the period during which the safety of tower is guaranteed.			
	g	The successful tenderer shall indemnify and hold harmless the purchaser against claims in respect of injury/any mishap to any person, howsoever arising from the construction of the foundation, erection of the tower, and in the course of such work and throughout the period during which the safety of the tower is guaranteed.			
	h	The successful tenderer shall fully discharge all obligations under the Indian Workmen's Compensation Act, any local, State laws and regulations in so far as it affects the workmen in his employment.			
	i	The tenderer shall be responsible for safe erection of the tower and other accessories etc. The tenderer shall take all necessary safety measures and precautions during the SETC of the tower. Tower work shall be got done at site under the supervision of qualified representative(s) of the firm.			
	j	The location of the tower at the site vis-à-vis the transmitter building will be marked by Akashvanion Site Lay Out Plan. Maximum area available, including excavation work, for tower will be 20 m × 20 m.			
	1.3	DESIGN, CALCULATION AND DRAWINGS			
	a	The tower shall be designed considering probability factor based on mean probable Design life of tower structure as 100 years.			
	b	The tenderer shall obtain Wind Zones data as per IS: 875 amended to date and for seismic zone data as per IS: 1893 amended to date. The above data only shall be used in the Design Calculations. However, it may be kept in view that the wind map and seismic map are approximate only and require a judicious decision on the part of the designer to provide a good design of the tower for a design life of 100 years			

c	It may also be ensured by the tenderer that if the site falls within a short distance from another wind zone having a higher basic wind speed, the tower shall be designed as per the higher basic wind speed.			
d	The specifications indicated herein are only to guide the tenderer about the requirements of the purchaser. Detailed design of the tower from all aspects shall be got worked out by the tenderer, keeping in view the effects of local meteorological conditions like wind velocity, seismic data, temperature, codal provisions and as per good engineering practice to ensure the safety of the tower.			
e	The design of the tower shall be based on recognized principles of structural design Engineering, conforming to latest IS codes and Standard Engineering Practices. Full responsibility regarding soundness of design including factor of safety and the execution of work rests with the tenderer. For limit state of strength, partial safety factor for loads under worst atmospheric conditions and critical loadings shall be considered as a minimum 1.5 on any destabilizing load (including but not limited to, wind loads). If dead load contributes to the reduction of stresses or supports the stability for any particular action, suitable expected dead loads shall be considered.			
f	The overall force co-efficient for wind load on tower shall be taken from IS: 875 amended to date for Self-Supporting Lattice Steel Towers. For calculating the solidity ratio, actual obstruction area of tower shall be considered. Separate Wind obstructing areas shall be taken for ladder, cable rack and platforms etc.			
g	The permissible stresses in the various structural members of tower shall be adopted from the relevant clauses of IS: 800 amended to date.			
h	Loading effect of seismic forces as per IS: 1893 amended to date and cyclonic winds and conditions of frost etc., if any, is also be taken into consideration.			
i	Loading effect due to antenna and various accessories as given at Para/clause No. 2.8 of Section-II will be taken into consideration.			
j	The R.C.C foundation, tie beams etc, shall be designed and constructed in accordance with IS: 11233 amended to date, IS: 456 amended to date and other application codes. The minimum grade of concrete used shall be M-25.			
1.4	The tenderer must furnish the following documents /information with the tender to assess the full merit of the offer, failing which the tender shall be considered incomplete and is liable to be rejected. This is mandatory requirement.			

a	a. (i)The general arrangement drawing(s) showing all the facilities and requirements as specified in the specification should be attached with the offer. (ii) Outline drawings to scale showing the assembly of the structures. These drawings should show the main dimensions including the size of main structural members, mounting centers, methods of attachment to concrete foundations and any special features of design or form. (iii) Total weight of tower shall be given (Excluding foundation materials).			
b	Detailed information concerning design parameters such as loads due to wind effect&seismic effect, dead loads, antenna loads, combination loads considered, designphilosophy alongwith other informationwhich shall contain the following:(i) Wind speed, terrain category, topographic factor, gust factor, risk factor etc.(ii) Seismic zone factor, importance factor, response reduction factor etc.(iii) Antenna loads due to VHF Band II 6 Bay (PoleType) FM Side Mount antenna, VHF Band II 4 Bay (PoleType) FMantenna at the top of tower. (iv) Load combinations considered.			
c	The design calculations indicating the various formulae used for design, the bearing and shear stresses used for the design of bolted sections and the factors of safety adopted for the various structural components and materials. For limit state of strength, partial safety factor for loads under worst atmospheric conditions and critical loadings shall be considered as a minimum 1.5 on any destabilizing load (including but not limited to, wind loads). If dead load contributes to the reduction of stresses or supports the stability for any particular action, suitable expected dead loads shall be considered.			
d	Typical design load calculation with methodology due to seismic effect.			
e	Details of Bill of Materials (BOM) showing Grade Designation and Quality of steel members, weight of the tower structure, details of fasteners, nuts, washers etc. & steel used in foundation.			
f	Design forces compression/tension due to critical load combination, design of main members panel wise i.e. leg, bracing (diagonal & horizontal) with section adopted,capacityof members based on length, slenderness ratio, allowable stress with reference& formula.			
g	Deflection at top of tower and reaction at base in most critical load combinations.			
h	The detailed design of foundationsfor 8.2 MT/Sq. M SBC.			
i	i. Complete printed technical literature/technical data sheet/schematic drawings/detailed information of LED based Aviation Obstruction Light and details of Antenna Fixtures, Pipes, Power Supply cables, paint materials, earthing etc.			
j	Detail of activity wise Bar/PERT chart with delivery schedule.			

k	The complete technical specifications (Section wise & Clause wise) compliance statement along with Schedule of Requirements/Materials (un-priced) duly signed & stamped on each page by the tenderer/tower manufacturer as per the format given above in clause A (3) of Essential Requirement for the Tender.			
l	Details of past experience. Refer clause B. Essential eligibility criteria for tenderer			
1.5	<p>The successful tenderer shall furnish the following documents/information within two months after issue of acceptance of tender:</p> <p>(i) Soil testing with detailed report & document(s) (in hard & soft copies) -2 Sets</p> <p>(ii) Submission of general arrangement drawing(s) showing all the facilities and requirements as specified in the specification to Zonal ADG (E). (in hard & soft copies) -2 Sets</p> <p>(iii) Submission of design documents & design drawings of Foundation and Tower structure approved by any IIT/SERC along with certificate from IIT/SERC testifying the soundness and safety of design of foundation and tower structure to Zonal ADG (E). (in hard & soft copies) -2 Sets</p> <p>(iv) Detailed working structural drawings (in hard & soft copies) -2 Sets</p> <p>(v) Any other drawings for the completeness of the tower design as per Akashvani specification.</p> <p>The following references shall be indicated in the above design documents & design drawings, working structural drawings, general arrangement drawings etc. while submitting to concerned Zonal Offices.</p> <p>(1) Akashvani AT No. (2) Akashvani Specification No. & (3) Approval of competent authority with signature & stamp.</p> <p>After the acceptance of all working structural drawings by Zonal ADG (E), the successful tenderer shall send all working structural drawings to concerned Zonal ADG (E), concerned Akashvani Station(s) and Akashvani Directorate indicating all the references. All these working structural drawings as per Akashvani specifications must be available with all concerned offices before the start of the tower work at the site</p>			
1.6	PATENTS AND COPYRIGHTS: The tenderer shall hold the purchaser and his employees safe, harmless and immune from any liability that may arise out of infringements of patents and copyrights associated with the design, fabrication, erection and use of the tower and its accessories.			
1.7	DELIVERY PERIOD: The Delivery Period for completion of works as per specification shall be 100 days.			
1.8	INSPECTION & TESTS:			
a	<p>Inspection will be done at various stages as follows: -</p> <p>1. Design verification and checking of drawings before commencement of construction/fabrication.</p> <p>2. Inspection of soil excavation at foundation stage.</p> <p>3. Material inspection before shifting at site. (This includes reports/certificates of different quality test from BIS /NABL</p>			

	approved lab(s) as mentioned below. 4. Inspection during excavation for foundation and after erection of tower. 5. Checking of Verticality tolerance etc. as per Akashvani specifications at the final stage i.e. after complete erection of tower.			
b	Test for strength of foundation: The concrete used in the foundation should be designed as per IS:10262 amended to date. Along with the foundation, cubes should be cast, which can be tested on 7 days and 28 days to get the strength of the concrete used in the tower foundation. Reinforcement used in the foundation must also be tested in a BIS/NABL approved Labs.			
c	Pre-dispatch inspection of tower material shall have to be got done by representative(s) of Akashvani in India by giving an advance notice of TWO WEEKS. The certifying agency IIT/SERC that will issue certification for structural safety & firmness, verticality and all other design specifications in compliance of clause 1.9 of Section-I will also be part of PDI. Pre-dispatch inspection of tower material and subsequent inspection of erected tower shall be done as per mutually accepted test procedure, which shall be submitted and got approved from Akashvani before the supply of tower material. A draft Acceptance Test Protocol as per Annexure-I is enclosed for guidance purpose. Travelling expenses for Akashvani's representative(s) will be borne by Akashvani.			
d	Structural Steel: The tenderer shall procure all structural steel members from namely SAIL, TISCO, JINDAL and RINL. Structural steel sections not available from main producers can be procured from secondary producers subject to production of proof of manufacture of structural steel members from virgin billets produced from primary steel producers before starting fabrication work. Original copies of the test certificates of steel should be made available at the time of inspection. Samples may be taken at the discretion of Akashvani and tested at BIS /NABL approved lab(s) as per provisions in this regard in the relevant IS codes, for which cost shall be borne by the tenderer. In case the test results indicate that the Steel arranged by the tenderer does not conform to relevant IS Codes, the same shall be rejected.			
e	Fasteners: i. Manufacturer's routine test certificates for bolts, nuts, washers etc. as laid down in relevant BIS code shall be submitted by the tenderer at the time of inspection. Samples may be taken at the discretion of Akashvani and tested at BIS /NABL approved lab(s) as per provisions in this regard in the relevant BIS codes, for which cost shall be borne by the tenderer. In case, the test results indicate that the Fasteners arranged by the tenderer does not conform to relevant BIS Codes, the same shall be rejected.			
f	Galvanizing: The tenderer shall prepare a detailed galvanizing procedure			

	including Flow Chart with control parameters and all plant standards as required above and submit to Akashvanias part of Quality Assurance Plan.			
g	All standard tests, including quality control tests, in accordance with appropriate BIS standard shall be carried out unless otherwise specified herein.			
h	<p>The following test certificates should be made available at the time of inspection. All the test certificates shall be issued by BIS /NABL approved lab(s).</p> <ol style="list-style-type: none"> 1. History of metallurgy and Original copies of the test certificates of steel as per the format prescribed by BIS Code. 2. Manufacturer's routine test certificates for bolts, nuts, washers etc. as laid down in relevant BIS code. 3. All standard tests, including quality control tests, in accordance with appropriate BIS standard regarding galvanizing. 4. All standard tests for welds as per BIS. 			
i	<p>In addition to the provisions of clause regarding inspection, following shall also be included:</p> <ol style="list-style-type: none"> 1. The tenderer shall keep Akashvani informed in advance about the time of starting and progress of manufacture and fabrication of various parts, so that it can be inspected, if required. 2. The acceptance of any part or items shall in no way relieve the tenderer of any part of his responsibility for meeting the overall requirement of the specifications. 3. Any member of the structure found not to comply with the approved drawings, shall be rejected. No member once rejected should be resubmitted for inspection except in case, where Inspecting Officer considers that the defect can be rectified. 4. All welded structures shall be subject to a non-destructive testing as per BIS code requirement and cost should be borne by the tenderer. 5. IS: 822 amended to date to be followed for inspection of welds and IS: 3600 (Part 1 to 9) amended to date to be followed for testing of welds. 6. All gauges, templates, jigs, fixtures, instruments necessary for inspection and testing shall be provided by the tenderer to Akashvanifor the purpose of inspection. 7. To ensure effective in-process quality control, it is essential that the manufacturer arrange all the testing facilitates for tests like, weight of zinc coating, tensile & shear strength, non-destructive testing of welds etc. The manufacturer should have proper quality assurance system in line with requirement of this specification. 8. Each Piece of steel work shall be distinctly marked before delivery in accordance with marking diagram and shall bear such and other marks as well to facilitate erection. 9. Each individual tower member shall carry a stamped mark (number) assigned to in the approved drawings. These stamping shall be done by a metal die of 16 mm size before galvanizing and on optimum depth so as to be clearly legible after galvanizing. 			

1.9	CERTIFICATION & COMPLETION REPORT AFTER ERECTION OF TOWER:			
a	After erection of tower, the tower structure shall be inspected and certified for its structural safety & firmness, verticality and all other design specifications by any IIT/SERC. Certified inspection report with all the observations, recommendations etc. shall be submitted to Akashvani. The recommendations/suggestions will have to be incorporated by the tenderer before submitting the final completion report. All costs on this inspection and post inspection corrections, if required, for completeness of the tower shall be borne by the tenderer. The concerned IIT/SERC should be made part of PDI in order to facilitate above certification.			
b	The tenderer is also required to submit completion report colour printed and duly bound for the reference and record of Akashvani. A soft copy of the above must also be submitted.			
1.10	GUARANTEE:			
1	The tenderer shall guarantee the stability, safety, durability and satisfactory mechanical behavior of the structure under specified conditions of operation, wind pressure and loading, for a period of FIVE years from the date of the taking over of the tower.			
2	In the event of structural failure or any component/part of the structure within the guarantee period specified above, the tenderer shall undertake to replace the components/parts which have failed and those which were damaged as a result thereof, free of cost and bear the expenditure to be incurred for re-erection of the tower.			
3	All the Electrical/Electronic parts/materials such as AOL, Control Panels, cabling/wiring etc. shall be guaranteed for FIVE years from the date of handing over.			
	Section-II			
2.0	TECHNICAL SPECIFICATIONS: All the BIS Specifications referred herein after shall be read with the latest amendments i.e. up to the date of submission of tender offer.			
2.1	FABRICATION AND DESIGN:			
2.1.1	Tower steel section:			
i	All tower members shall be made out of structural steel conforming to IS:2062 amended to date.			
ii	The main members in legs, bracings, horizontals etc, shall not be less than 6mm thick.			
iii	The secondary members, like hand-rails, ladders, redundant etc. shall not be less than 5mm thick.			
iv	In case certain steel sections are not available in the market in the designed thickness, the next higher thickness available should be used.			
2.1.2	Fasteners (Bolts, nuts and washers):			
i	The tower members and other structures shall be connected/assembled by means of bolts and nuts with spring washers or locking nut.			

ii	The quality of bolts should conform to mechanical properties as per IS:1367 amended to date and dimension to IS:6639 amended to date.																			
iii	The bolts shall be of minimum property class 8.8 as specified in IS:1367 (Part-3) amended to date.																			
iv	Nuts shall conform to IS:1363(Part-3) and appropriate property class as specified in IS:1367(Part-6) amended to date. Nuts should be double chamfered as per the requirement of IS:1363 amended to date.																			
v	The shear, bearing & tensile strength shall be in accordance with IS:800 amended to date. The fasteners shall be procured from reputed manufacturers such as UNBRAKO, TVS SUNDRAM, NEXO, BKR etc.																			
vi	(vi) All the bolts and nuts shall be galvanized by high temperature hot-dip galvanizing in accordance with IS:1367(Part-13) amended to date.																			
vii	The bolts shall be as per IS:12427 & IS:4000 amended to date.																			
viii	The plain and spring washers shall be hot-dip galvanized as per IS:1367 (Part-13) amended to date OR electro galvanized as per IS:1573 amended to date & IS:3655 amended to date, as applicable.																			
ix	<p>Nut Rotation From Snug Tight Condition:</p> <table border="1"> <thead> <tr> <th>Bolt length (as measured from underside of head to extreme end of point)</th> <th>A bolt faces normal to bolt axis</th> <th>One face normal to bolt axis & other face sloped not more than 1:20 (bevel washer not used)</th> <th>Bolt faces slope not more than 1:20 from normal to bolt axis (bevel washers not used).</th> </tr> </thead> <tbody> <tr> <td>Upto including 4 dia.</td> <td>1/3 turn</td> <td>1/2 turn</td> <td>2/3 turn</td> </tr> <tr> <td>Over 4 dia. but not exceeding 8 dia.</td> <td>1/2 turn</td> <td>2/3 turn</td> <td>5/6 turn</td> </tr> <tr> <td>Over 8 dia. but not exceeding 12 dia.</td> <td>2/3 turn</td> <td>5/6 turn</td> <td>1 turn</td> </tr> </tbody> </table>	Bolt length (as measured from underside of head to extreme end of point)	A bolt faces normal to bolt axis	One face normal to bolt axis & other face sloped not more than 1:20 (bevel washer not used)	Bolt faces slope not more than 1:20 from normal to bolt axis (bevel washers not used).	Upto including 4 dia.	1/3 turn	1/2 turn	2/3 turn	Over 4 dia. but not exceeding 8 dia.	1/2 turn	2/3 turn	5/6 turn	Over 8 dia. but not exceeding 12 dia.	2/3 turn	5/6 turn	1 turn			
Bolt length (as measured from underside of head to extreme end of point)	A bolt faces normal to bolt axis	One face normal to bolt axis & other face sloped not more than 1:20 (bevel washer not used)	Bolt faces slope not more than 1:20 from normal to bolt axis (bevel washers not used).																	
Upto including 4 dia.	1/3 turn	1/2 turn	2/3 turn																	
Over 4 dia. but not exceeding 8 dia.	1/2 turn	2/3 turn	5/6 turn																	
Over 8 dia. but not exceeding 12 dia.	2/3 turn	5/6 turn	1 turn																	
	Alternatively nuts may be tightened using a calibrated wrench so that the proof load of the bolt specified in IS: 1367 amended to date is achieved. "Snug tight is defined as the tightness attained by a few impacts of an impact wrench or the full effort of a man using an ordinary spud wrench. Following this initial operation, bolts shall be placed in remaining holes in the connection and brought to snug tight position".																			
2.1.3	Fabrication:																			
i	The fabrication of tower components shall conform to IS:800 amended to date.																			
ii	All steel sections shall be fabricated as per the approved drawings																			
iii	Gas cutting, shearing, sawing, modification of holes, welding etc. is not permitted for finished members at the site.																			
2.1.4	Drilling and punching:																			

	i	Holes for bolts shall be drilled or punched with jig, but drilled holes shall be preferred. Punching may be adopted for thickness up to 5 mm. Tolerances regarding punched holes are as follows.			
	a	Holes must be perfectly circular and no tolerance in this respect will be permissible.			
	b	The maximum allowable difference in diameter of the holes on the two sides of plates or angles shall be 0.8 mm i.e., the allowable tolerance in punched holes should not exceed 0.8 mm on diameter.			
	ii	Drilled & punched holes must be square with the plates or angles and have their wall parallel.			
	iii	Holes on both side of the bend line in a bent member shall be drilled after bending.			
	iv	The mild steel section up to 75×75×6 may be bent by cold process up to bend angle 10° and all other angle sections and bend angles shall be bent by hot process.			
	v	The formation of bends by the “Cut & Weld” method unless specified in drawings is not permitted without prior approval of Akashvani.			
	vi	No angle member shall have two leg flanges brought together by closing the angle.			
	2.1.5	Welding:			
	i	Welding, if any, shall be carried out in accordance with IS:816, IS: 2879, IS:1024 and IS:9595 amended to date as appropriate			
	ii	Butt welding shall be carried out either by submerged arc or shielded arc welding.			
	iii	Pre-heating and post heating shall be employed as may be necessary for welding members			
	iv	For welding of any particular type of joint, welder shall give evidence, acceptable to Akashvani of having satisfactorily completed appropriate tests as described in relevant BIS codes.			
	2.1.6	Tolerance: Fabrication tolerances shall not exceed those specified in IS:7215 amended to date as applicable to group B structures			
	2.1.7	Galvanizing:			
	i	All steel tower members shall be hot dip galvanized after fabrication is completed. The galvanizing of the tower members shall conform to IS:2629 amended to date, IS:4759 amended to date & IS:4736 amended to date.			
	ii	The thickness of hot dip galvanizing shall be generally 120 microns (equivalent to 860g/m ² of Zinc (Coating) in accordance with IS:4759 amended to date.			

iii	The bidder shall arrange for procurement of Zinc required for galvanizing the structure. The Zinc required for galvanizing shall conform to IS: 209 amended to date or IS:13229 amended to date. All galvanized members shall withstand test as per IS:2633 amended to date.			
iv	All the bolts and nuts shall be galvanized by high temperature hot-dip galvanizing in accordance with IS:1367(Part-13) amended to date.			
v	The plain and heavy washers and spring washers shall be hot-dip galvanized as per IS:1367 (Part-13) amended to date OR electro galvanized as per IS:1573 amended to date, IS:3655 amended to date & IS: 3203 amended to date, as applicable.			
2.1.8	All the steps shall be taken by tenderer /manufacturer as per IS:9172 amended to date to prevent corrosion			
2.2	FOUNDATION:			
i	The tenderer is advised to inspect the tower site and acquaint himself with the local terrain & site conditions, soil conditions, nature of sub soil, water table and its seasonal variations, area contours etc. and to make such local enquiries, as may be necessary for any data required by him, before quoting his rates for foundation of the tower.			
ii	The R.C.C foundation, tie beams etc, shall be designed and constructed in accordance with IS:11233 amended to date, IS:456 amended to date and other application codes. The minimum grade of concrete used shall be M-25.			
iii	For the purpose of this bid, the tenderer shall quote the rates (in the commercial bid) on the basis of 8.2 MT/ Sq. M Soil Bearing Capacity (SBC) at 3 m depth. The tenderer shall also quote for "Extra for reduced Soil Bearing Capacity (SBC) below 8.2 MT /Sq. M for every 0.55 MT/Sq. M decrease."			
iv	The successful tenderer shall carry out soil tests through NABL approved Laboratory. When a test boring is conducted, all safety requirements are to be taken/ adhered from human safety aspect. Complete test observations will have to be recorded and furnished to Akashvani After taking samples, the bored hole should be closed properly.			
v	The cement, sand and aggregate used shall be of best grade and shall be mixed in a mechanical mixer as per the design. The foundation shall be watered and cured for at least 14 days and the erection of the tower shall be commenced only after the foundations are thoroughly cured. Measurements of levels of all tower footings will be taken in the presence of Akashvani representative.			
vi	Foundation is to be protected by provision of pitching work on sloping terrain to protect the foundation from erosion.			
vii	In case of rock anchorage type foundation, workmanship & other requirements shall be in accordance with IS: 10270 amended to date.			
viii	Anchorage bolts to concrete pedestal from tower is to be checked with the clauses mentioned in ACI:318-14 Chapter 17.			

2.3	VERTICALITY TOLERANCES, DEFLECTION, TWIST& SWAY:			
2.3.1	UNDER STILL AIR CONDITIONS: The tower shall be vertical after erection and no straining shall be permitted to achieve this. The verticality of tower shall be within the provisions of Table-1(III) (b) of IS: 12843:1989 amended to date, viz. $\pm H/1500$ or ± 25 mm (whichever is less) for towers over 30 M height i.e. the bottom of the line joining to the centre of the top of the tower and the centre of the base of the tower shall be within this limit. (H refers to the height of the tower).			
2.3.2	2.3.2. UNDER MAXIMUM WIND LOAD CONDITIONS:			
i	The horizontal deflection of the vertical axis of tower shall not be more than 1° (degree) at various levels including top, under maximum wind and other critical loading conditions. A sketch showing deflection of the vertical axis of tower as per Annexure-IV is enclosed for reference only. The deflection at top of tower shall be checked as per the provision made in latest IS:800: 2007. The reaction at base shall be unfactored.			
ii	The angular twist shall not exceed 0.5 degree refer Annexure-V.			
2.4	PROTECTION AGAINST LIGHTNING: The tower shall be provided with a suitably designed complete system of lightning protection in accordance with provision of IS:2309 (amended to date) including necessary earthing based on the specific resistivity of the soil and sub-soil water level. The lightning protection system shall be got approved from Akashvani, before execution. Copper strip of size 50 mm × 2 mm is to be provided for Lightning Arrester from top of the tower to the ground along with separate earthing (2 Nos. earthing).			
2.5	2.5. PAINTING : The details regarding painting of tower are given below:-			
a	For Coastal Area			
i	The tower shall be given one coat of ETCH primer (2 Pack) followed by two coats of Epoxy Red Oxide Zinc Phosphate Weldable primer(Two component) and two or more coats of Polyurethane Full Gloss Enamel(Two Pack) paint after erection. The tower shall be painted to have equal alternate bands of international orange and white colours with top and bottom bands painted in orange as per latest International Civil Aviation Organization Recommendations.			
ii	The paints used in painting shall be in accordance with IS: 13213 amended to date.			
iii	Etch primer shall conform to IS: 5666 amended to date and Epoxy Red Oxide Zinc Phosphate Weldable primer (Two components) shall conform to IS: 14506 amended to date.			
iv	Painting shall be done in accordance with IS: 1477 Part I & II amended to date.			

v	The minimum dry film thickness shall be 8 microns of ETCH primer, 25 microns of each coat of Epoxy Red Oxide Zinc Phosphate Weldable primer(Two component) and 35 microns of each coat of Polyurethane Full Gloss Enamel(Two Pack) paint. The overall Dry Film Thickness (DFT) should not be less than 128 microns.			
2.6	EARTHING: All the four tower legs shall be earthed individually, following the standard practice of earthing of such structures in level ground and mountainous regions (Details shall be attached with the tender). The earth resistance of the tower earthing shall be less than 1 ohm. A suggestive drawing No. TM-16597 for earthing is enclosed.			
2.7	FACILITIES ON TOWER: The following facilities are required to be provided on tower:			
2.7.1	PLATFORM:			
	Provision of platform for access to the antenna and cables at different levels to be made as indicated in Annexure-II. 1.5 meter high handrails would be provided at each level with expanded metal net for additional safety. Platform flooring will consist of chequered plate conforming to IS:3502 amended to date and shall be designed as to take stationary and moving load of 4 persons plus equipment (weighing about 100 Kg.). At each platform "Toe-plates"(6") as a form of protection against accidental dislodging of small tools, are to be provided.			
2.7.2	LADDERS:			
i	An internal ladder of width not less than 450 mm starting from ground level of the tower and going up to the top with openings at all the platforms shall be provided. The ladder shall be foldable/ retractable at the ground level and length of foldable/retractable portion of ladder should not be more than 1.5M. The ladder shall be hooped type with FREE FALL PREVENTION SYSTEM for safety of the climbing personnel. The face on which the ladder is to be provided shall be intimated by Akashvan before the commencement of erection of tower. The free fall prevention system shall conform to EN -353-1 amended to date (Vertex PN 700). The wire shall be steel grade 316. The shock absorber shall be installed to reduce the impact if fall on victim as well as the structure. The intermediate shall be provided at every 10 m to reduce the vibration due to wind.			
ii	Rungs of the ladder shall be clear of any obstructions to the climber and equally spaced by not more than 300 mm.			
2.7.3	AVIATION OBSTRUCTION LIGHTS & POWER SUPPLY CABLES:			

a	LED based Aviation Obstruction Lights including beacon light (with twin aviation obstruction light arrangement in 'ON' duty and 'STANDBY' mode with alarm monitoring) should be provided. The globes and their housings shall be strong, weather proof and of approved manufacturer. There shall be 2 lights located diagonally at each level, except the top level. The aviation obstruction lighting arrangement shall be as per latest International Civil Aviation Organization Recommendations.			
b	Power supply load of the aviation lights shall be evenly distributed on all the three phases, in order to ensure that with failure of the single phase all the lamps at each level do not go off. The power supply cable for the lights shall conform to IS: 1554 amended to date or the power supply cables for the aviation lights shall be liberally rated and shall conform to the latest Indian Standard specifications.			
c	One No., 3 Core, 6 Sq. mm copper conductor (Stranded), XLPE insulated, sheathed, weatherproof, armoured Power Supply cable for Multipoint power sockets on each platform shall be supplied and laid & clamped to the cable rack. This cable shall be terminated in SP&N MCB of suitable rating in a suitable weather proof metal box at the tower base including the earthing etc. Power sockets with switches of suitable rating shall be provided and suitably mounted at each platform in weatherproof boxes.			
d	Two Nos. 4 core, suitably rated, copper conductor, XLPE insulated, sheathed, weather proof, armoured power supply cable for AOL shall be provided and laid on vertical Cable Tray and fixed with cable clamps. This cable shall be terminated in TP&N MCB of suitable rating in a suitable weatherproof metal box at the tower base including the earthing etc.			
e	Distribution of supply to Aviation Obstruction Lights shall be through suitable weatherproof junction boxes with suitable mounting.			
f	The successful tenderer shall provide temporary Aviation Obstruction Lights during erection of tower as soon as the tower reaches the height of 25 meters or such heights as prescribed in latest International Civil Aviation Organization Recommendations			
g	A "Sun Switch" is required to be provided for AOL so that these are "ON" automatically, if sufficient sunlight is not available around tower. In no case, Sun Switch is to be installed inside a room or covered space.			
h	The details of Power Supply arrangements for aviation obstruction lights shall be provided with the tender.			
i	The LED based AOL offered shall be approved by National Physical laboratory (NPL) / ERTL / and test report for the same must be submitted with the offer as well as with the material.			
j	The detailed circuit diagram of the AOL, No. of LEDs used, details of configuration of LEDs (series parallel arrangement etc.) should be submitted with the offer.			
2.7.4	CABLE RUN-WAY AND ANTENNA SUPPORTING FIXTURES:			

a	<p>Vertical Cable Rack/Tray: The vertical cable rack for laying cables as indicated in Para 2.8.2 starting from the base to the top of the tower shall be provided. This cable rack shall be routed along the tower face or leg and should be just behind the climbing ladder or be a part of this for easy accessibility. The cable rack shall carry all the RF feeder cables, AOL & Service cables etc. It should have provisions for fixing the cable clamps. Vertical cable tray shall be provided as per drawing No. TM-16640. Vertical cable tray is to be painted in accordance with Para 2.5 above.</p>			
b	<p>Side Mounted FM Antenna Fixtures: Provision for fixing 100 mm inner dia. supporting seamless GI pipe category Class "C" of 20M length for FM Side Mount (Pole type) Antenna-6 Bay as per drawing No. TM-16599 shall be made on three faces of the tower. This supporting pole will be fixed in FM Side Mount antenna aperture on one of the three faces, to be intimated at the time of erection of tower. The fixtures of the antenna shall not foul with the cable routing from the power divider to the antenna. The above pipe shall be supplied by the tenderer as part of tower.</p>			
c	<p>Top Mounted second channel FM Antenna Fixtures: Provision is to be made for fixing 200 mm inner dia. seamless GI pipe category Class "C" of 12 M length as per suggestive drawing Annexure-II for supporting top mount VHF FM Pole Type Antenna for second channel in future.</p>			
d	<p>Horizontal Cable Rack/Tray: The cable run between the tower base & transmitter building shall be through a horizontal cable tray to be provided by the tenderer. The rack will be supported on 75 mm inner dia. category Class "C" G.I. pipes or 60x60x5mm G.I. angle iron structures & the rack will be covered by Semi Circular or suitable design 16 SWG G.I. sheet cover. The tenderer must quote for the horizontal cable rack on the basis of per meter rates. The pricing for horizontal cable rack should include the laying charges of all cables on this tray. Horizontal cable tray shall be provided as per drawing No. TM-14453/3 and shall be connected to vertical cable tray with intersection. Pipes or angle frames should be grouted with RCC in ground as per practice and have a height of 4 Meters from the ground. Horizontal cable tray is to be painted in accordance with Para 2.5 above</p>			
2.8	<p>2.8. TOWER LOADING DETAILS DUE TO FM ANTENNA, MICROWAVE DISH, MOBILE ANTENNA, RF CABLES ETC. ARE GIVEN BELOW:</p>			
2.8.1	<p>2.8.1. The tower shall be designed to take self-load and wind load as per details of load given below. Ice loading shall also be taken into consideration as per site requirement, if required. These are in addition to self-loading of tower.</p>			

S. No.	Description	Net weight (Kg)	Wind load (Kg)	Remarks															
1.	VHF Band II FM Side Mount antenna- 6Bay (Pole Type)	600	900 @ 198 Km/hr. without ice	Weight & wind loading due to support column & mounting accessories not included.															
2.	VHF Band IIFM Side Mount antenna 4 Bay (Pole Type) (Provision for Future)	450	900 @ 198 Km/hr. without ice	Weight & wind loading due to support column & mounting accessories not included.															
2.8.2	2.8.2. The following cables are to be installed on tower. Wind loading due to these may also be taken into consideration.																		
	<table border="1"> <thead> <tr> <th>S. No.</th> <th>Description of items with weight in Kg.</th> <th>Qty.</th> </tr> </thead> <tbody> <tr> <td>1.</td> <td>4" RF cable for FM antennas (Approx 3.50 kg/m)</td> <td>2Nos.</td> </tr> <tr> <td>2</td> <td>1 ⁵/₈ " RF cable for FM antennas (Approx 1.50 kg/m) (Provision for Future)</td> <td>2Nos.</td> </tr> <tr> <td>4.</td> <td>3 Core, 6 Sq. mm Power Supply cable*</td> <td>1 No.</td> </tr> <tr> <td>5.</td> <td>Solid State Aviation Obstruction Light cable* etc. (with twin circuit arrangement)</td> <td>2Nos.</td> </tr> </tbody> </table>				S. No.	Description of items with weight in Kg.	Qty.	1.	4" RF cable for FM antennas (Approx 3.50 kg/m)	2Nos.	2	1 ⁵ / ₈ " RF cable for FM antennas (Approx 1.50 kg/m) (Provision for Future)	2Nos.	4.	3 Core, 6 Sq. mm Power Supply cable*	1 No.	5.	Solid State Aviation Obstruction Light cable* etc. (with twin circuit arrangement)	2Nos.
S. No.	Description of items with weight in Kg.	Qty.																	
1.	4" RF cable for FM antennas (Approx 3.50 kg/m)	2Nos.																	
2	1 ⁵ / ₈ " RF cable for FM antennas (Approx 1.50 kg/m) (Provision for Future)	2Nos.																	
4.	3 Core, 6 Sq. mm Power Supply cable*	1 No.																	
5.	Solid State Aviation Obstruction Light cable* etc. (with twin circuit arrangement)	2Nos.																	
	(* Items are to be supplied by tenderer including lugs, connectors etc.)																		
2.8.3	The weight & wind loading due to mounting accessories of FM Side Mount antenna(6-Bay) and 100 mm inner dia. seamless G.I. pipe category "C" of 20M length is required to be taken into consideration for loading by the tenderer as per design.																		
2.9	WORKMANSHIP:																		
a	All workmanship for foundation work shall be in accordance with specifications, approved drawings and IS: 456 amended to date.																		
b	The tenderer shall carryout excavation in all kind of soils. While excavating, excavation shall be adequately supported or formed to ensure stability of the sides and prevents any damage to the surrounding ground or structures.																		
c	Excavation material suitable for re-use as backfill shall be stored within the site working area.																		
d	For excavation in cohesive soil the final 150mm above foundation bottom level shall only be removed immediately prior to placing to M10 concrete pad.																		
e	The tenderer shall not permit water accumulation in excavated pit.																		
f	The tenderer shall carry out concrete trial mix using representative materials.Mix proportioning shall be carried out under full scale condition as per IS: 10262 amended to date. The testing shall be carried out in accordance with IS:																		

		456 amended to date. Minimum three test cubes shall be tested.			
	g	The aggregate and cement shall be proportioned by means of efficient weigh batching machines. The machine shall be maintained & cleaned periodically.			
	h	The concrete shall be mixed in batches, in concrete mixing machines, which shall comply to IS Codes. Manual or hand mixing is not permitted.			
	i	The tenderer shall carry out slump or other workability tests as required during concreting of work, in order to relate the degree of workability of the mix to the values obtained during the trial mix.			
	j	All frameworks shall be accurately constructed to produce the correct foundation shape and shall be sufficiently strong to withstand pressure arising from concrete during placement and compaction.			
	k	Reinforcement bar shall be bent and fixed in accordance with procedure specified in IS: 2502 amended to date. The high strength deformed steel bars should not be re-bent, straightened. All the reinforcement should be placed and maintained in the position as shown in the drawing by providing proper block, spacers and supporting bar			
	l	The concrete shall be placed in layer maintaining proper cover of reinforcement, which shall be compacted by vibrators.			
	m	The curing & protection shall be as per BIS standards, after compaction of the concrete and shall ensure adequate protection.			
	n	Backfilling shall be compacted in 300 mm layers to achieve a bulk density of not less than 1.7 MT/m ³ .			
	o	The tenderer shall clear the site from all surplus soil and other materials before handing over the tower to Akashvani.			
	p	Inspection and testing of concrete work shall be in accordance to provisions of IS: 456 amended to date.			
	q	In case of rock anchorage type foundation, workmanship & other requirements shall be in accordance with IS:10270 amended to date.			
	r	Testing of concrete quality is to be performed as per methods stated in IS: 516 -1959 (Reaffirmed 2004).			
	s	If it is required to check the concrete strength in-site IS:1331(Part I & II, Reaffirmed 2004) method of test is to be performed.			
	2.10	Marking of Members Each individual tower member shall carry a stamped mark (number) assigned to in the approved drawings. These stamping shall be done by a metal die of 16 mm size before galvanizing and on optimum depth so as to clearly legible after galvanizing. A plate indicating the name of the tower, Specification No., AT No., Manufacturer's identity and year of manufacture shall be supplied by the tenderer for display at the bottom of the tower.			
	2.11	Packing: The material shall be boxed or bundled for transport in the following manner:			

a	Angle shall be packed in bundles securely wrapped four times around at each end and over 900 mm with No. 9 SWG gauge wire with ends twisted tightly. Gross weight of any bundle shall not exceed 450 Kg.			
b	Angles, brackets, plates and similar small loose pieces shall be tested and bolted together in multiples, and securely wired together through holes wrapped round at least four times with No. 9 SWG steel wire and ends twisted tightly. Gross weight of each bundle shall not exceed 70 Kg.			
c	The correct numbers of bolts, nuts and washers plus extra bolts, nuts and washers for the tower shall constitute a packing unit and shall be dispatched packed in crates or wooden boxes strong enough to withstand the normal vigorous transit and handling. The various sizes of bolts, nuts and washers shall be kept in separate bags inside the main container. Each container shall carry a list of the bolts contained therein printed in water-proof ink, resistant to moisture. Weight of the container shall not exceed 70 Kg.			
2.12	Marking of Packages Each bundle or package shall have the following details marked on it.			
a	The name and address of the Consignee			
b	The relevant marks and number of tower members or reference of bolts, nuts and small components like gusset plates, various attachments etc. for easy identification.			
c	The marking shall be stenciled in indelible ink on the top member of the bundle of tower steel and on wooden boxes or gunny bags containing smaller components.			
d	Akashvani shall, in no case, be responsible for loss of any package or bundle during transit. It shall be the responsibility of the bidder to replace the lost items free of cost.			
2.13	Additional items of works			
	Mounting of Antenna system: After the erection of the tower, the tenderer shall also mount FM Side Mount antenna- 6 Bay (Pole Type), RF cable, junction boxes etc. on the tower. The antenna system and RF feeder cables will be provided by Akashvani. For the sake of completeness of works, the tenderer may have to undertake minor/major items of works that may become necessary for the mounting of antenna system mentioned here to.			
	Section-III			
SCHEDULE OF REQUIREMENTS/MATERIALS (UN-PRICED) FOR 75 M SELF SUPPORTING LATTICE STEEL TOWER				
(I). SUPPLY OF MATERIAL AT SITE: (All the following items shall confirm to detailed Akashvani Specification)				
SI No	Description	Make and model	Quantity	Unit
1	Supply of 75 m tower superstructure materials as per Akashvani Specification complete as required. # Quantity in Metric Ton (MT) offered to be mentioned by tenderer.		#	MT

2	Supply of Vertical ladder materials with Free Fall Prevention system complete as required.		1	Lot
3	Supply of Vertical Cable Rack/Tray materials as per specification complete as required.(Rate per meter shall be quoted)		75	m
4	Supply of Horizontal Cable Rack/Tray materials as per specification complete as required.(Rate per meter shall be quoted)		25	m
5	Supply of 100 mm inner dia. category Class 'C', seamless GI pipe of 18 M length.		1	Job
6	Supply of LED based Aviation Obstruction Light including beacon light (with twin aviation obstruction light arrangement in 'ON' duty and 'STANDBY' mode with alarm) along with Sun-Switch, Control Panel (with MCBs, alarm indicators etc.), Power Supply Cable and accessories etc. complete as required.		1	Set Complete
7	Supply of Lightning Arrester materials/arrangements including earthing materials for separate earthing (2 Nos. earthing) alongwith Copper strip of size 50 mm × 2 mm from top of the tower to the ground with lug etc. complete as required.		1	Set
8	Supply of 3 Core, 6 Sq.mm, Copper Conductor (Standed), XLPE insulated, Sheathed, armoured, weather proof Power Supply Cable with lugs etc. complete as required.		100	m
9	Supply of 32 A, SP&N MCB along with weather proof metal boxes with multipoint power sockets and switches at base and each platforms, earthwire etc. complete as required.		1	Set complete
10	Supply of tower earthing system materials for 75 m tower (4 Nos. earthing) along with copper strips as per specification.		1	Set complete
11	Any other item (s) required for the completeness of the DSETC of 75 m tower. Item wise details (including part No., if any) are to be given by the tenderer.		1	Set
	Total of supply(A)			
	* Length mentioned is for ranking purpose only, however actual running length at sites shall be considered for payment to Tendirer by Akashvani.			
2) WORKS (B)				
Sl. No	Description		Quantity	Unit
1	Preparation and submission of design documents & design drawings of Foundation and Tower structure approved by any IIT/SERC alongwith certificate from IIT/SERC testifying the soundness and safety of design of foundation and tower structure as per Akashvani specification (in hard & soft copies) to Zonal ADG (E). (Within two Months of issue of Acceptance of Tender) - 2 Sets Complete		1	Job
2	Excavation of earth & casting of tower foundation including Supply of complete raw materials, hardware, labour, site clearance etc. as per Akashvani specification complete as required.		1	Job
3	Fabrication, Galvanizing, Painting, Erection, Testing and Commissioning of 75M Self Supporting Lattice Steel tower at site as per Akashvani specification complete as required.		1	Job

4	Fixing of Vertical ladder with Free Fall Prevention System complete as required.		1	Job
5	Fixing of Vertical Cable Rack/Tray with clamps complete as required. (Rate per meter shall be quoted).		75	m
6	Fixing of Horizontal Cable Rack/Tray with clamps complete as required. (Rate per meter shall be quoted).		25	m
7	Fixing of 100 mm dia Class 'C', seamless GI pipe of 20 M length for mounting provisions for VHF FM Antenna complete as required.		1	Job
8	Painting of tower including paint materials complete as required.		1	Job
9	Fixing of LED based Aviation Obstruction Lights along with cable & MCB complete as required.		1	Job
10	Installation of Tower Lightning Arrester and earthing work (2 Nos. earthing) alongwith laying of Copper strip of size 50 mm × 2 mm from top of the tower to the ground with lugs etc. complete as required.		1	Job
11	Hoisting of FM Side Mount Antenna-6 Bay complete as required		1	Job
12	Laying of RF Cable complete as required		1	Job
13	Laying of Power Supply Cable and fixing of weather proof metal boxes with Multipoint Power sockets and switches at base and each platforms, fixing of 32 A, SP&N, MCB including connections, testing etc. complete as required.		1	Job
14	Earthing work for tower (4 Nos. earthing) complete as per Akashvani specification.		1	Job
15	Soil testing with detailed report & document(s) (in soft & hard copies)		1	Job
16	Inspection and certification for structural firmness, verticality and all other design specifications by any IIT/SERC after erection of tower and submission of inspection report & certificate (s) (in hard & soft copies) to Zonal ADG (E).-2 Sets Complete		1	Job
17	Preparation and submission of completion report including photographs showing complete tower as well as each section of 15M length from base to top, horizontal cable tray and foundation processes starting of excavation, steel layout and reinforcements etc. to leveled finished foundation and submission of the same completion report (in soft & hard copies) to: (a) Akashvani Station -1 Set (b) Zonal Office -1 Set (c) Akashvani Directorate -1 Set		1	Job
18	Pre-dispatch inspection of tower materials at the works of tenderer/tower manufacturer		1	Job
19	Any other works required for the completion of DSETC of 75m tower. Break up details of work are to be given by the tenderer.		1	Job
	TOTAL OF WORKS (B)			
20	Additional charges for reduced soil bearing capacity below 8.2 MT/Sq. M for every 0.55 MT/Sq. M decrease.		1	Job
21	Additional charges for requirement of pile foundation or any other type of foundation as approved by any IIT/SERC due to typical soil condition/water table.		1	Job
	TOTAL OF WORKS (C)			

Consignee: Installation Officer, Akashvani No.41,Kalinjur Main Road, Virudhampet, Vellore-632001. Ph.no :0416-2242474

Information to be provided along with Technical bid

1	Due Date of the Tender			
2	Validity of the quotation			
3	Delivery Period			
4	Warranty			
5	Company Registration No			
6	GST Registration No			
7	PAN No			
8	Any other information			

PRICE BID FORMAT/ SCHEDULE OF RATES

Project :		Design, Supply, Erection, Testing and Commissioning (DSETC) of 75 M Self Supporting Lattice Steel Tower including provision of mounting for installation of VHF FM Antenna etc. for Akashvani FM Station at Vellore Tamilnadu- 1 Job. (As per Akashvani Specification)					
BECIL EOI No :		BECIL/GM-1/AIR/75Mtr. Tower /2023-24 Dated: 22-03-2024					
Name of firm / Company :							
Complete Postal Address:							
Quotation No:							
Validity Offer:		180 Days					
Delivery Period:		300 days					
Warranty & Guarantee Period :		5 Years					
S.No.	Description of Items/ works	Qty	Unit	HSN/SAC Code	Make & Model	Unit Cost	Amount
Supply of Material (A)							
1	Supply of 75M tower superstructure materials as per AIR Specification complete as required. # Quantity in Metric Ton (MT) offered to be mentioned by tenderer.		MT		SAIL/RINL/TATA		
2	Supply of Vertical ladder materials with Free Fall Prevention system complete as required.	1	Lot		SAIL/RINL/TATA		
3	Supply of Vertical Cable Rack/Tray materials as per specification complete as required.(Rate per meter shall be quoted)	75	M		SAIL/RINL/TATA		
4	Supply of Horizontal Cable Rack/Tray materials as per specification complete as required.(Rate per meter shall be quoted)	25	M		SAIL/RINL/TATA		
5	Supply of 100 mm inner dia. category Class 'C', seamless GI pipe of 20 M length.	1	Job		TATA/JINDAL		
6	Supply of LED based Aviation Obstruction Light including beacon light (with twin aviation obstruction light arrangement in 'ON' duty and 'STANDBY' mode with alarm) along with Sun-Switch, Control Panel (with MCBs, alarm indicators etc.), Power Supply Cable and	1	Set		Instapower		

	accessories etc. complete as required.						
7	Supply of Lightning Arrester materials/arrangements including earthing materials for separate earthing (2 Nos. earthing) alongwith Copper strip of size 50 mm × 3 mm from top of the tower to the ground with lug etc. complete as required.	1	Set				
8	Supply of 3 Core, 6 Sq.mm, Copper Conductor (Stranded), XLPE insulated, Sheathed, armoured, weather proof Power Supply Cable with lugs etc. complete as required.	100	M		Havells/Finolex		
9	Supply of 32 A, SP&N MCB along with weather proof metal boxes with multipoint power sockets and switches at base and each platforms, earthwire etc. complete as required.	1	Set		Legrend/Havells		
10	Supply of tower earthing system materials for 100M tower (4 Nos. earthing) along with copper strips as per specification.	1	Set Complete				
11	Any other item (s) required for the completeness of the DSETC of 75 M tower. Item wise details (including part No., if any) are to be given by the tenderer.	1	Set				
TOTAL OF SUPPLY (A)							
Works (B)							
1	Preparation and submission of design documents & design drawings of Foundation and Tower structure approved by any IIT/SERC alongwith certificate from IIT/SERC testifying the soundness and safety of design of foundation and tower structure as per AIR specification (in hard & soft copies) to Zonal ADG (E). (Within two Months of issue of Acceptance of Tender) - 2 Sets Complete	1	Job				
2	Excavation of earth & casting of tower foundation including Supply of complete raw materials, hardware, labour, site clearance etc. as per AIR specification complete as required.	1	Job				

3	Fabrication, Galvanizing, Painting, Erection, Testing and Commissioning of 75M Self Supporting Lattice Steel tower at site as per AIR specification complete as required.	1	Job				
4	Fixing of Vertical ladder with Free Fall Prevention System complete as required.	1	Job				
5	Fixing of Vertical Cable Rack/Tray with clamps complete as required. (Rate per meter shall be quoted).	75	M				
6	Fixing of Horizontal Cable Rack/Tray with clamps complete as required. (Rate per meter shall be quoted).	25	M				
7	Fixing of 100 NB Class 'C', seamless GI pipe of 20 M length for mounting provisions for VHF FM Antenna complete as required.	1	Job				
8	Painting of tower including paint materials complete as required.	1	Job				
9	Fixing of LED based Aviation Obstruction Lights along with cable & MCB complete as required.	1	Job				
10	Installation of Tower Lightning Arrester and earthing work (2 Nos. earthing) alongwith laying of Copper strip of size 50 mm × 3 mm from top of the tower to the ground with lugs etc. complete as required.	1	Job				
11	Hoisting of FM Side Mount Antenna-6 Bay complete as required	1	Job				
12	Laying of RF Cable complete as required	1	Job				
13	Laying of Power Supply Cable and fixing of weather proof metal boxes with Multipoint Power sockets and switches at base and each platforms, fixing of 32 A, SP&N, MCB including connections, testing etc. complete as required.	1	Job				
14	Earthing work for tower (4 Nos. earthing) complete as per AIR specification.	1	Job				
15	Soil testing with detailed report & document(s) (in soft & hard copies)	1	Job				

16	Inspection and certification for structural firmness, verticality and all other design specifications by any IIT/SERC after erection of tower and submission of inspection report & certificate (s) (in hard & soft copies) to Zonal ADG (E).-2 Sets Complete	1	Job					
17	Preparation and submission of completion report including photographs showing complete tower as well as each section of 20 M length from base to top, horizontal cable tray and foundation processes starting of excavation, steel layout and reinforcements etc. to leveled finished foundation and submission of the same completion report (in soft & hard copies) to: (a) AIR Station -1 Set (b) Zonal Office -1 Set (c) AIR Directorate -1 Set	1	Job					
18	Pre-dispatch inspection of tower materials at the works of tenderer/tower manufacturer	1	Job					
19	Any other works required for the completion of DSETC of 75 M tower. Break up details of work are to be given by the tenderer.	1	Job					
TOTAL OF WORKS (B)								
20	Additional charges for reduced soil bearing capacity below 8.2 MT/Sq. M for every 0.55 MT/Sq. M decrease.	1	Job					
21	Additional charges for requirement of pile foundation or any other type of foundation as approved by any IIT/SERC due to typical soil condition/water table.	1	Job					
TOTAL OF WORKS (C)								
Total Supply (A)+ WORKS (B)+Additional (C)								
GST								
Grand Total								
SIGNATURE OF THE BIDDER								
SEAL OF THE COMPANY								



PRASARBHARATI
(India's Public Service Broadcaster)
O/o THE ADDITIONAL DIRECTOR GENERAL(E) (SZ)
AKASHVANI & DOORDARSHAN
Swami Sivananda Salai, Chennai -600005
e-mail:adgszpurchase@prasarbharati.gov.in

BID DOCUMENT

For

Design, Supply, Erection, Testing and Commissioning (DSETC) of 75 m Self Supporting Lattice Steel Tower including provisions of mountings for installation of VHF FM Antenna etc. for Akashvani FM Station at Vellore, Tamilnadu– 1 No.(as per Specification)

Bid document Ref. No.: ADG(E)(SZ)PUR/NIT-06/SRMST/2023-24 Date:14.2.2024

Bid Due Date & Time for Online Submission **11.3.2024 at 14:30Hrs.**

Bid Due Date & Time for Bid Opening **11.3.2024 at 15:00Hrs.**

INDEX SHEET

Sl.No.	Name of Documents	Para No	
		Clause No. Sub Section	Page No.
1	E-Tender Notice		
2	Abbreviations		2
3	Contents of Bid document		3
4	Invitation For Bid(IFB)/Bids Data Sheet(BDS)	1	4-8
5	Appendix-A Instruction to Bidders(ITB)	2	9-27
6	Annexure-1,2,4-14(Form1,2,4-14)		28-60
7	Appendix-B General Terms and Conditions (GTC)	3	61-77
8	Appendix-C Bid Evaluation Criteria	4	78-82
9	Appendix-D Description of Stores/DSETC and Technical Specifications	5	83-121
10	Appendix-E State-wise GSTINs of Doordarshan/All India Radio {As per requirement}	6	122
Total Pages:			122

ABBREVIATIONS USED IN THE DOCUMENT

SL NO.	ABRIVIATION	FULL FORM
1	BDS	Bids Data Sheet
2	CPPP	Central Public Procurement Portal
3	CVC	Central Vigilance Commission
4	DP	Delivery Period
5	DSC	Digital Signature Certificate
6	EMD	Earnest Money Deposit
7	FOR	Free on Rail/Road
8	GST	Goods and Service Tax
9	GSTIN	Goods and Service Tax Identification Number
10	GTC	General Terms &Conditions
11	HSN/ SAC	Harmonized System Nomenclature / Service Accounting Code
12	IEM	Independent External Monitor
13	IFB	Invitation for Bid
14	INR	Indian Rupees
15	IP	Integrity Pact
16	ITB	Instructions to Bidders
17	JV	Joint Venture
18	L-1	Lowest Tender
19	LPP	Last Purchase Price
20	MSME	Micro, / Small & Medium Enterprise
21	NEFT	National Electronic Funds Transfer
22	OEM	Original Equipment Manufacture
23	PBG	Performance Bank Guarantee
24	RTGS	Real Time Gross Settlement
25	SITC	Supply, Installation, Testing &Commissioning.
26	SETC:	Supply, Erection, Testing &Commissioning.
27	AITB	Appendix to instruction to Bidders
28	TIS	Tender information Summary

SECTION	CONTENTS	Page No
List of Annexure- FORMS	(Following Forms are to be duly filled and uploaded along with the tender document)	
Annexure-1 FORM-1	Bidder's General Information	27-29
Annexure-2 FORM-2	Bid Submission Form and Agreement	28-30
Annexure-4 FORM-4	PROFORMA of Bank Guarantee(for Bid Bond)	31-34
Annexure-5 FORM-5	Check List	35-36
Annexure-6 FORM-6	Nil Deviation Certificate.	37
Annexure-7 FORM-7	Bidders Past Supplies Proforma	38
Annexure-8 FORM- 8	Declaration Regarding Holiday/Banning	39
Annexure-9 FORM- 9	Letter of Authority	40
Annexure-10 FORM-10	E-Banking Mandate Form	41
Annexure-11 FORM- 11	Eligibility Declaration Form -11	42-44
Annexure-12 FORM- 12	Integrity Pact (Applicable for Estimated value above 2 Crores)	45-53
Annexure-13 FORM -13	Bidder's Queries for Pre Bid Meeting	54
Annexure-14 FORM -14	Proforma for Bank Guarantee for Performance Bond	55-57

1."INVITATION FOR BID (IFB)"

Ref No: ADG(E)(SZ)/PUR/NIT-06/SRMST/2023-24

Date 14.02.2024

Sub: Design, Supply, Erection, Testing and Commissioning (DSETC) of 75 m Self Supporting Lattice Steel Tower including provisions of mountings for installation of VHF FM Antenna etc. for Akashvani FM Station at Vellore, Tamilnadu – 1 No.(as per Specification)

Dear Sir/Madam,

1.1 On behalf of the Prasar Bharati (India's Public service Broadcaster), Akashvani/ Doordarshan, Digitally signed E-tenders are invited from eligible bidders in the prescribed Bid Proforma under Two bid system for supply and works as given in the subject in complete accordance with the following details and enclosed Bid Documents, as prescribed at Annexure,<Form No1,2,4-14>. The details of tender are given below:

1.2 Bid Data Sheet: The brief details of the tender are as under:

1.2.1	Tender Inviting Authority	DDG (Purchase) O/o ADG(E)(SZ) Chennai
1.2.2	Name of the Supply /Work	DSETC of 75 m Self Supporting Lattice Steel Tower including provisions of mountings for installation of VHF FM Antenna etc. for Akashvani FM Station at Vellore, Tamilnadu
1.2.3	Tender Reference No.	ADG(E)(SZ)/PUR/NIT/06/SRMST/2023-24
1.2.4	Place of availability of Tender Documents (RFPs)	1. Procurement Portal of Prasar Bharati http://prasarbharati.eproc.in 2. Website of Prasar Bharati, https://prasarbharati.gov.in/ 3. Central Public Procurement Portal (CPPP): http://www.eprocure.gov.in
1.2.5	Estimated Cost of the Tender	Rupees One Crore and Eighty Lakhs only Rs. 1,80,00,000/-
1.2.6	Tender Processing Fee	Rupees One Thousand Three Hundred and Fifty Seven only Rs. 1357/- (shall be collected through the e-procurement Portal)
1.2.7	Earnest Money Deposit (EMD)	Rs. 3,60,000/- (Rupees. Three lakhs sixty Thousand only)
1.2.8	Address to send Pre bid Queries	Email: adgszpurchase@prasarbharati.gov.in
1.2.9	Nature of bid process	TWO BID System 1.Pre-Qualification (EMD/Bid bond) 2.Technical Bid 3.Commercial Bid
1.2.10	Broad Scope of Work	Refer :Appendix- D
1.2.11	Bid Validity up to:	120 (One Hundred Twenty) days from the date of opening of Technical Bid.

1.2.12	Bid Bond Validity up to :	165 days (Bid validity + 45 days beyond bid validity.)
1.2.13	Date of publication of Bid	Date “ 14.2.2024 ”
1.2.14	Last Date & Time for Submission of written queries by bidders	1.3.24 @ 11:00 A M
1.2.15	Date & Time of Pre- bid Meeting	27.2.2024 @ 11.00 A.M.
1.2.16	Place for Pre-bid meeting	Akashvani FM station, No. 41, Kalinjur Main Road, Virudhampet, Vellore – 632 001.
1.2.17	Opening of Technical bid	11.3.2024 at 15.00 P.M
1.2.18	Opening of Commercial bids	To be informed later
1.2.19	Address for Communication	The Director (Engg) /Asst.Engineer (Purchase) O/o The Additional Director General (E) (SZ) Akashvani and Doordarshan CHENNAI - 600005
1.2.20	Paying Authority	SAO,ADG(E)(SZ), AIR & DD, Chennai IBER
1.2.21	Eligibility to Participate	ITB-clause 2.16
1.2.22	Is this item reserved for exclusive Procurement from MSEs	No
1.2.23	Nature of Bidders eligible – OEMs/ Dealers authorised by OEMs	YES
1.2.24	Entities from countries not eligible to participate on reciprocal basis -(Make in India Policy)	Yes
1.2.25	Minimum local content for eligibility to participate (Make in India Policy)	More than 20%
1.2.26	Classes of Local Suppliers eligible to participate (Make in India Policy)	Only Class-I and Class-II local Suppliers eligible (Domestic Tenders)
1.2.27	Mandatory Joint venture with Indian Company (Make in India Policy)	Yes
1.2.28	Thresholds for Eligibility to Participate and Preference under Make in India Policy	
1.2.28.1	Classification of Local Suppliers based on Minimum local content	[Class-I Local Suppliers - 50% Class-II Local Suppliers - more than20% But less than50% Non-Local Supplier:- lessthan20%)
1.2.28.2	The margin of purchase	20%

- preference
- 1.2.28.3 Is the requirement divisible for preference No**
- 1.2.28.4 Would the contract be split among more than one bidder No**

Note: In case the days specified above happen to be a holiday in Prasar Bharati, the next working day shall be implied.

- 1.3 Instructions to Bidders: As per Appendix-A
- 1.4 General Terms and Conditions: As per Appendix-B
- 1.5 Bid Evaluation Criteria : As Per Appendix-C
- 1.6 Delivery Period: As per Appendix-D.
- 1.7 **Technical Specification: As per Appendix-D.**
- 1.8 The Bid Security/Performance Security from any Indian scheduled Commercial Bank would be acceptable.
- 1.9 **Warranty:** Required as per clause 3.9 of Appendix-B (General Terms and Conditions).
- 1.10 **Performance Security Deposit:** Required as per Clause 3.8 of Appendix-B (General Terms and Conditions) and the Performa for Bank Guarantee is given as Annexure- 14 (Form -14).
- 1.10.1 Amount: 3 % of the value of the contract as specified in Rule 171(i) of GFR,2017or O.M issued by MOF, Dept of Expenditure on 30.12.2021 or it is contingent based on revision of O.M if any at the time of placing order**
- 1.10.2** Performance security shall be valid beyond **Two months** from the date of completion of work /supply on expiry of guarantee whichever is later.
- 1.11 Bids shall be submitted in electronic mode only as per the ITB; EMD/Bid Security have to be submitted in the form of DD/FDR/TDR/Insurance Security Bond/ Bank Guarantee by the bidder before the due date & time of the opening of the bid, and copy of the same shall also be uploaded along with the Technical Bid within the Due Date & Time of Bid Submission, to the address mentioned in Bid Data Sheet (BDS):-
- 1.12 Bidder(s) are advised to submit their bid strictly as per terms and conditions of the Tender Documents and not to stipulate any deviations.
- 1.13 A Nil deviation Certificate as mentioned in the Form-6 shall have to be essentially submitted by the Bidder along with the Technical Bid.
- 1.14 The Tender will be governed by the “Instruction to the Bidder” as per Appendix-A; “General Terms and Conditions” placed at Appendix-B and “Technical Specifications” at Appendix-D. The contract will be governed by Indian laws including the Indian Contract Act, 1872;the Sale of Goods Act, 1930;Right to Information Act, 2005; The Micro, Small and Medium Enterprises Development Act, 2006; Prevention of Corruption Act, 1988; and Arbitration and Conciliation Act, 1996, etc, as amended from time to time. The contract will also be governed by General Financial Rules, 2017, Manual for procurement of goods and works 2017 and 2019, Delegation of Financial Power Rules and any other financial, vigilance, security, safety, counter- trade and other regulatory aspects, orders and

guidelines of the Government on the subject of Public Procurement as amended from time to time in so far as they are applicable and not inconsistent with the conditions mentioned in the tender document.

1.15 Prasar Bharati will follow the reciprocal market access strategy of the Government of India, which describes on the Clause 10 (d) of Public Procurement Preference to Make in India, Order 2017. The Purchaser reserves the right to not consider any Bid and may restrict such Bidders from the bidding process who originate from those countries, where they do not allow market access for Indian companies; in such cases, the Clause 10(d) of Public Procurement Preference to Make in India, order 2017, shall be invoked wherever applicable, when it is relevant

1.16 Single Stage Two Bid Systems shall be followed for this tender. Bidders should take due care to submit tenders in accordance with Bid requirements as specified in clause 2.1 of “Instruction to Bidders” (Appendix-A). Bid evaluation Criteria at Appendix-C shall be the basis for evaluation of tenders.

1.17 For Payment terms pertaining to Supply contracts and SITC/SETC/DSETC Contracts, please refer to clause 2.24 of the tender document.

1.18 As per clause 171(1) of CGST Act, 2017 which relates to anti-profiteering measure, any reduction in rate of tax on any supply of goods and or services or both, the benefit of input tax credit shall be passed on to the recipient by way of commensurate reduction in prices.

1.19 THE FOLLOWING SHOULD BE SUBMITTED ALONG WITH THE TENDER.

1.19.1 Original Equipment's Manufacturer's authorization for equipment quoted.

1.19.2 Documents as specified in Technical Specifications at Appendix-D

1.20 Paying Authority :SAO, O/o ADG(E)(SZ) AIR & DD, Chennai -5

Note: Supplier has to provide Consignee-wise Tax Invoices to respective Bill Processing Authorities. The GST Compliant Invoices should have firm’s GSTIN & Consignee GSTIN.

1.21 Prasar Bharati follows e-tendering Process, Bid shall be submitted only on <https://prsarbharati.eproc.in>. The responsive Bids shall be decided according to various aspects mentioned in ITB, GTC and Eligibility conditions mentioned in the Bid Document. Before the Bid submission, Bidders are advised to refer the help manuals and general FAQs provided in the E-procurement Portal regarding the e-tendering.

1.22 Clarification(s)/Corrigendum(s) if any shall also be available on referred above websites Para 1.2.4. Any revision, clarification, addendum, corrigendum, time extension, etc. to the Tender Document will be hosted on the above-mentioned website(s) only. Bidders are requested to visit the website regularly to keep themselves updated.

1.23 EVALUATION METHODOLOGY: Price evaluation shall be as under: The “Schedule of Rates / Prices” quoted for complete scope of work /Supply inclusive of GST shall be taken up for evaluation, on overall L-1 basis.

1.24 Purchase Preference (Linked with Local Content): Applicable as per government guideline/Tender Document. (Refer Para 4.5)

1.25 In case any cess on GST is applicable same shall also be considered in evaluation.

1.26 The Bidders shall quote FOR destination basis only.

For and on behalf of Prasar Bharati

Name: P.Padmavathi

Designation : Director (Engg)

E-mail ID: adgszpurchase@prasarbharati.gov.in

1. INSTRUCTION TO BIDDERS (ITB)**2.1 INSTRUCTIONS TO BIDDERS FOR ONLINE BID SUBMISSION:**

- 2.1.1 The scope of work / Supply of stores to be tendered are available in the complete bid documents which can be viewed / downloaded free of cost from e-procurement portal of Prasar Bharati, <https://prasarbharati.eproc.in>, or from the website Prasar Bharati, www.prasarbharati.gov.in or CPP Portal <http://eprocure.gov.in>.
- 2.1.2 Both Technical Bid and Financial Bid will be submitted concurrently duly digitally signed on the website <https://prasarbharati.eproc.in>
- 2.1.3 No claim shall be entertained on account of any Technical snag or disruption of internet service being used by bidders. Bidders are advised to upload their bids well in advance to avoid last minute technical snags.
- 2.1.4 All Corrigendum/Amendment/Corrections, if any, will be published on the website <https://prasarbharati.eproc.in> and <http://eprocure.gov.in>.
- 2.1.5 All documents / papers uploaded / submitted by the bidder must be in English and legible.
- 2.1.6 It is mandatory for all the applicants to have Class-III Digital Signature Certificate, with both DSC Components i.e. signing & Encryption, (in the name of the person who will sign the bid document) from any of the licensed Certifying Agency. Bidder may contact the Service provider of e-procurement Portal, at mobile no. +91-8130606629 for DSC related queries or can email at vikas.kumar@clindia.com
- 2.1.7 The Bidders/ Vendors shall be charged the Processing Fees in according with the Estimated Cost of respective Tenders. The following are the charges to be paid by the Bidders /Vendors on the e-procurement portal:

Estimated value of Tender	Processing fees as on 1357.00	
	Per Tender Bidder	Per Total including GST
Less than or Equal to Rs. 10 Lakhs	₹ 475.00 + 18 % GST	₹560.50
More than 10 Lakhs but Less than or equals to 50 Lakhs	₹ 925.00 + 18 % GST	₹1091.50
More than 50 Lakhs	₹ 1150.00 + 18 % GST	₹1357.00
Annual charges for Online Bidder / Vendor for the Registration	₹ 450.00 + 18 % GST	₹531.00

- 2.1.8 To participate in the e-bid, it is mandatory for the Applicants to get themselves registered with the Prasar Bharati e-Tendering Portal (<https://prasarbharati.eproc.in>) to have a user ID & Password which has to be obtained by submitting a non-refundable annual registration charges of Rs. 450/- plus 18% GST through online mode (net banking/debit card/credit card). Validity of Registration is 1 year.
- 2.1.9 Page No. shall be given on each and every paper/documents serially uploaded in the

technical bid.

- 2.1.10 Bidders shall ensure to quote rate of each item. If any cell is left blank and no rate is quoted by the bidders, the rate of such item shall be treated as “0” (Zero).
- 2.1.11 To participate in bidding, bidders have to pay Tender Processing Fee as mentioned in the Para 2.1.7 through online mode (net banking/debit card/credit card).
- 2.1.12 The Bidder may modify or withdraw their bid after submission prior to the Bid Due Date. No Bid shall be modified or withdrawn by the Bidder after the Bid Due Date and Time.
- 2.1.13 The Bid Security/Earnest Money shall be in the form of Account Payee Demand draft, from any scheduled bank(s), Fixed Deposit Receipt (FDR), Insurance surety bond, Bankers Cheque or Bank Guarantee (including e-bank guarantee) from an Indian scheduled Commercial Bank, **in favour of ADG(E)(SZ) Akashvani & Doordarshan Chennai - 5**. In case of EMD Exemption, letter along with NSIC Certificate for MSME in the concerned category of the Tendered items will be submitted.
- 2.1.14 Bid Security/EMD shall be placed in a single sealed envelope superscripted with tender reference no. and date of opening so as to reach **. The Director Engineer. (Purchase)/Assistant Engineer (Purchase) Room No.228, O/o, Additional Director General (E)(SZ), Akashvani and Doordarshan, Swami Sivananda Salai, Chennai-600 005.** before scheduled time on prescribed tender opening date. EMD received after Tender opening date shall be summarily rejected along with the corresponding Tender. Hard copy of any other tender document shall not be accepted. Soft copy of the EMD should be uploaded while submitting bids on e-tendering portal.
- 2.1.15 Micro and Small Enterprises (MSEs) as defined in MSE Procurement Policy issued by Department of Micro, Small and Medium Enterprises (MSME) or are registered with the Central Purchase Organisation or the concerned Ministry or Department or Start-ups as recognised by Department of Industrial Policy & Promotion (DIPP) shall be exempted from payment in respect of cost of Earnest Money as per the Government instructions on the subject on submission of documentary evidence of valid Registration in the concerned category of the Tendered items.
- 2.1.16 The successful Bidders will be required to furnish Performance Security Deposit within 30 days of placement of contract at **the rate of 3 % (Three percent) of value of contract as applicable vide OM issued by MOF, Dept of Expenditure on 30.12.2021 or it is contingent based on revision of OM if any at the time of placing Order** in one of the acceptable forms as per tender documents. Performance Security shall be in the form of Account Payee Demand draft from any scheduled bank(s), Fixed Deposit Receipt (FDR), Insurance surety bonds, or Bank Guarantee (including e-bank guarantee) from an Indian scheduled Commercial Bank in an acceptable form.
- 2.1.17 Technical Bid must contain scanned copy of Unconditional Acceptance of Prasar Bharati’s Tender Terms & Conditions, GST details and EMD etc.
- ~~2.1.18 In case of payment through net banking the money will be immediately transferred to Prasar Bharati’s designated Account through from any scheduled bank(s), the bidder will have to furnish the UTR Remittance Number(s) before submission of bid, payment details shall also be uploaded on procurement portal along with Bid. The payment of EMD through NEFT /RTGS mode should be made well ahead of time to ensure that the EMD amount is transferred to Prasar Bharti account before submission of bid.~~
- 2.1.19 The financial Bid shall be opened only of those Bidder(s) found to be meeting the

Technical qualifying requirements. In case of non-responsive Bids, Financial Bids shall not be opened. The opening date of financial bid will be decided later on and same will be informed to eligible Bidders in advance.

- 2.1.20 **Bidders are advised to submit written queries in advance of the Pre-Bid Meeting.** The Form # 13 can be used for this purpose. After the Meeting, the techno-commercial requirements may be revised, if considered necessary. After that no request/query will be entertained.
- 2.1.21 Prasar Bharati reserves the right to accept or reject any or all applications without assigning any reasons. Prasar Bharati also reserves the right to annul the tender process at any stage without assigning any reason.
- 2.1.22 If any clarification is needed from the bidder about the deficiency in his uploaded documents, he will be asked to provide it through e-procurement portal of Prasar Bharati/e-mail. The bidder shall upload the requisite clarification/documents within time specified by Prasar Bharati, failing which tender will be liable for rejection.
- 2.1.23 Prasar Bharati reserves the right to reject whose performance at ongoing Supply/ Work(s) is below par and usually poor and has been issued letter of restrain/Temporary/Permanent debar by any office of Prasar Bharati, Government or Public sector. (Rule 151, GFR 2017) Prasar Bharati reserves the right to verify the credential submitted by the agency at any stage (before or after the award of the work). If at any stage, any information /documents submitted by the applicant is found to be incorrect/false or have some discrepancy which disqualifies the firm then Prasar Bharati shall take the following action:
- 2.1.23.1 Forfeit the entire amount of EMD submitted by the firm.
- 2.1.23.2 The agency shall be liable for debarment from tendering in Prasar Bharati, apart from any other appropriate contractual/legal action.
- 2.1.23.3 Public procurement policy for Micro, small and medium enterprises registered under MSME shall be followed as per the directives of Government of India prevailing at the date of acceptance
- 2.1.24 Bidders have to submit a GST Registration Certificate while uploading the tender.
- 2.1.25 **Bidders shall separately indicate the HSN/SAC code, rate and amount of GST for each quoted item as applicable on the date of tendering in their offer, failing which the offer may be rejected.**
- 2.1.26 IGST and Compensation Cess (wherever applicable) will be levied on imports.
- 2.1.27 Terms& Conditions given in Technical specifications will supersede for conflict with any terms & conditions given in Tender Document.
- 2.1.28 **For Consortium / Joint Venture :**

In case of a Consortium/JV, Power of Attorney issued by Board of Directors/ Chairman/CEO / MD / Company Secretary of the Consortium Lead Member as well as Consortium Member(s) of the Consortium/ partners of JV, in favour of the authorised employee(s) of the Consortium /Lead member of JV, for signing the documents on behalf of the Bidder, in respect of this particular tender, to sign the Bid and all subsequent communications, agreements, documents etc. pertaining to the tender and act and take

any and all decisions on behalf of the Consortium/JV, are to be submitted.

- 2.1.29 The authorized employee(s) of the Bidder shall be signing the Bid and any consequence resulting due to such signing shall be binding on the Bidder.
- 2.1.30 Bids from consortium/ JV of two or more members (maximum 3 nos. Including Leader) are acceptable provided that they jointly fulfill the qualification criteria and requirements stated in the Tender Documents. Participating Consortium/ JV shall submit the Agreement, clearly defining the scope and responsibility of each member. Members of consortium/ JV shall assume responsibility jointly & severally. The bid security shall be submitted by the Lead Bidder of the Consortium/ JV. In case of award, payment shall be made to the Lead Bidder of the Consortium/JV.
- 2.1.31 The Consortium/ JV Agreement must clearly define the Consortium Leader/ Lead Partner of JV, who shall be responsible on behalf of the Consortium/JV during the period of evaluation of the bid as well as during the execution and timely completion of all the contractual obligations and shall receive/ send instructions for and on behalf of the Consortium/JV.
- 2.1.32 A Consortium/ JV once established at the time of submitting the Bid shall not be allowed to be altered with respect to constituting members of the Consortium/ JV or their respective roles/ scope of supply/work, except with prior written approval of Prasar Bharati. If during the evaluation of bids, a Consortium/JV propose any alteration/ changes in the orientation of Consortium/JV or replacements or inclusions or exclusions of any partner(s)/ member(s) which had originally submitted the bid, bid from such Bidder shall be liable for rejection.
- 2.1.33 Any member of the Consortium/ JV shall not be eligible either in an individual capacity or be a part of any other Consortium/JV to participate in this tender. Further, no member of the Consortium/ JV should have been put on 'Holiday' or banned/ blacklisted by PrasarBharati/ Government department/ Public Sector as on the due date of submission of bid. Offer submitted by such Consortium/ JV shall not be considered for opening/evaluation/Award

2.2 ONE BID PER BIDDER

- 2.2.1 A Bidder shall submit only 'one [01] Bid' in the same Bidding Process. A Bidder who submits or participates in more than 'one [01] Bid', will cause all the Bids in which the Bidder has participated to be disqualified.
- 2.2.2 Alternative Bids shall not be considered.
- 2.2.3 Any Bidder having formed a JV/Consortium shall not be considered eligible to make JV/ consortium with any other bidder or form part of any other JV/Consortium and submit a Bid for the same tender.

2.3 COST OF BIDDING

- 2.3.1 The Bidder shall bear all cost associated with the preparation and submission of the Bid including but not limited to Documentation Charges, Bank charges, all courier charges, translation charges, authentication charges and any associated charges including taxes & duties thereon. Further, Prasar Bharati will in no case be responsible or liable for these costs, regardless of the outcome of the bidding process.
- 2.3.2 The Bidder shall not be entitled to hold any claim against Prasar Bharati for non-compliance due to lack of any kind of pre-requisite information as it is the sole responsibility of the Bidder to obtain all the necessary information with regard to site,

surrounding, working conditions, weather etc. on its own before submission of the Bid.

2.4 For more information regarding submission of Bid in the e- Procurement portal, Bidders may refer the help manuals and, General FAQs (Frequently Answered Questions) about the e-Tendering, which has been provided in the Portal.

2.5 LIST OF DOCUMENTS(to be uploaded with tender):

2.5.1 PART-I: "TECHNO-COMMERCIAL / UNPRICED BID"

- 2.5.1.1 'Covering Letter' on Bidder's 'Letter head' clearly specifying the enclosed contents.
- 2.5.1.2 'Bidder's General Information', as per 'Form-1' along with Copy of 'PAN' and 'GST' registration and 'Bid Form', as per 'Form-2'
- 2.5.1.3 Scanned copy of EMD along with Form-4 or Declaration of MSME EMD Exemption letter along with NSIC Certificate for MSME in the concerned category of the Tendered items.
- 2.5.1.4 Copies of documents required as per 'Form -5' and as mentioned elsewhere in the Tender Document
- 2.5.1.5 Nil deviation Certificate as per 'Form-6'.
- 2.5.1.6 Bidders Past Supplies Proforma as per Form 7
- 2.5.1.7 Declaration regarding Holiday/Banning, in 'Form-8
- 2.5.1.8 Letter of Authority' on the Letter Head, as per 'Form-9
- 2.5.1.9 AIR/DD's Technical Specifications duly signed on each page.
- 2.5.1.10 Original Equipment's Manufacturers (OEM) Authorization for Equipment quoted.
- 2.5.1.11 Letter of authority to sign and upload bid documents.
- 2.5.1.12 Undertaking regarding Fall Clause as mentioned in Para 3.22.3
- 2.5.1.13 Enclosures as per Commercial requirement.
- 2.5.1.14 Enclosures as per Technical requirement.
- 2.5.1.15 Self-Certificate for Local Content as per Form-11.
- 2.5.1.16 ~~Integrity Pact as per Form 12 (if applicable)(for estimated contract value of Rs. Two Crores or more) duly filled and signed.~~
- 2.5.1.17 Certificates as mentioned on Para 2.33.8 along with evidence of valid registration by the Competent Authority to be attached, if applicable.
- 2.5.1.18 Any other information/details required as per Tender Document

2.5.2 PART-II: Price Bid

(As per the Tender, the reference of the Schedule of Rate may be specified here)

- 2.6 All GTC attached with the "Invitation to Tender" are sacrosanct for considering any offer as a complete offer. It is therefore important that all documents duly completed and signed are returned with the Bidder's offer.
- 2.7 Prasar Bharati shall have all right to ignore any offer which fails to comply with the above instructions.
- 2.8 The Bid shall be submitted online not later than the time specified in the tender document, or on the notified date of closing of the tender. Offers sent through any mode other than uploading on e-procurement portal of Prasar Bharati will not be accepted.
- 2.9 Any change in quotation after opening of tender will not be considered. Bidders must ensure that all the documents / files uploaded on e- procurement portal are in order and legible in all respect. Prasar Bharati will not be responsible for any documents / files illegible or corrupted due to any disruption/ technical snag of internet service being used

by the bidders.

2.10 VAGUE AND INDEFINITE EXPRESSION

Tenders qualified by vague and indefinite expressions such as "subject to immediate acceptance" or "subject to prior sale" etc. will not be considered. Unconditional Bids shall only be considered.

2.10.1 VALIDITY PERIOD OF OFFER

2.10.1.1 The Tender shall be valid for acceptance for the period as indicated in the "Invitation to Bid" (hereinafter referred to as validity period) and shall not be withdrawn on or after the opening of tenders till the expiration of the validity period or any extension thereof.

2.10.1.2 The offers of these Bidders who have not kept the validity open till the period stipulated in the tender will be treated as unresponsive and will be ignored without making any back reference.

2.10.1.3 The Bidder will undertake not to vary/modify the tender during the validity period or any extension thereof.

2.11 OPENING OF TENDERS

2.11.1 The tender will be opened online on the e-tendering portal of PrasarBharati <https://prasarbharati.eproc.in> at the time specified in the tender document, on the date of opening indicated in the "Invitation to Bid.", in the presence of bidders authorized representatives who choose to attend.

2.11.2 In case of unscheduled holiday on the closing/opening day of tender, the next working day will be treated as scheduled prescribed day of closing/opening of tender; the time notified remains the same.

2.11.3 PRICES FOR BIDDERS

Bidders are to quote in INR only on FOR Destination basis.

2.12 VARIATION OF QUANTITIES (Ref: PARA 7.5.3 MFP 2017)

At the time of awarding the contract, Prasar Bharati shall have right to re-judge the quantity to be procured based on the current data, since the ground situation may have very well changed. The tendered quantity can be increased or decreased by 25 (Twenty-Five) per cent for ordering, if so warranted.

2.13 OPTION CLAUSE:

Prasar Bharati reserves the right to increase/decrease the ordered quantity by up to 25 (Twenty Five) per cent at any time, till final delivery date (or the extended delivery date of the contract), by giving reasonable notice even though the quantity ordered initially has been supplied in full before the last date of the delivery period (or the extended delivery period)

2.14 TAX LIABILITY

2.14.1 The Bidder shall be entirely responsible for all taxes, duties, license fees, etc., incurred till its final manufacture/ production upto the point of delivery. Further instruction, if any, shall be as provided in the Schedule of Requirements.

2.14.2 Payment of CGST/SGST/UTGST/IGST and all other applicable taxes (on ultimate products and Services) and custom duty, as applicable on the closing date of tender will be to supplier's /contractor's account. In the case of "Two Bid" system where revised price bids are permitted after technical discussions payment of these charges as applicable on closing day of revised price bids, will be to supplier's /contractor's account. Any

increase over the rate existing on the last date of submission of Bid shall be reimbursed by the Organisation on production of documentary evidence in support of payment actually made to the concerned authorities. Similarly, if there is any decrease in such duties, taxes and levies the same shall become recoverable from the contractor. The details of such duties, taxes and other levies along with rates shall be declared by the bidder.

- 2.14.3 The bidder(s) will indicate in their bid the amount with exact rate of customs duty and the applicable item of custom tariff under which it is covered. Similarly, the amount of CGST/SGST/UTGST/IGST and all other applicable taxes on ultimate furnished product with HSN/SAC code, as applicable at tendering stage will be shown separately in the bid. In case the above information subsequently proves wrong incorrect or misleading
- (a) This Organization will have no liability to reimburse the excess in the difference in rates of the item under which the duty/ tax assessed finally
 - (b) This Organization will have the right to recover the difference in case the rate of duty/ tax finally assessed is on the lower side.
- 2.14.4 Contractor shall ensure timely submission of invoice(s) as per rules/ regulations of GST with all required supporting document(s) to enable Prasar Bharati to avail Input Tax Credit (ITC). Further, returns and details required to be filed under GST laws & rules should be timely filed by supplier with requisite details.
- 2.14.5 If input tax credit (ITC) with respect to GST (CGST & SGST/UTGST or IGST) which normally shall be available to Prasar Bharati, is not available, for any reason, which is not attributable to Prasar Bharati, then Prasar Bharati shall not be obliged or liable to pay or reimburse GST (CGST & SGST/UTGST or IGST) charged in the invoice(s) and shall be entitled to/ deduct/ setoff/ recover the such GST (CGST & SGST/UTGST or IGST) thereupon together with all penalties and interest if any, against any amounts paid or payable by Prasar Bharati to Supplier/ Vendor.
- 2.14.6 The rates and prices quoted by the Bidder shall be fixed for the duration of the contract and shall not be subject to variations on any account except to the extent variations allowed as per the conditions of the contract of the bidding document.

2.15 TRADE/ VOLUME DISCOUNT

Bidders will not indicate a separate discount. Discount, if any, should be merged in the rates against the quoted items(s). Discount of any type indicated separately will not be taken into account for evaluation purposes.

2.16 ESSENTIAL ELIGIBILITY CRITERIA FOR TENDERER

(Kindly refer : Clause (B)/Page No.2 &3 of tender specifications)

- 2.16.1 Bids should preferably be from original manufacturers, however, Bids from sole selling agents/authorized distributors/authorized dealers can also be considered provided such bids are accompanied with necessary supporting documents/authority letter from concerned original manufacturer who authorized them to market their product, provided further, such an authority letter is valid at the time of bidding. Required Warranty Cover of the manufacturer for the product will be provided by such a supplier through OEM. The Bidder shall not be under a declaration of ineligibility by Purchaser for Corrupt/ Fraudulent/ Collusive/ Coercive practices,
- 2.16.2 The Bidder is not put on 'Holiday' by Prasar Bharati or any of the Government

departments, Public Sector or banned/blacklisted by Government department/ Public Sector on the due date of submission of bid. If the Bid submitted by such Bidder shall not be considered for opening/ evaluation/ award and in case of Manual Tendering, such Bid along with the Bid Security, if any, will be returned immediately to the Bidder.

2.16.3 **Bidder should meet experience and other criteria, if any as specified in Appendix-D** and basic guidelines/ eligibility criteria as under:

2.16.3(a) Company Existence : Company should be registered under Companies Act, 1956 or Companies Act 2013 or a Partnership firm / LLP registered in India under Partnership Act 1932/2008 as amended and should have been in operations in India in the last 3 Years

2.16.3(b) Annual Turnover/ Net Worth (CA certified documents) (Except the Covid FYs 2020-21 and 2021-22)

Average Annual turnover of 200% of estimated cost of the project in the last 03 financial years

OR

Cumulative Turnover of 600% of estimated cost of the project in the last 03 financial years

OR

Average Annual Net Worth of minimum of 50% of estimated cost of the project in the last 03 financial years

OR

Cumulative Net Worth of minimum of 150% of estimated cost of the project in the last 03 financial years

2.16.3(c) Positive Net Worth/ Profitability : Profitability/ positive net worth in the last financial year

Solvent entity (CA certified document)

2.16.3(d) Work Experience (Self-certified with relevant documents): *One* Similar work of minimum value of 80% of estimated cost of the project

OR

Two Similar works of minimum value of 60% of the estimated cost of project

OR

Three Similar works of minimum value of 40% of the estimated cost of project

Note: Similar works will be defined based on scope of the work. Similar works may be executed with any Central and State Government agency, PSUs, Private organizations.

2.16.3(e) Non-Blacklisting Certificate : The bidder should not have been blacklisted /debarred by any Governmental / Non-Governmental Organization in India as on bid submission date.

2.16.3(f) Certification: The Bidder should have valid ISO 9001:2008/ ISO 9001:2015/ ISO 27001 (relevant certification based on type of work) valid as on bid submission

2.16.3(g) GFR Restrictions/ Norms: Bidder complies with restrictions on procurement under Rule 144(xi) vide order no: 06/18/2019-PPD dated 23rd July 2020 inserting in Rule 144(xi) GFR 2017

2.16.3(h) Preferential Market Access (PMA) Bidder should comply with Preferential market Access (PMA) order 2017, guidelines notified by DPIIT and DoT with all its clarifications/amendments, if applicable.

However nothing in this shall prevent Prasar Bharati from engaging new and emerging Technology start-ups in the areas of R&D and innovation from time to time. Relaxation for Start-ups as per Government guidelines would apply (GFR Rule 173(1) relaxes DPIIT recognized Start-ups from prior experience and prior turn over requirements subject to meeting of quality and technical specifications and making suitable provisions in the Bid Document).

2.17 **PURCHASE PREFERENCE**

2.17.1 Purchase preference to Central Government Public Sector Undertaking, Micro, Small & Medium Enterprises (MSMEs) and Domestically Manufactured Electronic Products (DMEP) shall be allowed as per Government instructions in vogue, as applicable necessary supporting documents to be furnished by the bidder.

2.17.2 Public Procurement (Preference to Make in India) Order No. P-45021/2/2017-B.E-II dated 15.06.2017 of Government of India, Ministry of Commerce and Industry, Department of Industrial Policy and Promotion and its amendments shall be applicable. Purchase preference for the domestic manufacturer, the methodology of its implementation, value addition to be achieved by domestic manufacturers, self-certification, and modalities for compliance and monitoring shall be as per the Para 4.5.

2.18 SCOPE OF SUPPLY OF EQUIPMENT/SITC/SETC/DSETC:

The delivery of the stores/execution of SITC/SETC/DSETC is required as stated in “Invitation to Bid” on terms specified in the description of Stores/SITC/SETC/DSETC and Technical Specifications mentioned at Appendix-D , subjected to the terms “General Terms and Conditions” at Appendix-B.

2.19 CONSIDERATION OF OFFER IN FULL OR IN PART

This Organisation may reject/accept or prefer any tender without having to assign any reason whatsoever. This Organisation also reserves to itself the right to accept any tender in part or split the order between two or more bidders.

2.20 SPECIFICATIONS

2.20.1 If this Organisation finds that materials supplied/works carried out are not of correct quality, quantity and are not according to required specifications or are not satisfactory owing to any reason of which the Organisation will be the sole judge, the Organisation will be entitled to cancel the contract for supply of stores/SITC/SETC/DSETC and meet its requirements of stores/SITC/SETC/DSETC from the open market at the risk and cost of the supplier/contractor, reserving always to itself the right to forfeit the security deposit placed by the supplier/contractor for fulfillment of the contract.

2.21 BID SECURITY/ EARNEST MONEY/SECURITY DEPOSIT/PERFORMANCE BOND:

2.21.1 **Earnest Money/Bid Bond** :The bidders must submit Earnest Money Deposit on or before the last date & time of submission of bid in the form of FDR, TDR, Banker’s cheque, Account Payee Demand Draft or Bank Guarantee of any Scheduled Commercial Bank in India in case of Indian supplier or Bank Guarantee/Demand Draft in equivalent Indian currency from a Scheduled Commercial Bank in favour of **ADG(E)SZ AIR & DD Chennai** or in lieu thereof bid bond in the enclosed Proforma at Form - 4 from a Scheduled Indian Commercial Banks for the amount specified in Para 1.2.7 of “Invitation to Bid”. In case of Bank Guarantee obtained from the foreign Bank, it should be guaranteed by a Scheduled Indian Commercial Bank and must be governed by Indian Laws subject to jurisdiction of the court of New Delhi. The bid bond should initially be valid up to 45 days beyond the period of Bid validity (except for the Demand draft whose validity should be 90 days).

2.21.2 Offers without Earnest Money/Bid Security will be ignored. Offers with Earnest Money /Bid Security deposited of shorter validity will also be ignored.

2.21.3 Bidders exempted from EMD are to submit required documents.

2.21.4 The earnest money/bid bond of unsuccessful bidders will be returned on finalization or after the award of the Tender to the Lowest Bidder(L1), and the earnest money/bid bond of the successful bidder will be returned on receipt of requisite security

deposit/Performance Bond.

2.21.5 **FORFEITURE OF EMD:** The earnest money/Bid bond deposited by the Bidder shall be forfeited by this Organization in the following events:

2.21.5.1 If tender is withdrawn during the validity period or any extension thereof;

2.21.5.2 If Bid is amended or modified unsolicited, during the validity period or any extension thereof;

2.21.5.3 If a Bidder, whose tender has been accepted, fails to furnish Security deposit, performance bank guarantee within 30 (Thirty) days of the receipt of order/ advance order/ letter of intent;

2.21.5.4 In case of tenders in which only a single bidder qualifies or in cases of procurement on PAC basis, if the Bidder decides at any stage not to participate further in the tender but in spite of withdrawing on his own, he deliberately delays the tendering process to let the validity period expire;

2.21.5.5 If, the bidder is not earnest about their bid, and withdraws it before the completion of Technical Evaluation against the accepted specification, at the time of bidding and before the validity period or any extension thereof;

2.22 **SECURITY DEPOSIT/PERFORMANCE BOND.**

The successful bidder, within 30 (Thirty) days of the receipt of order/advance order/letter of intent, will be required to send Security Deposit in the form of Account Payee Demand draft, from any scheduled bank(s), Fixed Deposit Receipt (FDR), Bankers Cheque or Bank Guarantee from an Indian scheduled Commercial Bank favour of **ADG(E)SZ Akashvani and Doordarshan, Chennai** in lieu thereof Performance Security/Bank Guarantee for the amount as indicated in the Para 1.10 of "Invitation to Bid".

2.23 **NAME OF MANUFACTURER AND CERTIFICATE OF ORIGIN**

The name of the manufacturer should be clearly mentioned in the offer. The Bidder shall have to furnish information of country of origin of each offered item.

2.24 **PAYMENT TERMS**

Schedule of Payments: (Kindly refer :Payment terms Clause–C / P.No.4 &5 of tender specification)

[Payment will be made by OFFICE OF THE ADDL.DIRECTOR GENERAL (E) (SZ)ALL INDIA RADIO & DOORDARSHANSWAMI SIVANANDA SALAI, CHENNAI-600 005.]

2.24.1 Ordinarily, Prasar Bharati (PB) would disburse payments for services rendered or supplies made, only after the services have been rendered or supplies made. However, in case of supply of services and turnkey projects and maintenance contracts, advance payment might be considered only on request of the contractor/supplier in cases where it is considered absolutely necessary and justification accepted by Prasar Bharati (PB).

2.24.2 Advance payment will only be released after submission of an unconditional Bank Guarantee by the contractor/supplier. The Bank Guarantee shall be from a Commercial bank acceptable to the Procuring Entity in amounts equal to 110% (one hundred ten percent) of the amount of the advance payment being requested and subsequent verification of the Bank Guarantee. The Bank Guarantee shall remain effective until the advance payment has been adjusted. The amount of advance payment against contract for supply of stores shall be restricted to:

1. Thirty per cent of the contract value (without taxes) to private firms;
2. Forty per cent of the contract value (without taxes) to a state or central Government agency or PSU;
3. In case of maintenance contract, the amount shall not exceed the amount payable for six months under the contract.

2.24.3 An assurance in the shape of indemnity bond/insurance shall be submitted by the vendor in every case where advance payment is to be made. The goods supplied under the contract, shall be fully insured by the contractor/supplier in a freely convertible currency against loss or damage incidental to manufacture or acquisition, transportation, storage and delivery in the manner specified in the contract. The amount to be covered under insurance should be sufficient to take care of the overall expenditure to be incurred by the procuring entity for receiving the goods at the destination.

2.24.4 The advance paid shall be progressively adjusted against bills within the schedule of payments along with the applicable taxes.

2.24.5 Normally, interest shall not be charged on the advance payment. However, in case of breach of contract by the supplier/contractor and thereby termination of contract by Prasar Bharati, the Advance shall be deemed an interest-bearing advance at the prevailing rate (MIBID - Mumbai Interbank Bid Rate) on the date of such advance payment

~~2.24.5.1 For Supply Contracts: N.A~~

~~The supplier will submit bill for 90% of the basic amount and 100% of the GST applicable on the total basic amount along with a copy of Inspection Notes and provisional Consignees Receipt certificate to concerned Zonal Offices who will, after verifying bills, pass on to the respective PAOs for making payment. The bill for the balance 10% basic amount shall be submitted by the suppliers after receipt of final consignees receipt certificates.~~

~~2.24.5.2 For SITC/SETC/DSETC Contracts:~~

~~The supplier will submit bill for 80% of the material/equipment basic cost and 100% of the GST applicable on the total basic amount of material/equipment supplied along with a copy of Inspection Notes and Provisional consignees Receipt certificate to concerned Zonal Offices who will, after verifying bills, pass on to the respective PAOs for making payment. The bill for balance 20% of material/equipment cost along with 100% installation/Erection, Testing & commissioning charges, if any, shall be submitted by the suppliers after receipt of final consignees receipt certificates and satisfactory installation/Erection, Testing& commissioning certificate whichever required.~~

~~(Note: GST shall be paid only once against an order. Supplier will submit invoice accordingly.)~~

~~2.24.2 The payment shall be made on receipt of the goods by the consignee and upon submission of following documents.~~

- ~~a. The supplier's invoice showing contract number, description of goods, quantity, unit price and the total amount;~~
- ~~b. Delivery note;~~
- ~~c. Packing list identifying contents of each package;~~
- ~~d. Certificate of origin.~~
- ~~e. Provision receipt certificate for the corresponding delivery, issued by the consignee indicating acceptance of materials at site in good condition;~~
- ~~f. Any other document(s) and/or modification of above documents specified in the Schedule of Requirement and the contract.~~

2.25 UNSOLICITED POST TENDER MODIFICATION

- 2.25.1** In case certain clarifications are sought by this Organisation after opening of tenders, then the reply of the bidder should be restricted to the clarifications sought.
- 2.25.2** Any bidder who modifies his bid(including a modification which has the effect of altering the value of his offer) after the closing date without specific reference by this Organisation shall render the bid liable to be ignored and rejected without notice and without further reference to the bidder.
- 2.25.3** Canvassing in any form by the bidders shall also render the bid liable to be ignored and rejected without notice and without further reference to the bidder.
- 2.26** **CLARIFICATION IN RESPECT OF INCOMPLETE OFFERS**
- 2.26.1** This Organisation has to finalize its purchase within a limited time schedule. Therefore, it may not be feasible in all cases for this Organisation to seek clarifications in respect of incomplete offers. Prospective bidders are advised to ensure that their bids are complete in all respects and conform to our terms and conditions and Bid Evaluation Criteria of the tender. Bids not complying with this Organisation's requirements may be rejected without seeking any clarifications. However during evaluation and comparison of bids, Prasar Bharati at its discretion, may ask the bidder for clarifications on the bid. The request for clarification shall be given in writing by registered email Id or through e-procurement Portal, asking the Bidder to respond by a specified date, and also mentioning therein that, if the Bidder does not comply or respond by the date, his Bid will be liable to be rejected. Depending on the outcome, such tenders will be ignored or considered further. No change in prices or substance of the bid shall be sought, offered or permitted. No post bid clarification at the initiative of the bidder shall be entertained.
- 2.26.2** The Bidder shall quote the prices in 'figures' & words. There should not be any discrepancy between the prices indicated in figures and the price indicated in words. In case of any discrepancy, the same shall be dealt as follows:
- 2.26.2.1** When there is a difference between the rates in figures and words, the rate which corresponds to the amount worked out by the Bidder (by multiplying the quantity and rate) shall be taken as correct.
- 2.26.2.2** When the rate quoted by the Bidder in figures and words tallies but the amount is incorrect, the rate quoted by the contractor shall be taken as correct and not the amount and the amount corrected.
- 2.26.2.3** When it is not possible to ascertain the correct rate, in the manner prescribed above, the rate as quoted in words shall be adopted and the amount worked
- 2.27** **AFTER SALES SERVICE AND TRAINING- (as applicable as per Technical Specification)**
- 2.28** **REPLACEMENT/ RECTIFICATION**
In the event the stores supplied or SITC/SETC/DSETC carried out against the contract are found to be defective, the supplier/contractor will have to take back the defective materials at his own cost and replace/rectify the defects of the Stores/SITC/SETC/DSETC free of charge without loss of time. The supplier will not be entitled to dispose of the store/equipment/material given for replacement/rectification without the prior permission of this Organisation. All charges concerned with the rectification including freight charges will be borne by the supplier/contractor.
- 2.29** **EVALUATION/ SCRUTINY OF BIDS.**
In evaluation of the techno-commercial bid, conformity of the eligibility/qualification, technical and commercial conditions of the offered goods to those in the bid document is

ascertained. Technical requirement, incorporated in the Appendix-D of tender documents will also be considered in the manner indicated therein. Evaluation will be based only on the conditions included in the tender document.

2.30 SIGNING OF AGREEMENT

2.30.1 Prasar Bharati will award the Contract to the successful Bidder, who, within 'fifteen [15] days' of receipt of the same, shall sign and return the acknowledged copy to Prasar Bharati.

2.30.2 The successful Bidder/Contractor shall be required to execute an 'Agreement' in a Performa on a 'non-judicial stamp paper' of appropriate value [cost of the 'stamp-paper' shall be borne by the successful Bidder/Contractor] and of 'state' specified only, within 'thirty [30] days' of receipt of the "Letter of Acceptance [LOA]" of the Tender by the successful Bidder/Contractor failure on the part of the successful Bidder/Contractor to sign the 'Agreement' within the above stipulated period, shall constitute sufficient grounds for appropriate action per tender provisions.

2.30.3 If the Bidder or any employee of the Bidder or any person acting on behalf of the Bidder, either directly or indirectly, is a relative of any of the employee of Prasar Bharati, or alternatively, if any relative of an employee of Prasar Bharati has financial interest/stake in the Bidder's firm, the same shall be disclosed by the Bidder at the time of filing of tender. The term 'relative' for this purpose would be as defined in Section 6 of the Companies Act 1956.

2.30.4 The Bidder shall not lend to or borrow any money from or enter into any monetary dealings or transactions, directly or indirectly, with any employee of Prasar Bharati

2.31 EMPLOYMENT BY FIRMS TO OFFICIALS OF THIS ORGANISATION.

Firms/companies who have or had business relations with the Organisation are advised not to employ serving employees of this Organisation without its prior permission or within the initial one-year period after the retirement/resignation/severance from the service without specific permission of this Organisation. This Organisation may decide not to deal with such firms who failed to comply with the above advice.

2.32 CANCELLATION /RESCISSION:

The Bidder shall be liable to pay compensation for any loss or damage to Prasar Bharati resulting from any cancellation/rescission due to the reasons attributable to the Bidder and the Prasar Bharati shall be entitled to deduct the amount so payable from the amount due to the Bidder.

2.33 FOR THE BIDDER FROM A COUNTRY WHICH SHARES A LAND BORDER WITH INDIA

2.33.1 Any bidder from a country which shares a land border with India will be eligible to bid in this tender only if the bidder is registered with the Competent Authority. The Competent Authority for the purpose of registration under this Order shall be the Registration Committee constituted by the Department for Promotion of Industry and Internal Trade (DPIIT).

2.33.2 "Bidder" (including the term 'tenderer', 'consultant' or 'service provider' in certain

contexts) means any person or firm or company, including any member of a consortium or joint venture (that is an association of several persons, or firms or companies), every artificial juridical person not falling in any of the descriptions of bidders stated hereinbefore, including any agency branch or office controlled by such person, participating in a procurement process.

- 2.33.3 "Bidder from a country which shares a land border with India" for the purpose of this Order means; -
- 2.33.3.1** An entity incorporated, established or registered in such a country; or
- 2.33.3.2** A subsidiary of an entity incorporated, established or registered in such a country; or
- 2.33.3.3** An entity substantially controlled through entities incorporated, established or registered in such a country; or
- 2.33.3.4** An entity whose beneficial owner is situated in such a country; or
- 2.33.3.5** An Indian (or other) agent of such an entity; or
- 2.33.3.6** A natural person who is a citizen of such a country; or
- 2.33.3.7** A consortium or joint venture where any member of the consortium or joint venture falls under any of the above
- 2.33.4 The beneficial owner for the purpose of Para 2.33.3 above will be as under:
- 2.33.4.1** In case of a company or Limited Liability Partnership, the beneficial owner is the natural person(s), who, whether acting alone or together, or through one or more juridical person, has a controlling ownership interest or who exercises control through other means. Explanation—
- 2.33.4.1.1 "Controlling ownership interest" means ownership of or entitlement to more than twenty-five per cent of shares or capital or profits of the company;
- 2.33.4.1.2 "Control" shall include the right to appoint majority of the directors or to control the management or policy decisions including by virtue of their shareholding or management rights or shareholders agreements or voting agreements;
- 2.33.4.1.3 In case of a partnership firm, the beneficial owner is the natural person(s) who, whether acting alone or together, or through one or more juridical person, has ownership of entitlement to more than fifteen percent of capital or profits of the partnership;
- 2.33.4.1.4 In case of an unincorporated association or body of individuals, the beneficial owner is the natural person(s), who, whether acting alone or together, or through one or more juridical person, has ownership of or entitlement to more than fifteen percent of the property or capital or profits of such association or body of individuals;
- 2.33.4.1.5 Where no natural person is identified under Para 2.33.4.1 or Para 2.33.4.2 or Para 2.33.4.3 above, the beneficial owner is the relevant natural person who holds the position of senior managing official;
- 2.33.5 In case of a trusty the identification of beneficial owner(s) shall include identification of the author of the trust, the trustee, the beneficiaries with fifteen percent or more interest in the trust and any other natural person exercising ultimate effective control over the trust through a chain of control or ownership.
- 2.33.6 An Agent is a person employed to do any act for another, or to represent another in dealings with third person.
- 2.33.7 The successful bidder shall not be allowed to sub-contract works to any contractor from a country which shares a land border with India unless such contractor is registered with

the Competent Authority(In case of Tenders for Works contracts, including Turnkey contracts)

2.33.8 The following Certificate shall be submitted by the Bidder appending to the Technical Bid
Certificate to be filled by the Bidder:

"I have read the clause regarding restrictions on procurement from a bidder of a country which shares a land border with India; I certify that this bidder is not from such a country or, if from such a country, has been registered with the Competent Authority. I hereby certify that this bidder fulfills all requirements in this regard and is eligible to be considered. [Where applicable, evidence of valid registration by the Competent Authority shall be attached.]"

Certificate for Tenders for Works involving possibility of sub-contracting:

"I have read the clause regarding restrictions on procurement from a bidder of a country which shares a land border with India and on sub-contracting to contractors from such countries; / certify that this bidder is not from such a country or, if from such a country, has been registered with the Competent Authority and will not sub-contract any work to a contractor from such countries unless such contractor is registered with the Competent Authority. I hereby certify that this bidder fulfills all requirements in this regard and is eligible to be considered, [Where applicable, evidence of valid registration by the Competent Authority shall be attached.]"

2.34 Make in India Order

Orders issued by the Government of India regarding eligibility to participate and for purchase preference to "Local Suppliers" to encourage 'Make in India' and promote manufacturing and production of goods and services in India shall apply to this procurement, as detailed below.

2.34.1 Categories of Local Suppliers

Bidders/Contractors are divided into three categories based on Local Content. Local content in the context of this policy is the total value of the item procured (excluding net domestic indirect taxes) minus the value of imported content in the item (including all customs duties) as a proportion of the total value, in percent.

2.34.1.1 'Class-I local Supplier' with local content equal to or more than that prescribed in Tender information Summary (TIS) or 50% if not prescribed.

2.34.1.2'Class-II local Supplier' with local content equal to or more than that prescribed in TIS or 20% if not prescribed, but less than that applicable for Class-I local Supplier.

2.34.1.3'Non-Local Supplier' with local content less than that applicable for Class-II local supplier, in sub-clause above.

2.34.2 Eligibility Restrictions based on Reciprocity.

If so stipulated in the Tender Document, entities from such countries identified as not allowing Indian companies to participate in their Government procurement shall not be allowed to participate on a reciprocal basis in this tender. The term 'entity' of a country shall have the same meaning as under the FDI Policy of DPIIT as amended from time to time.

2.34.3 Eligibility to participate

- i. **Minimum local content for eligibility to participate:** Only bidders meeting the minimum prescribed local content for the product shall be eligible to participate subject to the following conditions. This threshold shall be declared in TIS and/ or Section VI: Schedule of Requirements
- ii. **Classes of Local Suppliers eligible to Participate:** Based on the Make in India Policy, classes of local/ non-local Suppliers eligible to participate in the tender shall be declared in TIS/ AITB/ Schedule of Requirements. If not so declared, only Class-I and Class-II local Suppliers shall be eligible to participate and not non-local Suppliers.

2.34.4 Thresholds

Local content for eligibility for Class-I; Class-II local Suppliers and Non-local Suppliers shall be 50% and above; 20% and above but less than 50%; and less than 20%, respectively. **Minimum local content for eligibility to participate more than 20%**, The margin of purchase preference shall be 20%.

2.34.5 Purchase preference to Class-I local Suppliers

2.34.5.1 For goods and works where the Goods are divisible by nature: NO

Among all qualified bids, the lowest bid shall be termed as L-1. If L-1 is 'Class-I local Supplier', the contract for full quantity shall be awarded to L-1. If the L-1 bid is not a 'Class-I local Supplier', 50% of the order quantity shall be awarded to L-1. After that, the lowest bidder among the 'Class-I local Supplier' whose quoted price falls within the margin of purchase preference shall be invited to match the L-1 price for the remaining 50% quantity, and a contract for that quantity shall be awarded him, subject to matching the L-1 price. In case such lowest eligible 'Class-I local Supplier' fails to match the L-1 price or accepts less than the offered quantity, the next higher 'Class-I local Supplier' within the margin of purchase preference shall be invited to match the L-1 price for the remaining quantity and so on, and the contract shall be awarded accordingly. If some quantity is still left uncovered on Class-I local Suppliers, such balance quantity shall also be ordered on the L-1 bidder.

2.34.5.2 For goods and works where the Goods are not divisible, and in the procurement of services where the bid is evaluated on price alone:

Among all qualified bids, the lowest bid shall be termed as L-1. If L-1 is 'Class-I local Supplier's the contract shall be awarded to L-1. If L-1 is not 'Class-I local Supplier', the lowest bidder among the 'Class-I local Supplier' shall be invited to match the L-1 price subject to Class-I local Supplier's quoted price falling within the margin of purchase preference, and the contract shall be awarded to such 'Class-I local Supplier' subject to matching the L-1 price. If such lowest eligible 'Class-I local Supplier' fails to match the L-1 price, the 'Class-I local Supplier' with the next higher and so on, bid within the margin of purchase preference shall be invited to match the L-1 price, and the contract shall be awarded accordingly. If none of the 'Class-I local Supplier' within the margin of purchase preference matches the L-1 price, the contract shall be awarded to the L-1 bidder.

2.34.5.3 Where parallel contracts are to be awarded to multiple bidders: In Bids where parallel contracts are to be awarded to multiple bidders subject to matching of L-1 rates or otherwise, the 'Class-I local Supplier' shall get purchase preference over 'Class-II local Supplier' as well as 'Non-local Supplier', as per following procedure:

If there is sufficient local capacity and competition for the item to be procured, as notified by the nodal Ministry, only Class I local Suppliers shall be eligible to bid. As such, the multiple Contractors, who would be awarded the contract, should be all and only 'Class I Local Suppliers'. In Bids, other than those mentioned above, 'Class II local Suppliers' or both 'Class II local Suppliers' and 'Nonlocal Suppliers' may also participate in the tender process along with 'Class I Local Suppliers'. If 'Class I Local Suppliers' qualify for the contract award for at least 50% of the tendered quantity in tender, the contract shall be awarded to all the qualified bidders as per award criteria stipulated in the Tender Documents. However, in case 'Class I Local Suppliers' do not qualify for the award of contract for at least 50% of the tendered quantity as per award criteria, purchase preference should be given to the 'Class I local Supplier' over 'Class II local Suppliers'/ 'Non-local Suppliers' provided that their quoted rate falls

within the margin of purchase preference of the highest bid considered for award of contract. To ensure that the 'Class I Local Suppliers' taken in totality are considered for award of contract for at least 50% of the tendered quantity, first purchase preference has to be given to the lowest among such eligible 'Class-I local Suppliers', subject to its meeting the prescribed criteria for the award of contract as also the constraint of the maximum quantity that can be sourced from any single Contractor. If the lowest among such 'Class-I local Suppliers' does not qualify for purchase preference because of aforesaid constraints or does not accept the offered quantity, an opportunity shall be given to next higher among such 'Class-I local Supplier', and so on.

Verification of local content and violations:

- 2.34.5.4** The 'Class-I local Supplier'/ 'Class-II local Supplier' at the time of tender, bidding, or solicitation shall be required to indicate the percentage of local content and provide self-certification that the item offered meets the local content requirement for 'Class-I local Supplier'/ 'Class-II local Supplier', as the case may be.
- 2.34.5.5** In cases of procurement for a tender value above Rs. 10 crores, the 'Class-I local Supplier'/ 'Class-II local Supplier' shall be required to provide a certificate from the statutory auditor or cost auditor of the company (in the case of companies) or a practicing cost accountant or practicing chartered accountant (in respect of Contractors other than companies) giving the percentage of local content.
- 2.34.5.6** Bids with false declarations regarding Local contents shall be rejected as **non-** responsive, in addition to punitive actions under the MII orders and for violating the Code of Integrity as per the Tender Document.

Manufacture under license/ technology collaboration agreements with phased indigenization

- 2.34.5.7** If so, declared in TIS and/ or AITB, foreign companies shall enter into a joint venture with an Indian company to participate.
- 2.34.5.8** The Procuring Entity reserves its right, but without being under any obligation to do so, to grant exemption from meeting the stipulated local content to Bidders manufacturing indigenously a product developed abroad under a license from a foreign manufacturer (who holds intellectual property rights) under a technology collaboration agreement/ transfer of technology agreement with a precise phasing of increase in local content. Bidder must obtain such an exemption letter and submit it along with his bid to avail such an exemption.

Information to be provided by Bidders regarding Make in India policy

Bidder shall provide required self-declaration as detailed in **Form 11** – Eligibility Declarations:

- 2.34.5.9** Self-declaration of their local content (and required certificate, in case of procurements above Rs 10 Crores) and their status as Class-I/ Class-II/ Non-local Supplier and their eligibility to participate as per this clause.
- 2.34.5.10** If the Tender Document indicates countries identified as not allowing Indian companies to participate in their Government procurement, then a declaration that they are not an 'Entity' of such countries (as per criteria of the FDI Policy of DPIIT as amended from time to time) and are therefore eligible to participate in this tender.
- 2.34.5.11.** If a Bidder is claiming exemption (as obtained from relevant authorities) from meeting the stipulated local content on account of manufacturing the product in India under a license from a foreign manufacturer with the precise phasing of increase in local content, he must provide proof thereof.

Support/ Preferential Treatment to Micro & Small Enterprises (MSEs)

Policies of the Government to support Micro and Small Industries (MSEs, registered as per the following sub-clause) in comparison to non-MSE enterprises shall apply to this procurement.

2.34.6 Registration of MSEs

2.34.6.1 MSEs interested in availing such benefits must enclose in Form 11 with their offer the Udhyan Registration Certificate with the Udhyan Registration Number as proof of their being MSE registered on the Udhyan Registration Portal. The certificate shall be of latest but before the deadline for the bid submission.

2.34.6.2 MSEs shall be treated as owned by SC/ ST or women entrepreneurs:

The proprietor(s) shall be SC/ ST or women In proprietary MSEs

At least 51% shares shall be held by the SC/ ST or women partners in a partnership MSEs.

At least a 51% share shall be held by SC/ ST or women promoters in Private Limited Companies MSEs.

2.34.7 Support to MSEs

a) Tender sets shall be provided free of cost to MSEs.

b) MSEs shall be exempted from payment of Earnest Money. (as per ITB-clause 9.4 below, they shall be required only to submit Bid Security Declaration)

2.34.7.1 Reservation of specific items for procurement

If so stipulated in Tender Information Summary (TIS/BDS, Appendix to NIT), this procurement is reserved as per the Public Procurement Policy for the Micro and Small Enterprises Order, 2012, for exclusive purchase from Micro and Small Enterprises (MSEs) registered with agencies, as mentioned in clause below. In such a case, only such MSEs shall be eligible to submit a bid and be considered.

2.34.8 Purchase Preference to MSEs

The Procuring Entity reserves its option to give purchase preference to MSEs compared to the non-MSE enterprises as per policies of the Government from time to time. This preference shall only apply to products produced and services rendered by Micro and Small Enterprises. If an MSE bidder quotes a price within the band of the lowest (L-1) +15 percent in a situation where the L-1 price is quoted by someone other than an MSE, the MSE bidders are eligible for being awarded up to 25 percent of the total quantity being procured if they agree to match the L-1 price. In case of more than one such eligible MSE, this 25 percent quantity shall be distributed proportionately among these bidders.

2.34.9 Support to Start-up Enterprises

Definition of Start-up Enterprises

2.34.9.1 As defined by DPIIT, an entity shall be considered as a 'Start-up':

Upto a period of ten years from the date of incorporation/ registration, if it is incorporated as a private limited company (as defined in the Companies Act, 2013) or registered as a partnership firm (registered under section 59 of the Partnership Act, 1932) or a limited liability partnership (under the Limited Liability Partnership Act, 2008) in India, and Turnover of the entity for any of the financial years since incorporation/ registration has not exceeded one hundred crore rupees, and the entity works towards innovation, development or improvement of products or processes or services or a scalable business model with a high potential for employment generation or wealth creation.

2.34.9.2 Provided that an entity formed by splitting up or reconstructing an existing business shall not be considered a 'Start-up'.

2.34.9.3 A Start-up so identified under the above definition shall be required to obtain and submit along with his bid a certificate of an eligible Start-up from the inter-Ministerial Board of Certification to obtain

support.

2.34.10 Support to Start-ups

The Government of India has ordered the following support to Start-ups (as defined by the Department of Promotion of Industrial and Internal Trade - DPIIT).

2.34.10.1 Exemption from submission of Bid Security: Such Start-ups shall be exempted from payment of Earnest Money. (as per ITB-clause ____ below, they shall be required only to submit Bid Security Declaration)

2.Relaxation in Prior Turnover and Experience: The Procuring Entity reserves its right to relax the condition of prior turnover and prior experience for start-up enterprises subject to meeting of quality & technical specifications. The decision of the Procuring Entity in this regard shall be final.

2.34.11 The Goods, Eligible Goods and Basis of Evaluation

Eligible Goods –Origin and Minimum Local Content

Unless otherwise stipulated in the Tender Document, all ‘Goods’ and ‘incidental Works/ Service’ to be supplied under the contract must conform to i) restrictions on certain countries with land-borders with India (ITB-clause ____; ii) minimum local content (Make in India Policy – ITB-clause ____). If Bidder avails benefits under any preferential policy as Class-I Local Supplier or as MSE or Start-up enterprise, the Goods must not circumvent the provisions relating to such benefits.

2.34.12 Basis of Evaluation for Schedules/ packages

- a. Unless otherwise stipulated in the TIS/ AITB, if there is more than one schedule/ package in Section VI: Schedule of Requirements, evaluation of financial ranking of bids shall be done separately for each schedule, and Bidder has the option to submit its quotation for any one or more schedules/ packages and, also, to offer special discount for combined schedules. However, Bidder shall quote for the complete Goods as stipulated in a schedule quoted.
- b. Unless otherwise stipulated in the TIS/ AITB, if there is only a list of items without grouping into schedules, evaluation of financial ranking of bids shall be done for each item separately, and Bidder has the option to submit its quotation for any one or more items and, also, to offer special discount for combined items. However, Bidder shall quote for all the destinations included in an item quoted.

2.34.13 Unless otherwise stipulated in the TIS/ AITB, if there is only one item in the Goods with several destinations, evaluation of financial ranking of bids shall be done separately for each destination included in that item separately, and Bidder has the option to submit its quotation for any one or more destinations and, also, to offer special discounts for all destinations.

ANNEXURE-1 (FORM-1)

BIDDER'S GENERAL INFORMATION

To,

THE ADDITIONAL.DIRECTOR GENERAL (E) (SZ)

AKASHVANI & DOORDARSHAN

SWAMI SIVANANDA SALAI, CHENNAI - 5

TENDER NO : ADG(E)(SZ)/PUR/NIT-06/SRMST/2023-24 Date. 14.02.24

1	Bidder Name:	
2	Number of Years in Operation	
3	Address of Registered Office	_____ City: _____ District: State: PIN/ZIP:
4A	Bidder's address where order/contract is to be placed	_____ City: _____ District:
4B	Address from where Goods/ Services are to be dispatched/ provided along with GST no. <i>(In case supply of Goods/ Services are from multiple locations, addresses and GST no. of all such locations are to be provided)</i>	City: District: State: PIN/ZIP: GST No.:

	(Indian Bidder only)	
5	Telephone Number of address where order is to be placed	<hr/> (Country Code) (Area Code) (Telephone Number)
6	E-mail address	
7	Fax Number (if available)	<hr/> (Country Code) (Area Code) (Telephone Number)
8	Website	
9	Name & Designation of Contact Person	
10	ISO Certification, if any {If yes, please furnish details}	
12	Banker's Name	
13	Branch	
14	Branch Code	
15	Bank Account Number	
16	PAN No	
17	Status of Firm	Proprietorship Firm/Partnership firm/Limited/Others If Others Specify: [Enclose relevant certificates / partnership deed/certificate of Registration, as applicable]
18	GST No. (refer Sl. No. 4B above)	[Enclose copy of GST Certificate]
19	Whether Micro or Small Enterprise? (Indian Bidder only)	Yes / No <i>(If Yes, Bidder to submit requisite documents as specified in ITB)</i>

20	Type of Entity (Indian Bidder only)	Corporate/ Non-Corporate (As per CGST/SGST/UTGST Act). (In case of Non-Corporate Entity, bidder will submit documentary evidence for same).
21	Whether Bidder is Startup or not? (Indian Bidder only)	Yes / No
22	Whether Bidder is related to any employee of Prasar Bharati? (If, yes, then the list may also be enclosed as mentioned in Para 2.30.3)	Yes / No

Place:

[Signature of Authorized Signatory of Bidder]

Date:

Name:

Designation:

Seal

ANNEXURE-2 (FORM-2)

BID SUBMISSION FORM AND AGREEMENT

To,

THE ADDITIONAL DIRECTOR GENERAL (E) (SZ)
AKASHVANI & DOORDARSHAN
SWAMI SIVANANDA SALAI, CHENNAI - 5

Sub: Design, Supply, Erection, Testing and Commissioning (DSETC) of Self Supporting Latticed Steel 75 m Tower including provisions for mountings and installation of VHF FM Antenna etc. for Akashvani FM Station at Velore, Tamilnadu – 1 No.(as per specification)- reg

TENDER NO: ADG(E)(SZ)/PUR/NIT-06/SRMST/2023-24 Date. 14.02.24

Dear Sir,

After examining / reviewing the Bidding Documents for the tender of "Including" Specifications & Scope of Work", "General Term Conditions [GTC]" and "Price Bid", etc. the receipt of which is hereby duly acknowledged, we, the undersigned, are pleased to offer to execute the whole part of the job and in conformity with the said Bid Documents, including Addenda / Corrigenda Nos. .

We confirm that this Bid is valid for a period as specified in BDS from the date of opening of "Techno-Commercial / Un-priced Bid", and it shall remain binding upon us and may be accepted by any time before the expiry of that period and any extension thereof.

If our Bid is accepted, we will provide the "Contract Performance Security / Security Deposit" equal to " 3%of the Contract Price or it is contingent based on revised OM if any at the time placing order " as mentioned in Tender Document for the due performance within "thirty [30] days" of such Award.

Until a final Agreement/Letter of Award is prepared and executed, the tender document (including addenda/ corrigenda) together with the "Notification of Award" shall constitute a binding Agreement between us.

We understand that Bidding Document is not exhaustive and any action and activity not mentioned in Bidding Documents but may be inferred to be included to meet the intend of the Bidding Documents shall be deemed to be mentioned in Bidding Documents unless otherwise specifically excluded and we confirm to perform for fulfilment of Agreement and completeness of the Work in all respects within the time frame and agreed price.

We understand that you are not bound to accept the lowest priced or any Bid that you may receive.

Place: [Signature of Authorized Signatory of Bidder]

Date: Name:

Designation:

Seal:

ANNEXURE-4 (FORM-4)

(PROFORMA OF BANK GUARANTEE FOR BID BOND)

Bank Guarantee No. _____

Ref :

THE ADDITIONAL DIRECTOR GENERAL (E)(SZ)
AKASHVANI AND DOORDARSHAN
SWAMY SIVANDA SALAI
CHENNAI – 600005

Dear Sirs,

Whereas the PRASAR BHARATI(India's Public Service Broadcaster), having its head office at O/o THE ADDITIONAL DIRECTOR GENERAL(E)(SZ) ALL INDIA RADIO AND DOORDARSHAN CHENNAI - 600005(hereinafter called the Organisation) which expression shall, unless repugnant to the context or meaning thereof, include all its successors, administrators, executors and assignees, has floated a Tender No. _____

and M/s _____ having Registered/ Head Office at _____ (Hereinafter called the "Bidder" which expression shall, unless repugnant to the context or meaning thereof, mean and include all its successors, administrators executors and assignees) have submitted a quotation Reference No. _____ and Bidder having agree to furnish as a conditions precedent for participation in tender as unconditional and irrevocable bank guarantee of Rupees _____ Only) for the due performance of Bidder/s obligations as contained in the terms of the Notice inviting Tenders (NIT) and other terms and conditions contained in the Tender Documents supplied by the Organisation specially the conditions that (a) Bidder shall keep his tender open for a period of day, i.e., from _____ to _____ or any extension thereof, and shall not withdraw or modify it in a manner not acceptable to the Organisation(b) the Bidder will execute the contract, if awarded, and shall furnish performance guarantee in the format prescribed by the Organisation within the required time. The Bidder has absolutely and unconditionally accepted these conditions. The Organisation and the Bidder have agreed that NIT/tender document is an offer made on the condition that the tender, if submitted would be kept open in its original form without variation or modification in a manner not acceptable to the Organisation for a period of _____ days, i.e., from _____ to _____ or any extension thereof and that making of the tender itself shall be regarded as an unconditional and absolute acceptance of the conditions, contained in NIT and the tender documents. They have further agreed that the contract consisting of NIT/Tender documents as the OFFER and submission of the tender as the ACCEPTANCE shall be a separate contract distinct from the contract which will come into existence when the tender is finally accepted by the Organisation. The consideration for this separate initial contract preceding the main contract is that the Organisation is not agreeable to sell the NIT/tender documents to the Bidder and

to consider the tender to be made except on the condition that the tender shall be kept open for the period indicated above and the Bidder desires to make a tender on this condition after entering into this separate initial contract with the Organisation promises to consider the tender on this condition and Bidder agrees to keep this tender open for the required period. These reciprocal promises form the CONSIDERATION for this separate initial contract between the parties.

2. Therefore, we _____ registered _____ (indicate the name of Bank) under the laws of _____ having head/registered office at _____ (hereinafter) referred to as the "Bank" which expression shall, unless repugnant to the context or meaning thereof, include all its successors,

administrators and executors hereby issue irrevocable and unconditional bank guarantee and undertake to pay immediately on first demand in writing Rupees _____ at any time immediately on such demand without any demur, reservations, recourse, contest or protest and/ or without any reference to the Bidder and any such demand made by the Organisation on the bank shall be conclusive and binding notwithstanding any difference between organisation and the Bidder or any dispute pending before any court arbitrator or any other matter whatsoever. We also agree to give that Guarantee herein the Organisation in writing. This guarantee shall not be determined/discharged/affected by the liquidation, winding up, dissolution or insolvency of the Bidder and will remain valid, binding and operative against the bank.

3. The bank also undertakes that the Organisation at the option shall be entitled to enforce this guarantee, against the Bank as a principal debtor, in the first instance, without proceeding against the Bidder.

4. The bank further agree that as between the bank and the Organisation, for purpose of the guarantee, any notice of the breach of the conditions contained in NIT and other terms and conditions contained in the Tender Documents as referred above given to the bank by the Organisation shall be conclusive and binding on Bank, without any proof, notwithstanding any other matter or difference or dispute whatsoever. We further agree that this guarantee shall not be affected by any change in our constitution, in the constitution of the Organisation or that of the Bidder. We also undertake not to revoke, in any case, this Guarantee during its currency.

5. The bank agrees with the Organisation that the Organisation shall have the fullest liberty without our consent and without affecting in any manner our obligations hereunder to vary any of the terms of the tender or get extension of the validity period from time to time. We shall not be relieved from our liability by reason of any such variation or extension of the validity period or for any forbearance, act of omission and commission on the part of the Organisation or any indulgence shown by the Organisation to the said Bidder or by any such matter or thing whatsoever which under the law relating to sureties, would, but for this provision, have the effect of so relieving us.

6. Notwithstanding anything contained herein above our liability under this Guarantee is limited to Rupees (_____ only) in aggregate and it shall remain in full force upto and including 45 days after _____ unless extended further (indicate the last date of validity period) from time to time, for such period as may be instructed in writing by M/s _____ on whose behalf this guarantee has been given, in which case, it shall remain in full force upto and including 45 days after the expiry of extended period. Any claim under this guarantee must be received by us before the expiry of 45 days from _____ or (indicate the last date of validity period) before the expiry of 45 days after the expiry of extended period, if any, if no such claim has been received by us within 45 days after the said date/extended date, the rights of the Organisation under this guarantee will cease subject to Para 8. However, if such a claim has been received by us within and upon forty five days after the said date/extended date, all rights of the organisation under this guarantee shall be valid and shall not cease until we have satisfied that claim.

7. In case contract is awarded to the Bidder here in after referred to as "Contractor" the validity of this Bank Guarantee will stand automatically extended until the contractor furnished to the Organisation a bank guarantee for Rs. _____ (in figure) (Rupees _____ only) (in words) towards performance guarantee for satisfactory performance of the contract. In case of failure to furnish performance bank Guarantee in the format prescribed by this Organisation by the required date the claim must be submitted to us within 120 days after the last date of validity period or extended period, if any. If no such claim has been received by us within 120 days after the said date/extended date, rights of the organization under this guarantee will cease. However if such a claim has been received by us within and upto 120 days after the said date/extended date all rights of the Organisation under this guarantee will cease. However, if such a claim has been received by us within and upto 120 days after the said

date/extended date, all rights of the Organisation under this guarantee shall be valid and shall not cease until we have satisfied that claim.

8.The Bank confirms that this guarantee has been issued with the approval of appropriate Exchange Control Authority in _____ and any other authority(indicate the name of the country of issue of Guarantee) if required as per the laws of the country of issue of guarantee.

The bank confirms that this guarantee has been issued with observance of the appropriate Exchange Control rules and Regulations of the country.

In witness whereof the Bank, through its authorised officer, has set its hand & stamp on this _____ day of _____ at _____ of _____ (month & year)

Signature

(Full name in capital letters)

(Designation with bank stamp)

Date.....

Witness No. 1

Signature
Full name and Address (in capital letters).....
.....
.....

Witness No. 2

Signature
Full name and Address (in capital letters).....
.....
.....

INSTRUCTIONS

(FOR FILLING UP BANK GUARANTEE FOR BID BOND)

1. **The bank guarantee should be stamped in accordance with the Stamp Act.**
2. **The non-judicial stamp paper should be in the name of the issuing bank.**
3. Clause 7 of the bank guarantee is applicable in cases of global tenders where foreign tenders also participate. When tenders are invited from parties within India, clause 7 may be deleted and replaced by clause. “The bank also agrees that courts of the place from where tenders have been invited shall have exclusive jurisdiction”.
4. Please indicate the currency in which bank guarantee is being given Rs/- have been mentioned only for illustrations. Therefore, in cases where bank guarantee is being given in a currency other than Rupees' or US Dollars' these terms may be deleted and replaced by relevant currency.
5. The period of forty five (45) days mentioned in clause 6 and one hundred twenty (120) days as given in clause 6 should be available after the expiry of the validity period of the tender or any extension thereof.
6. The bank guarantee by Indian bidder will be given from an Indian scheduled commercial bank only. The foreign bidders will give Bank Guarantee from an Indian scheduled commercial bank situated in that country. In case no Indian Bank is situated in bidder's country then Bank Guarantee from a foreign bank acceptable to the Organisation will be considered, provided it is confirmed by an Indian scheduled commercial bank and shall be governed by the Indian laws and subject to the jurisdiction of the courts in New Delhi.

ANNEXURE-5 (FORM-5)

Check List

Tender no.	ADG(E)(SZ)/PUR/NIT-06/SRMST/2023-24 Date. 14.02.24		
Specification no			
Specification for			
(COMMERCIAL)			
Group A			
Name of Bidder and Address			
GSTIN of Firm			
S.No	Description	YES / NO / NOT APPLICABLE	Remarks
1.1	Whether requisite tender Processing fee has been paid?		
2.1	Whether TDR/FDR/DD/Bank Guarantee for the requisite earnest money/Bid Bond enclosed with the offer?		
2.2	If so, furnish the following		
	I Name of the Bank		
	II Value		
	III Number		
	IV Date of issue		
	V Period of validity of the DD/FDR/ Bank Guarantee (it should not be for less than 165 days(90 days in case of DD) from the date of opening of Technical Bid)		
3	Have the rates, prices and totals etc. been checked thoroughly before signing the tender?		
4	Has a statement incorporating the Nil-deviation from the commercial terms and conditions of this Organisation has been prepared and enclosed with the offer?		
5	Whether charges for training of this Organisation's officials included in the prices? If not, whether these have been quoted separately?		
6	Whether firm FOR Destination prices have been quoted?		
8	Whether the cost of installation/erection/commissioning at site is included in the prices or not and whether it has been quoted separately?		
9	Whether the period of validity of the offer is as required in the tender document. If not, mention the extent of variation in days.		
10	Whether the offer has been signed indicating full name ?		

11	Are the pages of the tender consecutively numbered and an indication given on the front page of the tender as to how many pages are contained in the tender?		
12	Has the tender been prepared in sufficient details/clarity so as to avoid post tender clarifications/amendments?		
13	Whether required sample asked in tender has been submitted along with the offer		
14	Whether allClauses of the tender are accepted?		
15	If not, the clauses not accepted may please be indicated		
16	Whether guarantee/warranty has been furnished?		
17	Whether Commercial bid and technical bid of the tender document duly filled in and submitted.		
18	Whether each Page of Appendix- A,B, C, D, and E of the tender document is signed and submitted with the offer.		
19	Whether Integrity Pact duly signed is submitted?		
Group B			
1	Whether a copy of the latest income tax return has been enclosed?		
2	Whether details of your registration under GST have been indicated in the offer?		
Group C			
(Technical)			
1	Whether necessary literature/catalog of the full complement of equipment offered as well as operation service and maintenance manual thereof has been attached with the offer?		
2	Whether the material being offered fully conforms to all the required technical specifications (Appendix-D) ?		
3	If not, has the extent of deviation and how it is suitable to this Organization's requirement been specified.		
5	Whether the model of each equipment offered are the latest?		
6	Whether the spares support will be available for a period of 5 years from the date of supply?		
7	Do you have an after-sales service centre in India?		
	If no, which is the nearest service centre(Address).		
8	Whether complete details of after-sales service arrangements given including training for the officials of this organisation?		

ANNEXURE-6 (FORM-6)

(Technical Bid)

Sub: Design, Supply, Erection, Testing and Commissioning (DSETC) of Self Supporting Latticed Steel 75 m Tower including provisions of mountings for installation of VHF FM Antenna etc. for Akashvani FM Station at Velore, Tamilnadu – 1 No. **(as per specification)**

Tender No: ADG(E)(SZ)/PUR/NIT-06/SRMST/2023-24 Date. 14.02.24

NIL DEVIATION CERTIFICATE

Notwithstanding anything mentioned in our bid, we hereby accept all the terms and conditions of this Tender Document without any reservations whatsoever. We hereby undertake and confirm that we have understood all the specifications, stipulations, terms and conditions as mentioned in this Tender enquiry.

I hereby declare that – There is no deviation in the offer.

Signature of Authorized Signatory of Bidder

Name:

Designation:

Date:

Place:

Seal of Organization:

ANNEXURE-7 (FORM-7)

BIDDERS PAST SUPPLIES/EXPERIENCE PROFORMA					
Sl . N o.	Name & address of client	Period from	Description in detail	Total quantity supplied	Remarks

ANNEXURE-8 (FORM-8)

DECLARATION REGARDING HOLIDAY/BANNING AND LIQUIDATION, COURT RECEIVERSHIP

To

THE ADDITIONAL DIRECTOR GENERAL (E) (SZ)
AKASHVANI & DOORDARSHAN
SWAMI SIVANANDA SALAI, CHENNAI - 5

Sub: Design, Supply, Erection, Testing and Commissioning (DSETC) of Self Supporting Latticed Steel 75 m Tower including provisions of mountings for installation of VHF FM Antenna etc. for Akashvani FM Station at Vellore, Tamilnadu – 1 No.(as per specifications)

TENDER No : ADG(E)(SZ)/PUR/NIT-06/SRMST/2023-24 Date. 14.02.24

Dear Sir,

We hereby confirm that we are not on ‘Holiday’ by any offices of Prasar Bharati/ AIR/ DD/ CCW/ Government or Public Sector (due to “poor performance” or “corrupt and fraudulent practices”) or banned by Government department/ Public Sector on due date of submission of bid.

Further, we confirm that neither we nor our allied agency/(ie) (as defined in the Procedure for Action in case of Corrupt/ Fraudulent/ Collusive/ Coercive Practices) are on banning list of Government or Public Sector.

We also confirm that we are not under any liquidation, court receivership or similar proceedings or 'bankruptcy'.

In case it comes to the notice of Prasar Bharati that the bidder has given wrong declaration in this regard, the same shall be dealt as ‘fraudulent practices’ and action shall be initiated as per the Procedure for action in case of Corrupt/Fraudulent/Collusive/Coercive Practices.

Further, we also confirm that in case there is any change in status of the declaration prior to award of contract, the same will be promptly informed to Prasar Bharati by us.

Place: [Signature of Authorized Signatory of Bidder]
Date: Name:
Designation:
Seal:

LETTER OF AUTHORITY

[Proforma for Letter of Authority for Attending Pre-Bid Meetings' /'Un-priced Bid Opening' / 'Price Bid Opening'/Subsequent 'Negotiations']

Ref:

Date:

To

THE ADDITIONAL DIRECTOR GENERAL (E) (SZ)
AKASHVANI & DOORDARSHAN
SWAMI SIVANANDA SALAI, CHENNAI - 5

Sub ; Design, Supply, Erection, Testing and Commissioning (DSETC) of Self Supporting Latticed Steel 75 m Tower including provisions of mountings for installation of VHF FM Antenna etc. for Akashvani FM Station at Velore, Tamilnadu – 1 No.(as per specifications)

TENDER No : ADG(E)(SZ)/PUR/NIT-06/SRMST/2023-24 Date. 14.02.24

Dear Sir,

I/We, <_____>hereby authorize the following representative(s) for attending any 'Meetings [Pre-Bid Meeting]', 'Un- priced Bid Opening', 'Price Bid Opening' and for any subsequent 'Negotiations' correspondence / communication against the above Bidding Documents:

[1] Name & Designation Signature
[2] Phone/Cell:
Fax:
E-mail: @

[3] Name & Designation Signature
[4] Phone/Cell:
Fax:
E-mail: @

We confirm that we shall be bound by all commitments made by aforementioned authorised representative(s).

Place: [Signature of Authorized Signatory of Bidder]
Date: Name:
Designation:
Seal:

Note: This "Letter of Authority" should be on the "letterhead" of the Firm / Bidder and should be signed by a person competent and having the 'Power of Attorney' to bind the Bidder. Not more than 'two [02] persons per Bidder' are permitted to attend "Techno-commercial / Un-priced" & "Price Bid" Openings. Bidders authorized representative is required to carry a copy of this authority letter while attending the un-priced and priced bid opening, the same shall be submitted to PRASAR BHARATI.

E-Banking Mandate Form

(To be issued on Bidder letter head)

1. Bidder/customer Name:
2. Bidder /customer Address:
3. Bidders' e-mail id:
4. Particulars of bank account
 - a) Name of Bank
 - b) Name of branch
 - c) Branch code:
 - d) Address:
 - e) Telephone number:
 - f) Type of account (current/saving etc.)
 - g) Account Number:
 - h) IFSC of the bank branch
 - i) 9 digit MICR code

I/We hereby authorize Prasar Bharati to release any amount due to me/us in the bank account as mentioned above. I/We hereby declare that the particulars given above are correct and complete. If the transaction is delayed or lost because of incomplete or incorrect information, we would not hold Prasar Bharati responsible.

(Signature of Bidder/)

ANNEXURE-11 (FORM-11)

Eligibility Declaration Form'- Form- 11- to be furnished by the Bidder

Eligibility Declarations

(Ref ITB-clause _____)

(To be submitted as part of Technical bid)

(On Company Letter-head)

(Along with supporting documents, if any)

Tender Document No. Tender No./ xxxx; Tender Title:

Bidder's Name _____

[Address and Contact Details]

Bidder's Reference No. _____ Date.....

Note: The list below is indicative only. You may attach more documents as required to confirm your eligibility criteria.

Eligibility Declarations

(Please tick appropriate boxes or cross out any declaration not applicable to the Bidder)

We hereby confirm that we are comply with all the stipulation of NIT-clause __ and ITB-clause _____ and declare as under and shall provide evidence of our continued eligibility to the Procuring Entity as may be requested:

Legal Entity of Bidder: _____

1) **OEM/ Manufacturer/ Agent/ Dealership Status:** _____

2) We are/ are not a JV _____

3) We solemnly declare that we (including our affiliates or subsidiaries or constituents):

- a) are not insolvent, in receivership, bankrupt or being wound up, not have our affairs administered by a court or a judicial officer, not have our business activities suspended and are not the subject of legal proceedings for any of these reasons;
- b) (including our Contractors/ subcontractors for any part of the contract):

Do not stand declared ineligible/ blacklisted/ banned/ debarred by the Procuring Organisation or its Ministry/ Department from participation in its Tender Processes; and/ or

Are not convicted (within three years preceding the last date of bid submission) or stand declared ineligible/ suspended/ blacklisted/ banned/ debarred by appropriate agencies of Government of India from participation in Tender Processes of all of its entities, for offences mentioned in Tender Document in this regard. We have neither changed our name nor created a new "Allied Firm", consequent to the above disqualifications.

- c) Do not have any association (as bidder/ partner/ Director/ employee in any capacity) with such retired public official or near relations of such officials of Procuring Entity, as counter-indicated, in the Tender Document.
- d) We certify that we fulfil any other additional eligibility condition if prescribed in Tender Document.
- e) We have no conflict of interest, which substantially affects fair competition. The prices quoted are competitive and without adopting any unfair/ unethical/ anti-competitive means. No attempt has been

made or shall be made by us to induce any other bidder to submit or not to submit an offer to restrict competition.

4) **Restrictions on procurement from bidders from a country or countries, or a class of countries under Rule 144 (xi) of the General Financial Rules 2017:** We certify as under:

“We have read the clause regarding restrictions on procurement from a bidder of a country which shares a land border with India and on sub-contracting to contractors from such countries, and solemnly certify that we fulfil all requirements in this regard and are eligible to be considered. We certify that:

we are not from such a country or, if from such a country, we are registered with the Competent Authority (copy enclosed). and;

we shall not subcontract any work to a contractor from such countries unless such contractor is registered with the Competent Authority.

5) **MSME Status:**

Having read and understood the Public Procurement Policy for Micro and Small Enterprises (MSEs) Order, 2012 (as amended and revised till date), and solemnly declare the following:

- a) We are - Micro/ Small/ Medium Enterprise/ SSI/ Govt. Deptt. / PSU/ Others:.....
- b) We attach herewith, Udhyam Registration Certificate with the Udhyam Registration Number as proof of our being MSE registered on the Udhyam Registration Portal. The certificate is the latest up to the deadline for submission of the bid.
- c) Whether Proprietor/ Partner belongs to SC/ ST or Women category. (Please specify names and percentage of shares held by SC/ ST Partners):.....

6) **Start-up Status**

we confirm that we are/ are not a Start-up entity as per the definition of the Department of Promotion of Industrial and Internal Trade – DPIIT.

7) **Make in India Status:**

Having read and understood the Public Procurement (Preference to Make in India PPP - MII) Order, 2017 (as amended and revised till date) and related notifications from the relevant Nodal Ministry/ Department, and solemnly declare the following:

(a) Self-Certification for the category of suppliers:

(Provide a certificate from statutory auditors/ cost accountant in case of Tenders above Rs 10 Crore for Class-I or Class-II Local Suppliers). Details of local content and location(s) at which value addition is made are as follows:

Local Content and %age

Location(s) of value addition

Therefore, we certify that we qualify for the following category of the supplier (tick the appropriate category):Class-I Local Supplier/

- Class-II Local Supplier/
- Non-Local Supplier.

(b) We also declare that

- There is no country whose bidders have been notified as ineligible on a reciprocal basis under this order for an offered Goods, or
- We do not belong to any Country whose bidders are notified as ineligible on a reciprocal basis under this order for the offered Goods.

8) Self-Declaration by Indian Agents/ Associates of Foreign Principals(if applicable)

Self-attested documentary evidence about their identity (PAN, Aadhar Card, GSTIN registration, proof of address, etc.), business details (ownership pattern and documents, type of firm, year of establishment, sister concerns etc.) to establish that they are a bonafide business as per Indian Laws – are submitted as part of Form _____annexed herewith.

Agency Agreement shall be submitted with Form _____. It shall cover

the precise relationship, services to be rendered, mutual interests in business - generally and/ or specifically for the tender and any payment the agent or associate receives in India or abroad from the foreign OEM/ principal, whether a commission or a general retainer fee.

Our Foreign principals, explicitly authorizing us to make an offer in response to the tender, either directly or in association with them, are listed in Form ___ and ___ annexed herewith. That also indicates their name, address, nationality, status (i.e., whether manufacturer or agents of manufacturer holding the Letter of Authority of the Principal).

The amount of commission/ remuneration included in the price (s) quoted by Bidder for agents or associated bidder is detailed in Form _____.

Confirmation is given in Form ___annexed herewith from the foreign principals that the commission/ remuneration, reserved for Bidder in the quoted price(s), if any, shall be paid by the Procuring Entity in India, in equivalent Indian Rupees on satisfactory completion of the Project or supplies of Goods and Spares.

9) Penalties for false or misleading declarations:

We hereby confirm that the particulars given above are factually correct and nothing is concealed and undertake to advise any future changes to the above details. We understand that any wrong or misleading self-declaration would violate the Code of Integrity and attract penalties as mentioned in this Tender Document.

.....

(Signature with date)

.....

(Name and designation)

Duly authorized to sign bid for and on behalf of

.....

[name & address of Bidder and seal of company]

ANNEXURE-12 (FORM-12)

[To be executed on plain paper and submitted along with bid/tender document for tenders having a value of Rupees two crores or more.]

To be signed by the Authorized Signatories of the Bidders and Prasar Bharati

INTEGRITY PACT

This pre-bid pre-contract Agreement, hereinafter called the INTEGRITY PACT, is made on this _____ day of the month of _____, 20__.

BETWEEN

CEO Prasar Bharati (Broadcasting Corporation of India), Prasar Bharati House, Copernicus Marg, New Delhi 110001 acting through **Additional Director General (E)(SZ), All India Radio & Doordharshan Swami Sivanada Salai, Chennai -600 005**. Hereinafter called the “Buyer”, which expression shall mean and include, unless the context otherwise requires, his successors in office and assigns, on the one hand,

AND

M/s _____, at address _____ acting through Sh. _____, Chief Executive Officer, hereinafter called the “BIDDER”, which expression shall mean and include, unless the context otherwise requires, his successors in office and assigns, on the other.

PREAMBLE

WHEREAS the BUYER proposes to **DSETC of Self Supporting latticed Steel 75 m Tower including provision for mounting and installation of VHF Antenna at Akashvani FM station at Vellore, Tamilnadu**, hereinafter referred as DSETC of 75m SS Tower at Vellore, Tamilnadu and has floated a Tender Bid No. ADG(E)(SZ)/PUR/NIT-06/SRMST/2023-24 Date. 14.02.24, hereinafter referred to as the “TENDER”, and the BIDDER/ SELLER is willing to offer/ has offered the DSETC of 75m SS Tower at Vellore, Tamilnadu and the BUYER intends to award a contract / purchase order / work order for the DSETC of 75m SS Tower at Vellore, Tamilnadu covered under the TENDER hereinafter referred to the “CONTRACT”,

AND WHEREAS the BIDDER/ SELLER is a company incorporated in India under Companies Act, 1956/2013 or a Partnership registered under Indian Partnership Act, 1932 or a Limited Liability Partnership (LLP) in India or Government undertaking or a Government Autonomous body and the BUYER is an Autonomous Organisation of the Government of India performing its functions on behalf of the President of India.

AND WHEREAS the BUYER has appointed Independent External Monitors (IEMs) to monitor The TENDER process and the execution of the CONTRACT for compliance with the principles as laid down in this INTEGRITY PACT.

AND WHEREAS to meet the purpose aforesaid both the parties have agreed to enter into this INTEGRITY PACT, the terms and conditions of which shall also be read as integral part of the TENDER document and CONTRACT between the parties.

NOW, THEREFORE,

To avoid all forms of corruption by following a system i.e. fair, transparent and free from any influence / prejudiced dealing prior to, during and subsequent to the currency of the CONTRACT to be entered into with a view to:-

Enable the BUYER to obtain the DSETC SS Latticed Steel 75 m Tower at a competitive price in conformity with the defined specifications by avoiding the high cost and distortionary impact of corruption on public procurement,

And

Enable the BIDDER/ SELLER to abstain from bribing or indulging in any corrupt practices in order to secure the CONTRACT by providing assurance to the BUYER that their competitors will also abstain from bribing and other corrupt practices,

And

Enable the BUYER to prevent corruption in any form, by its officials by following transparent procedures.

The parties hereto hereby agree to enter into this INTEGRITY PACT and agree as follows:

1. Article 1 – COMMITMENTS OF THE BUYER

- 1.1 The BUYER undertakes that no official of BUYER, connected directly or indirectly with the CONTRACT/ TENDER or the BUYER personally or any of his family members will demand, take a promise for or accept, directly or through intermediaries, any bribe, consideration, gift, reward, favor or any material or immaterial benefit or any other advantage from the BIDDER/ SELLER, either for themselves or for any person, organization or third party related to the CONTRACT in exchange for an advantage in the bidding process, bid evaluation, contracting or implementation process related to the CONTRACT.

- 12 BUYER will, during the pre-contract stage, treat all BIDDERS alike, and will provide to all BIDDERS the same information and will not provide any such information to any particular BIDDER/ SELLER, which could afford an advantage to that particular BIDDER in comparison to the other BIDDERS.
- 13 The officials of the BUYER will report to the Independent External Monitor (IEM) with a copy to the Chief Vigilance Officer (CVO) any attempted or completed breaches of the above commitments as well as any substantial suspicion of such breach.
- 14 In case any such misconduct on the part of such official(s) of the BUYER is reported by the BIDDER to the BUYER with the full and verifiable facts and the same is prima facie found to be correct by the BUYER, necessary disciplinary proceedings, or any other action as deemed fit, including criminal proceedings may be initiated by the BUYER and such a person shall be debarred from further dealings related to the CONTRACT process. In such a case, while an enquiry is being conducted by the BUYER, the proceedings under the CONTRACT would not be stalled, unless considered necessary.

2. Article 2 - COMMITMENTS OF THE BIDDER

- 21 The BIDDER commits himself to take all measures necessary to prevent corrupt practices, unfair means and illegal activities during any stage of the bidding or during any pre-contract or post-contract stage in order to secure the CONTRACT or in furtherance to secure it and in particular commits himself to the following:-
 - 21.1 The BIDDER will not offer, directly or through intermediaries, any bribe, gift, consideration, reward, favor, any material or immaterial benefit or other advantage, commission, fees, brokerage or inducement to any official or family member of the BUYER, connected directly or indirectly with the Bidding Process, or to any person, organization or third party related to the CONTRACT in exchange for any advantage in the bidding, evaluation, contracting and implementation of the contract.
 - 21.2 The BIDDER further undertakes that it has not given, offered or promised to give, directly or indirectly any bribe, gift, consideration, reward, favor, any material or immaterial benefit or other advantage, commission, fees, brokerage, or inducement to any official of the BUYER or family member of the BUYER or otherwise in procuring the CONTRACT or forbearing to do or having done any act in relation to the obtaining or execution of the CONTRACT or any other CONTRACT with the PRASAR BHARATI for showing or forbearing to show favor or disfavor to any person in relation to the CONTRACT or any other CONTRACT with PRASARBHARATI.
 - 21.3 BIDDER shall disclose the name and address of his agents and representatives and the Indian BIDDERS shall disclose his foreign principals or associates, if any.

- 2.1.4 BIDDER shall disclose the payments to be made by them to agents/ brokers or any other intermediaries, in connection with this TENDER/CONTRACT.
- 2.1.5 The BIDDER further confirms and declares to the BUYER that the BIDDER is the original manufacturer/ authorised partner of the DSETC of Self Supporting latticed Steel 75m Tower at Akashvani FM station at Velore, Tamilnadu and has not engaged any individual or firm or company whether Indian or foreign other than those para 2.1.3 and para 2.1.4 above, to intercede, facilitate or in any way to recommend to the BUYER or any of its functionaries, whether officially or unofficially to the award of the CONTRACT to the BIDDER.
- 2.1.6 The BIDDER will not collude with other parties interested in the CONTRACT to impair the transparency, fairness and progress of the bidding process, bid evaluation, contracting and implementation of the CONTRACT.
- 2.1.7 The BIDDER will not accept any advantage in exchange for any corrupt practice, unfair means and illegalactivities.
- 2.1.8 The BIDDER shall not use impropriety, for purpose of competition or personal gain, or pass on to others, any information provided by BUYER as part of the business relationship, regarding plans, technical proposal and business details, including information contained in any electronic data carrier. The BIDDER also undertakes to exercise due and adequate care lest any such information isdivulged.
- 2.1.9 The BIDDER commits to refrain from giving any complaint directly or through any other manner without supporting it with full and verifiablefacts.
- 2.1.10 The BIDDER shall not instigate or cause to instigate any third person to commit any of the actions mentioned above in the sub clause of this Article2.
- 2.1.11 If the BIDDER or any employee of the BIDDER or any person acting on behalf of the BIDDER, either directly or indirectly, is a relative of any of the officers of the BUYER, or alternatively, if any relative of an official of the BUYER has financial interest/stake in the BIDDER's firm, the same shall be disclosed by the BIDDER at the time of filling of tender.
- 2.1.12 The term. Relative for this purpose would be as defined in section 2 (77) of the companies Act 2013.
- 2.1.13. The BIDDER shall not lend or borrow any money or enter into any monetary dealings or transactions, directly or indirectly, with any employee of theBUYER.

3. Article 3 - PREVIOUS TRANSGRESSION, IF ANY, OF THE BIDDER

3.1 The BIDDER declares that no previous transgression has occurred in the last three years Immediately before signing of this INTEGRITY PACT with any other company in any country in respect of any corrupt practices envisaged hereunder or with any Public Sector Enterprise in India or any Government Department in India that could justify BIDDER's exclusion from the TENDER process.

3.2 The BIDDER agrees that if it makes incorrect statement on this subject, he can be disqualified from the TENDER process or the CONTRACT, if already awarded, can be terminated for such reason.

3.3 If the BIDDER can prove that he has resorted/ recouped the damage caused by him and has installed suitable corruption prevention system, the BUYER may, at his own discretion, as per laid down organisational procedures, revoke the exclusion prematurely.

4. Article 4 - SANCTIONS FOR VIOLATIONS

4.1 Any breach of the aforesaid provisions by the BIDDER or any one employed by it or acting on its behalf (whether with or without the knowledge of the BIDDER) shall entitle the BUYER to take all or any one of the following actions, wherever required:-

4.1.1 To immediately call off the pre-contract negotiations without assigning any reason or giving any compensation to the BIDDER. However, the proceedings with the other BIDDER(S) would continue.

4.1.2 The Earnest Money Deposit (in pre-contract stage) and/or Security Deposit/ Performance Bond (after the CONTRACT is signed) shall stand forfeited either fully or partially, as decided by the BUYER and the BUYER shall not be required to assign any reason there for.

4.1.3 To immediately cancel the CONTRACT, if already signed, without giving any compensation to the BIDDER.

4.1.4 To recover all sums already paid by the BUYER, and in case of an Indian BIDDER with interest thereon at 2% higher than the prevailing Prime Lending Rate of State Bank of

India, while in case of a BIDDER from a country other than India with Interest thereon at 2% higher than the LIBOR. If any outstanding payment is due to the BIDDER from the BUYER in connection with any other CONTRACT for any other stores, such outstanding payment could also be utilized to recover the aforesaid sum and interest.

4.15 To encash the advance bank guarantee and performance bond/ warranty bond, if furnished by the BIDDER, in order to recover the payments, already made by the BUYER, along with interest.

4.16 To cancel all or any other contracts with the BIDDER. The BIDDER shall be liable to pay compensation for any loss or damage to the BUYER resulting from such cancellation/ rescission and the BUYER shall be entitled to deduct the amount so payable from the money(s) due to the BIDDER.

4.17 To debar the BIDDER from participating in future bidding processes of the Government of India/ BUYER for one to three years, which may be further extended at the discretion of the BUYER.

4.18 To recover all sums paid in violation of this INTEGRITY PACT by the BIDDER to any middlemen or agent or broker with a view to securing the CONTRACT.

4.19 In cases where irrevocable Letters of Credit have been received in respect of any contract signed by the BUYER with the BIDDER, the same shall not be opened.

4.1.10 The BUYER will be entitled to take all or any of the actions mentioned at paras 4.1.1 to 4.1.9 of this INTEGRITY PACT also on the Commission by the BIDDER or any one employed by it or acting on its behalf (whether with or without the knowledge of the BIDDER), of an offence as defined in Chapter IX of the Indian Penal code, 1860 or Prevention of Corruption Act, 1988 or any other statute enacted for prevention of corruption.

4.1.11. The decision of BUYER to the effect that a breach of the provisions of this INTEGRITY PACT has been committed by the BIDDER shall be final and conclusive on the BIDDER. However, the BIDDER can approach the IEM(s) appointed for the purposes of this INTEGRITY PACT.

5. *Article 5 - INDEPENDENT MONITORS*

5.1 THE BUYER has appointed an Independent External Monitor (hereinafter referred to as "MONITOR") for this INTEGRITY PACT in consultation with the Central Vigilance Commission (Addresses and Contact details of the Monitor(s)are:

1.Smt. Meenakshi Mishra,
IA & AS (Retd)
198/1, Neb Valley, Neb sarai, IGNOU Road,
New Delhi- 110 068
Email: pcmishra @hotmail.com

2. Shri. Alope Prasad, IPS (Retd)
Email: alokewa@gmail.com

- 52 The task of the MONITOR shall be to review independently and objectively, whether and to what extent the parties comply with the obligations under this IntegrityPact.
- 53 The MONITOR shall not be subject to instructions by the representatives of the parties and shall perform his functions neutrally and independently. He will report his findings to Chief Executive Officer, Prasar Bharati (CEO,PB).
- 54 Both the Parties accept that the MONITOR has the right to access, without restriction, all the documents relating to the Project/ procurement, including minutes of meetings.
- 55 The BIDDER accepts that the MONITOR has the right to access, without restriction, all Project documentation of the BUYER including that provided by the BIDDER. The BIDDER will also grant the MONITOR, upon his request and demonstration of a valid interest, unrestricted and unconditional access to his Project documentation. The same is applicable to Subcontractors of the BIDDER. The MONITOR shall be under contractual obligation to treat the information and documents of the BIDDER and his Subcontractor(s) with confidentiality.
- 56 The BUYER will provide to the MONITOR sufficient information about all meetings among the parties related to the Project/ procurement provided such meetings could have an impact on the contractual relations between the Parties. The Parties will offer to the MONITOR the option to participate in such meetings.
- 57 As soon as the MONITOR notices, or believe to notice, a violation of this INTEGRITY PACT, he will so inform the Authority designated by the BUYER with a copy to CVO, PB and request them to discontinue or take corrective action, or to take other relevant action. He will also separately to CEO, PB with copy to CVO, PB. The MONITOR can in this regard submit non-binding recommendations. Beyond this, the MONITOR has no right to demand from the parties that they act in a specific manner, refrain from action or tolerate action.

- 5.8 The MONITOR will submit a written report to the CVO, PB within 4 to 8 weeks from the date of reference or intimation to him by the BUYER or BIDDER and, should the occasion arise, submit proposals for correcting problematic situations.
- 5.9 If the MONITOR has reported to the CEO, PB and CVO, PB a substantial suspicion of an offence under the relevant IPC/PC Act and they have not, within reasonable time taken visible action to proceed against such offence, the MONITOR may also transmit the information directly to the Central Vigilance Commissioner.

6. *Article 6 - FACILITATION OF INVESTIGATION*

In case of any allegation of violation of any provisions of this INTEGRITY PACT or payment of commission, the BUYER or its agencies shall be entitled to examine all the documents including the Books of Accounts of the BIDDER and the BIDDER shall provide necessary information and documents in English and shall extend all possible help for the purpose of such examination.

7. *Article 7 - LAW AND PLACE OF JURISDICTION*

This Pact is subject to Indian Law. The place of performance and jurisdiction is the seat of the BUYER.

8. *Article 8 - OTHER LEGAL PROVISIONS/ ACTIONS*

- 8.1 The actions stipulated in this Integrity Pact are without prejudice to any other legal action that may follow in accordance with the provisions of the extent law in force relating to any civil or criminal proceedings.
- 8.2 Any dispute or difference arising between the parties with regard to the terms of this INTEGRITY PACT and / or, any action taken by the BUYER in accordance with this INTEGRITY PACT or interpretation thereof shall not be subject to arbitration.

83 Both the parties agree that this INTEGRITY PACT has precedence over the TENDER/ CONTRACT documents with regard to any of the provisions covered under this INTEGRITY PACT.

9. Article 9 - VALIDITY

91 The validity of this INTEGRITY PACT shall be w.e.f. the date of its signing and shall extend upto 5 (five) years or during the complete execution of the CONTRACT to the

satisfaction of both the BUYER and the BIDDER, including warranty period, whichever is later. In case BIDDER is unsuccessful at the tendering / pre-contract stage, this INTEGRITY PACT shall expire after six (06) months from the date of signing of the CONTRACT.

92 Should one or several provisions of this INTEGRITY PACT turn out to be invalid; the remainder of this Integrity Pact shall remain valid. In this case, the Parties will strive to come to an agreement to their original intentions.

93 If any claim is made/ lodged during the validity period of the INTEGRITY PACT, the same shall be binding and continue to be valid despite the lapse of INTEGRITY PACT as specified above.

94 The parties hereby sign this INTEGRITY PACT at on _____.

(For & On behalf of the Prasar Bharati)
BIDDER)

(For & On behalf of

(Office Seal)

(Office Seal)

Place:.....

Date:.....

Witness 1:

(Name & Address)

Witness 2:

(Name & Address)

ANNEXURE-13 (FORM-13)

BIDDER'S QUERIES FOR PRE BID MEETING

Sub: Design, Supply, Erection, Testing and Commissioning (DSETC) of Self Supporting Latticed Steel 75 m Tower including provisions for mountings and installation of VHF FM Antenna etc. for Akashvani FM Station at Vellore, Tamilnadu – 1 No.(as per specifications).

TENDER No: ADG(E)(SZ)PUR/NIT-06/SRMST/2023-24 Date:14.2.2024

SL. NO.	REFERENCE OF BIDDING DOCUMENT				BIDDER'S QUERY	For the Use of Office.
	SEC. NO.	Page No.	Clause No.	Subject		

NOTE: The Pre-Bid Queries may be sent by e-mail before due date for receipt of Bidder's queries.

The Address / Email / to **Send Queries :adgszpurchase@prasarbharati.gov.in**

SIGNATURE OF BIDDER:

NAME OF BIDDER :

ANNEXURE-14 (FORM-14)

(PROFORMA FOR BANK GUARANTEE FOR PERFORMANCE SECURITY)

(To be stamped in Accordance with Indian stamp Act)

The Non-judicial stamp paper should be in the name of issuing Bank

RefBank Guarantee No.
.....

To
THE ADDITIONAL DIRECTOR GENERAL(E) (SZ)
AKASHVANI AND DOORDARSHAN
CHENNAI – 600005

Dear Sirs,
In consideration of PRASAR BHARATI ((India’s Public Service Broadcaster), O/o The
Additional Director General (E) (SZ) All India Radio and Doordashan Chennai - 600005

1 (herewith referred to as the Organisation which expression shall, unless repugnant to the context or meaning thereof, include all its successors, administrators, executors and assignees and having entered into a contract dated (hereinafter called "the contract" which expression shall include all the amendments thereto) on behalf of the PRASAR BHARATI with M/s _____ having its Head/ Registered office at _____ (hereinafter referred to the contractor which expression unless repugnant to the context having been executors and assigns) and the contract having been unequivocally been accepted by the contractor resulting in a contract bearing No. _____ dated _____ valued at Rs. _____ (Rupees _____) (in words) for having agreed that the contractor shall furnish to the organisation Performance Guarantee for the faithful performance of the entire contract to the extent of **3%** of the of the value of the contract or it is contingent based on revision of OM if any at the time of placing order Rupees _____ (in words). We _____ (Name of the Bank) having its registered unless repugnant to the context or meaning thereof, include all its successors, administrators, executors and assignees do hereby guarantee and undertake to pay immediately on first demand in writing, in Rupees as acceptable to the Organisation any and all moneys the extent of Rupees _____ (In words). In aggregate at any time without any demur, reservations, recourse, contest or protests and /or without any reference to the contractor. Any such demands made by the Organisation on the Bank shall be conclusive and binding notwithstanding any difference between the Organisation and contractor or any dispute pending before any court Arbitrator or any other authority. We agree that guarantee herein contained shall be irrevocable and shall continue to be enforceable till it is discharged by the Organisation in writing The Organisation shall have the fullest liberty without affecting in any way the liability of the Bank under this guarantee, from time to time to extend the time

for performance of the contract by the contractor or vary the terms of the contract. The Organisation shall have the fullest liberty without affecting this guarantee to postpone from time to time the exercise of power vested in them or of any right which they might at anytime in any manner, and either to enforce, or to forebear to enforce, any covenants contained or implied in the contract between the Organisation and the contractor or any other course or remedy or security available to the Organisation. The Bank shall not be released of its obligations under these presents by any exercise by the Organisation of its liberty with reference to matter aforesaid or any of them or by reason of any other act of forbearance or other acts of omission or commission on the part of the Organisation or any other indulgence shown by the Organisation or by any other matter or thing whatsoever, which under law would, but for this provision, have the effect of relieving the Bank.

- 2 The Bank also agrees that the Organisation at its option, shall be entitled to enforce this Guarantee against the Bank as a principal debtor, in the first instance, without proceeding against the contractor and notwithstanding any security or other guarantee that the Organisation may have in relation to the contractors liabilities.
- 3 The Bank further agrees that the Guarantee herein contained shall remain in full force during the period that is taken for the performance of the contract i.e. complete delivery of the material/equipment as the same is a condition of supply contract and all the dues of the Organisation under or by virtue of this contract, have been fully paid and its claim satisfied or discharged or till the Organisation discharge this guarantee in writing.
- 4 We further agree that as between us and the Organisation for the purpose of this guarantee any notice given to us by the Organisation that the money is payable by the contractor and any amount claimed in such notice by the Organisation shall be conclusive and binding on us notwithstanding any difference between the Organisation and the contractor or any dispute pending before any court, Tribunal, Arbitrator or any other authority. We further agree that this Guarantee shall not be affected/discharged by any change in our constitution, in the constitutions of the Organisation that of the contractor. We also undertake not to revoke this guarantee during its currency. This guarantee shall not be determined discharged or affected by the liquidation, winding up, dissolution or insolvency of the contractor and shall remain valid, binding and operative against the Bank.
6. Notwithstanding anything contained herein above, our liability under this guarantee is limited to Rs. _____ (In figure) (Rupees _____) (In words) in aggregate and it shall remain in full force upto and including 60 days after (Indicate the date of expiry of Guarantee/Warranty period) unless extended further, from time to time, for such period as may be instructed in writing by M/s _____ on whose behalf this guarantee has been given, in which case it shall remain in full force upto the expiry of the extended period. Any claim under this guarantee must be received by us before the expiry of one year from _____ (indicate the date of expiry of Guarantee/warranty period) or before the expiry of one year after the expiry of extended period, if any. If no such claim has been received by us within one year

after the said date/extended date, the right of the Organisation under this guarantee will cease, However, if such a claim has been received by us within and up to one year after the said date/extended date, all the rights of the Organisation under this Guarantee shall be valid and shall not cease until we have satisfied that claim.

7. The bank confirms that this guarantee has been issued with the approval of the appropriate Exchange Control, Rules and regulations of the country.

We also agree that this guarantee shall be governed and construed in accordance with Indian Laws and subject to the exclusive jurisdiction of Indian courts.

The bank also agrees that Courts of New Delhi, India shall have exclusive jurisdiction.

Dated this.....day of

At

(SIGNATURE)
(Full name and address in of official capital letter)
(Designation with Bank Stamp)

Date

Witness No. 1

Signature

Full name and Address (in capital letters).....

.....

Witness No. 2

Signature

Full name and Address (in capital letters).....

.....

* Applicable where the party is foreign one.

** Applicable where the party is Indian.

3.1 INSTRUCTIONS

(FOR FILLING UP BANK GUARANTEE FOR PERFORMANCE BOND)

I. The Bank guarantee should be stamped in accordance with the stamp act.

II. The non-judicial stamp paper should be in the name of the issuing bank.

The bank also agrees that the Court of New Delhi India shall have exclusive jurisdiction.

- a. The period one year mentioned in clause 6 should be available after the expiry of the validity period/satisfactory performance, as the case may be, or any extension of such period.
- b. The Bank Guarantee by bidders will be given from any Scheduled Commercial Bank in India.
- c. In the case of guarantee by a foreign bank, the same should be got confirmed by an Indian Commercial bank.

3.(GENERAL TERMS AND CONDITIONS (GTC))

(Each page must be signed and submitted along with your offer)

3.1.1 DEFINITIONS

Unless inconsistent with or otherwise indicated by the context, following terms stipulated in this GTC shall have the meaning as defined hereunder.

3.1.2 ORDER

3.1.3 Shall mean written purchase order or acceptance of Tender(AT) issued by this organisation to the successful bidder including subsequent amendments to ORDER or AT in writing thereof.

3.1.4 THE ORGANISATION /PURCHASER

Shall mean **Additional Director General (E)(SZ), Akashvani & Doordashan, Swamy Sivananda Salai, Chennai India**, acting on behalf of the PRASAR BHARATI (India's Public Service Broadcaster), which shall include all their legal representatives, successors and assignees.

3.1.5 SUPPLIER/CONTRACTOR

Shall mean any person or persons of firm or company in India as well as abroad whose bid has been accepted by this Organisation and the legal representation, representatives, successors and permitted assignee of such person, persons, firm or company.

3.1.6 SUB-CONTRACT

Shall mean ORDER placed by the SUPPLIER/CONTRACTOR for any portion, of the ORDER or work subletted with necessary written consent of this Organisation on third party. Such subletting shall not relieve the contractor from any obligation, duty or responsibility under the Contract.

3.1.7 SUB-CONTRACTOR

Shall mean any person or persons or firm or their legal representatives, successors, assignees to whom part of ORDER has been subletted by the SUPPLIER/CONTRACTOR after necessary consent of this Organisation.

3.1.8 ORDER PRICE

Shall mean the sum accepted or the sum calculated in accordance with the rates accepted by this Organisation and amendments thereof and shall include all fees, registration and other charges paid to statutory authorities without any liability on the Organisation for any of these charges unless specially agreed to, in writing by this Organisation.

3.1.9 DELIVERY PERIOD

Shall mean receipt of the stores, erection & commissioning of the stores depending on the type of contract (Supply of Stores/Works/SITC/SETC/DSETC) by the date specified in the ORDER.

3.1.10 DESTINATION

Shall mean the location of the consignees for which this ORDER has been issued.

3.1.11 EQUIPMENTS/MATERIALS

Shall mean and include any equipment, instruments, stores and goods to be supplied for under the ORDER and amendments thereto.

3.1.12 DRAWINGS

Shall mean and include all Engineering sketches, general arrangements, layout drawing Sectional plans, and all elevations etc., related to the ORDER together with modification and revision thereto.

3.1.13 SPECIFICATIONS

Shall mean and include detailed description, statements to technical data, performance characteristic and standards (Indian as well as international as applicable and as specified in the ORDER.

3.1.14 INSPECTORS

Shall mean any person or outside Agency nominated by this Organisation to inspect equipment, materials and services, if any, in the contract stage-wise as well as final on receipt at destination as per the terms of the ORDER.

3.1.15 TESTS

shall mean such process or processes to be carried out by the SUPPLIER/CONTRACTOR as are prescribed in the ORDER considered necessary by this Organisation or their representative in order to ascertain quality, workmanship, performance and efficiency of equipment or part thereof.

3.1.16 APPROVAL

Shall mean and include the written consent either manuscript, typewritten or printed statement under or over signature or seal as the case may be of this Organisation or the representative or documents or other particulars in relation to the ORDER.

3.1.17 F.O.R./F.O.B./FAS, C&F, CIF shall mean the terms as explained in INCO terms.

3.1.18 SCOPE OF ORDER

Scope of the order shall be as defined in the ORDER, specifications, drawings and Appendices thereto.

3.2 Completeness of the EQUIPMENT shall be the responsibility of the SUPPLIER/CONTRACTOR. Any equipment, fittings and accessories, which may not be specifically mentioned in the specification or drawing (s) but which are usual or necessary for the satisfactory functioning of the EQUIPMENT (successful operation and functioning of the equipment being SUPPLIER'S/CONTRACTOR'S responsibility) shall be provided by the SUPPLIER/CONTRACTOR without any extra cost.

3.3 The SUPPLIER/CONTRACTOR shall follow the best modern practice in the manufacture of high grade EQUIPMENT notwithstanding any omission in that, the SUPPLIER/CONTRACTOR shall in all respect design, engineer, manufacture, and supply the same within delivery period to the entire satisfaction of the Organisation.

3.4 WORK TO BE CARRIED OUT UNDER THE ORDER

All equipment to be supplied and work to be carried out under the ORDER shall conform to and comply with the provision of relevant regulations/Acts (State Govt. or Central Govt.) as may be applicable to the type of equipment/work carried out and necessary certificate shall be furnished.

3.5 SPECIFICATION, DRAWING, TECHNICAL MANUALS

3.5.1 The SUPPLIER/CONTRACTOR shall furnish copies as required by this organisation and specified in the "Technical Specifications" at Appendix-D, of the technical documents, final drawing, preservation instructions, operation and maintenance manuals, test certificates, spare parts catalogue etc. before dispatch of the equipment.

3.5.2 The supplier/contractor shall be responsible for any loss to this Organisation consequent to the furnishing of the incorrect data/drawings.

3.5.3 Specifications, design and drawings issued by this Organisation to the supplier/contractor along with tender specification and ORDER are not to be sold or given on loan. These documents continue to remain property of this Organisation or their assignee and are subject to recall by this Organisation.

3.5.4 The SUPPLIER/CONTRACTOR and its employees shall not make use of the drawings, specification and technical information for any purpose any time and shall not disclose the same to any person, firm or corporate authorities without written permission of the Organisation. All such details shall be kept confidential.

3.5.5 In order to facilitate quick disposal, copies of the drawing for approval shall be sent directly and simultaneously to the authorities specified in the order in addition to the sets submitted to authority issuing order.

3.6 ACCEPTANCE OF ORDER

3.6.1 Within fifteen (15) days from date of mailing of ORDER, SUPPLIER/CONTRACTOR shall confirm acceptance of the order in its entirety.

3.6.2 The ORDER is accepted unconditionally by SUPPLIER/CONTRACTOR by returning to this Organisation copy of the ORDER duly signed, without qualification.

3.6.3 When SUPPLIER/CONTRACTOR has accepted the order with all its terms and conditions, Bidder's Bid with General sales conditions and all previous correspondence are considered superseded and void.

3.6.4 Should SUPPLIER/CONTRACTOR not respect the time limit for the confirmation of the order or in case BIDDER cannot accept the ORDER without qualifications, this Organisation reserves the right to cancel, in writing, without prejudice to other terms, the entire ORDER or part of it without notice. Under these circumstances the earnest money /bid bond given by the supplier will be forfeited in full.

3.7 MODIFICATION IN ORDER

3.7.1 All modifications leading to changes in the order with respect to technical and commercial aspects, including terms of delivery, shall be considered valid only when accepted in writing by this Organisation by issuing an amendment to the ORDER.

3.7.2 This Organization shall not be bound by any printed conditions, provision in the SUPPLIER'S BID, forms of acknowledgement of ORDER, invoice, packing list and other documents, which purport to impose any condition at variance with or supplement to ORDER.

3.8 PERFORMANCE SECURITY DEPOSIT.

3.8.1 The successful bidder, within 30 (Thirty) days of the receipt of order/letter of intent, will be required to send Security Deposit in the form of Bank Draft or in lieu thereof a Bank Guarantee from an Scheduled Indian Commercial Bank for amount as indicated in Para 1.7.1 of the "Invitation to Bid". Being a FOR destination contract, the **Security Deposit shall be 3 % of the value of the order as applicable OM issued by MOF on 30.12.2021 or it is contingent based on revision of OM if any at the time of placing order.**

3.8.2 The security money may be deposited in the form of FDR/TDR/Insurance Security Bond/ Bank guarantee in the proforma enclosed as Annexure 14

3.8.3 This Organisation shall not be liable to pay any Bank Charges, Commissions or interest on the amount of Security Deposit/Performance Bond.

3.8.4 Security Deposit, Performance Bond shall be refunded to the supplier after completion of warranty period as stipulated in the order. If the materials are supplied in the extended delivery period, the supplier will extend the validity of Bank Guarantee accordingly and the Bank Guarantee will be released after extended validity is expired.

3.8.5 For any equipment or spare parts thereof replaced during Guarantee/warranty period, it shall have further warranty for a period of **60** months from the date of acceptance as per Clause 3.9.5. The supplier will extend the validity of Bank Guarantee for a value proportionate to the value of the equipment for the period commensurate with the period of Guarantee/Warranty extension and the Bank Guarantee will be released after completion of extended warranty period subject to fulfillment of other conditions stipulated in Clause 3.9, 3.9.1 to 3.10.2 below.

**3.9 WARRANTIES AND GUARANTEES. (Kindly refer clause-1.10 of tender specification)
MATERIALS AND WORKMANSHIP(Kindly refer clause-2. 9 of tender specification)**

Unless some special Warranty/Guarantee clause has been stipulated elsewhere in the invitation to the tender or any of its Appendix, the following warranty shall form part of the contract placed on successful tender:-

1. The tenderer shall guarantee the stability, safety, durability and satisfactory mechanical behavior of the structure under specified conditions of operation, wind pressure and loading, for a period of **FIVE** years from the date of the taking over of the tower
2. In the event of structural failure or any component/part of the structure within the guarantee period specified above, the tenderer shall undertake to replace the components/parts which have failed and those which were damaged as a result thereof, free of cost and bear the expenditure to be incurred for re-erection of the tower.
3. All the Electrical/Electronic parts/materials such as AOL, Control Panels, cabling/wiring etc. shall be **Guaranteed for Five years** from the date of handing over.

3.9.1 SUPPLIER/CONTRACTOR shall fully warrant that all the stores, Equipment and components supplied under the ORDER shall be new and of first quality according to the specifications and shall be free from any defects (concealed fault, deficiency in design, materials and workmanship).

3.9.2 Should any defects be noticed in design, material and/or workmanship within 15 months from the date of shipment/dispatch of last consignment or the guarantee/warranty period as specified in specifications(Appendix-D) whichever is later, the organization shall inform Supplier/Contractor and Supplier/Contractor shall immediately on receipt of such intimation, depute their personnel within 14 days to investigate the causes of defects and arrange rectification/replacement/modification of the defective equipment at site without any cost to the Organization within a reasonable period(Maximum upto 30 days). If the Supplier/Contractor Fails to take

proper corrective action to repair/replace the defects satisfactorily within the reasonable period, this Organization shall be free to take such corrective action as may be deemed necessary at SUPPLIER'S/CONTRACTOR'S risk and cost after giving notice to the SUPPLIER/CONTRACTOR.

- 3.9.3** Damage to the machinery and/or equipment due to incomplete and erroneous instructions issued by Supplier/Contractor will be responsibility of the Supplier/Contractor and will be treated according to the provisions of warranty clause. Normal wear & tear shall not come under purview of this clause.
- 3.9.4** In case defects are of such nature that equipment shall have to be taken to Supplier's/Contractor's Works for rectification etc. Supplier/Contractor shall take the equipment at his cost after giving necessary undertaking or security as may be required by the Organisation. This Organisation shall, if so required by the Supplier/Contractor, dispatch the equipment by quickest mode on "Freight-to pay" basis to the Supplier's/ Contractor's works. After repairs, Supplier/Contractor shall deliver the equipment at site on freight prepaid basis. All risks in transit to and fro shall be borne by the Supplier/Contractor.
- 3.9.5** Equipment or spare parts thereof replaced shall have further warranty for a period of 60 months from the date of acceptance.
- 3.9.6** The Supplier/Contractor shall guarantee that they will supply spare parts if and when required on agreed price. The agreed price should include, but without any limitation to, agreed discount on the published catalogue price or on agreed percentage of profit on the landed cost.
- 3.9.7** The Supplier/Contractor will warranty that before going out of production for any of the spare parts, they will give adequate advance notice to the purchaser so that the latter may undertake to procure, if necessary, the balance of the life time requirements.
- 3.9.8** If the repairs, replacement or modification referred are of such nature as may affect the efficiency of the EQUIPMENT, this Organisation shall have the right to give to the SUPPLIER/CONTRACTOR, within one month of such replacement/renewal, notice in writing to carry out test as may be required for acceptance of the equipment.
- 3.9.9** If the Supplier/Contractor fails to honour his obligation to repair or replace defective goods within a reasonable period of time, or if Supplier/Contractor refuses to carry out work under the guarantee clause and implied guarantee condition, if danger is anticipated or in case of severe urgency, the Organisation shall be entitled to carry out, at Supplier's/Contractor's cost and risk, repair work or replacement deliveries or have it done by a third party. In case not all goods have been delivered by Supplier/Contractor, this Organisation is entitled to procure the remaining goods at Supplier's/Contractor's cost and risk. This does not relieve Supplier/Contractor of any of his guarantee obligations. Taxes and

duties of any kind whatever imposed by the authorities of the country of the supplier/contractor or his sub-contractors until delivery shall be borne by supplier.

3.10 PERFORMANCE GUARANTEE

3.10.1 SUPPLIER/CONTRACTOR shall guarantee that the performance of the EQUIPMENT/MATERIAL supplied under the order shall be strictly in conformity with specification and shall perform the duties specified under the ORDER.

3.10.2 The SUPPLIER/CONTRACTOR shall guarantee that the materials/equipment that shall be purchased from the sub-contractor(s) shall be such as to fulfill the requirements laid down vide **Para 3.9 , 3.9.1 to 3.10.1** above and shall undertake to ensure fulfillment of these requirements.

3.11 REJECTION

If the ORGANISATION finds that the goods supplied are not in accordance with the specification and other condition stated in the order or its sample (s) are received in damaged conditions (of which matters this Organisation will be the sole judge), this Organisation shall be entitled to reject the whole of the goods or the part, as the case may be, and intimate to the supplier/contractor the rejection without prejudice to the Organisation's other rights and remedies to recover from the supplier any loss which the ORGANISATION may be put to, also reserving the right to forfeit the security deposit/performance bond, if any, made for the due fulfillment of the contract. The goods shall be removed by the supplier/contractor and if not removed within 14 days of the date of communication of the rejection, the Organisation will be entitled to dispose-off the same on account and at the risk of the supplier/contractor and after recovering the storage charges at the rate of 5% of the value of goods of each month or part of month and loss and expense, if any caused to the Organisation, pay balance to the supplier/contractor.

3.12 FAILURE AND TERMINATION CLAUSE

Time and date of delivery shall be the essence of the contract. If the supplier/contractor fails to deliver the stores, or any installment thereof, within the period fixed for such delivery in the schedule or at any time repudiates the contract before the expiry of such periods, the Purchaser may, without prejudice to any other right or remedy available to him to recover damages for breach of the contract:-

3.12.1 Recover from the Supplier/Contractor as agreed, liquidated damages including administrative expenses and not by way of penalty, While granting an extension of the delivery period, where the delivery of stores or any installment thereof is accepted after expiry of the original delivery period, the Purchaser shall recover from the contractor, as agreed, the LD a sum equivalent to 0.5 (Half) percent of the prices of any portion of

stores delivered late, for each week or part thereof of delay. The total damages shall not exceed 10 (Ten) percent of the value of delayed goods/Units. **If the delayed supply/unit found vital for the functioning of the entire supply/unit, then the entire unit/Supply shall consider as delayed supply/ unit for the calculation of LD. The LD shall not exceed the amount stipulated in the contract. After a full period of extension, termination of the contract will be considered by the Organization.**

3.12.2 Purchase or authorize the purchase elsewhere on the account and at the risk of the supplier/contractor, of the stores not delivered/SITC/SETC/DSETC not carried out or other of a similar description (where stores/ SITC/SETC/DSETC exactly complying with the particulars are not in the opinion of the purchaser, which shall be final, readily procurable) by serving prior notice to the supplier/contractor without cancelling the contract in respect of the installment not yet due for delivery; or

3.12.3 Cancel the contract or a portion thereof by serving prior notice to the supplier/contractor and if so desired purchase or authorize the purchase of the stores not delivered /SITC/SETC/DSETC not carried out or others of a similar description (where stores not delivered/ SITC/SETC/DSETC not carried out, exactly complying with particulars are not in the opinion of the purchaser, which shall be final, readily procurable) at the risk and cost of the supplier/contractor. If the supplier/contractor had defaulted in the performance of the original contract, the purchaser shall have the right to ignore his tender for risk purchase even though the lowest. Where the contract is terminated at the risk and cost of the firm under the provisions of this clause, it shall be at the discretion of the purchaser to exercise his discretion to collect or not, the Security Deposit from the firm on whom the contract is placed, at the risk and expense of the defaulted firm.

3.12.4 Where action is taken under sub-clause 3.12.2 or sub-clause 3.12.3 above the supplier/contractor shall be liable for any loss which the purchaser may sustain on that account, provided the purchase or if there is an agreement to purchase, such agreement is made in case of failure to deliver the stores, within 6 months from the date of such failure and in case of repudiation of contract the supplier/contractor shall not be entitled to any gain on such the entire discretion of the purchaser to serve a notice of such purchase on the contractor.

3.12.5 It may further be noted that clause 3.12.1 above provides for recovery of liquidated damages on the cost of the contract price of delayed supplies at the rate of 1/2% (Half Percent) of the contract price of the delayed unit or effective delay occurred unit (even if it has been supplied) for per week for such delay or part thereof upto a ceiling of 10% of the contract price of delayed supplies/SITC/SETC/DSETC **If the delayed supply/unit found vital for the functioning of the entire supply/unit, then the entire unit/Supply shall consider as delayed supply/ unit for the calculation of LD.** Liquidated damages for delay in supplies/SITC/SETC/DSETC thus accrued will be recovered by the Paying Authority on instruction as

specified in the supply order, from the bill for payment of the cost of material/works submitted by the contractor in accordance with terms of supply order on instruction from Purchaser regarding liquidated damages amount.

- 3.12.6** Notwithstanding anything stated above, equipment and materials will be deemed to have been delivered/SITC/SETC/DSETC will be deemed to have been carried out only when all its components/parts are also delivered. If certain components of stores are not delivered in time/SITC/SETC/DSETC not carried out in time, the stores/SITC/SETC/DSETC will be considered as delayed until such time all the missing parts are also delivered.

3.13 INSPECTING/TESTING OF MATERIAL

The inspection of material will be carried out by the authority specified in the purchase order. The material will be accepted only after the same has been found satisfactory after inspection and duly marked and sealed by the Inspection Authority.

- 3.13.1** The supplier/contractor shall ensure that the material to be supplied against this order shall be individually inspected, tested and analysed in terms of the specifications attached to the tender and the relevant codes and practices specified therein by expression or implication. Necessary test reports shall be provided as required.
- 3.13.2** The supplier/contractor should make available to the Organisation and any other individual/agency authorised by the Organization for the purpose of inspection all its records and results in respect of inspection , test and analysis conducted by it as part of their manufacturing and testing operation under the applicable codes and practices specified by expression or implication in the tender.
- 3.13.3** Inspection tests and analysis shall be carried out/conducted at the supplier's/contractor's works by the authorised representative of the Organisation and the cost of such inspection tests and analysis including the cost of to and fro air fare and accommodation and cash allowances payable shall be borne by the Organisation.
- 3.13.4** The Contractor shall provide and deliver free of charge for tests/analysis by an independent authority at any such place or places as the Organisation or its authorised inspector may reasonably require such raw material (s) used or intended to be used for the contracted work by the Contractor as the Organisation/Inspector shall consider necessary. **The cost of such tests/analysis shall be borne by the Contractor.**
- 3.13.5** This Organisation shall be entitled at all times, whether prior to, during or after the completion of inspection by itself and/or through inspectors appointed by the Organisation at the Organisation's cost, to inspect, test and/or analyses and/or to direct the Supplier/Contractor in all respect of any store(s) or materials processes used or proposed to be used in the fabrication of the

product of any of them. The said inspection, tests and analysis as far as required, is to be conducted in the presence of the inspectors. The supplier/contractor shall ensure that the inspecting personnel referred to above are given free access to all the required places and information connected with their work, besides working facilities to carry out their function.

- 3.13.6** Should the supplier/contractor fail to comply with any of the provisions aforesaid relating to inspection, testing and /analysis the Organisation shall be entitled by itself and/or through inspectors to conduct or have conducted the inspection, test and/or analysis at the risk and expense of the supplier/contractor in all respects.
- 3.13.7** No rejected raw materials shall be used for the contracted work or re-tendered for inspection and/or test except with the prior permission of concerned Inspectors.
- 3.13.8** Unless otherwise specifically authorised by the Organisation in writing, the supplier/ contractor shall not ship or dispatch for shipment under the contract entered into, any material which has not been properly inspected/tested marked and in respect of which a certificate of quality has not been issued or signed by the inspectors.
- 3.13.9** In addition to the general conditions of the inspection stated above, the supplier/ contractor shall also satisfy all the specific conditions of inspection as enumerated in the specification attached.
- 3.13.10** In addition to inspector(s) the Organisation shall be entitled to nominate, depute or designate a representative to be stationed at the supplier's/contractor's factory in order to supervise and/or coordinate operations related to the contract. In the event of there being more than one factory involved in the work entrusted to the supplier/contractor, the Organisation shall be entitled to nominate/depute or appoint such representative(s) as necessary in respect of each such factory.
- 3.13.11** The supplier/contractor shall ensure that the material to be supplied against this order shall be individually inspected, tested and analyzed in terms of the specifications attached to the tender and the relevant codes and practices specified therein by expression or implication. Necessary test reports shall be provided as required.
- 3.13.12** The posting of such a representative by the Organisation or his actions in any manner does not absolve the supplier/contractor of any liability, and/or responsibility under this contract. The representative's posting shall be treated as advisory to the Organisation.
- 3.13.13** For false calls for the cases where material is rejected on inspection, the supplier/ Contractor will bear the actual cost of inspection incurred/suffered by the Organisation.
- 3.13.14** Place of inspections specified in supply order will not be changed without written confirmation from the Purchase Authority.

3.14 SUB-STANDARD MATERIAL/REPLACEMENT OF REJECTED GOODS

3.14.1 If the Organisation finds that MATERIAL supplied are not of the correct quality or not according to specification required or otherwise not satisfactory owing to any reason of which the Organisation will be the sole judge, the Organisation will be entitled to reject materials, cancel the contract and buy its requirement in the open market at the risk and cost of supplier, reserving always to itself the right to forfeit the security deposit/performance bonds placed by the supplier for the due fulfilment of the contract.

3.14.2 Rejected goods should be removed and replaced within 14 days of the date of communication of rejection.

3.15 SUBLETTING AND ASSIGNMENT

The contractor shall not save with the previous consent in writing of the purchase Authority, sublet, transfer or assign the contract or any part thereof or interest therein or benefit or advantage thereof in any manner whatsoever, provided nevertheless that any such consent shall not relieve the contractor from any obligation, duty or responsibility under the contract.

3.16 INTER/CHANGEABILITY OF PARTS

3.16.1 If against any item it becomes necessary to supply spare parts other than specified, the supplier/contractor shall be required to give the following certificate to the purchaser before arranging supply of spare parts bearing different parts numbers. If there is any obvious typographical or clerical error in the part number and /or description of any item, the supplier/contractor will supply the correct part. The aforesaid certificate should be supplied in such cases also. The supplier will furnish this certificate in either case, to the paying authority. No formal amendment is necessary in such cases.

3.16.2 “The changed part numbers are an exact replacement of parts ordered and are suitable for and will fit in equipment/machines and the existing fittings for which they are intended without in any way affecting the efficiency and quality of performance of the equipment/machines.”

3.16.3 If however, the substitute spare part is not a bare replacement of the part originally ordered and involves a purchase of other items in addition, as would be the case when a kit is offered instead of one small item(s) forming part of the kit, the supply of the kit would be subject to the following conditions:-

3.16.3.1 The supply of the kit will be accompanied with a certificate that the manufacturer has definitely stopped supply of the spare parts but supplying only a kit.

3.16.3.2 The spares will not be supplied as kit unless prior acceptance of the same has been obtained from the purchaser.

3.16.3.3 In case the supply of the kit involves any change in the price and if so, the revised price would be stated for scrutiny and incorporation of the same in the supply order, if found acceptable.

3.17 Provided further that if any part numbers are declared by the purchaser to be unsuitable to the machines for which they have been supplied within 60 days from the date of arrival of the stores at site, the supplier/contractor will take them back at their own cost and expense.

3.18 BREAKAGE/SHORTAGE

3.18.1 Claim in respect of breakage/shortages, if any, shall be preferred on the supplier/contractor within thirty days from the date of receipt of stores at destination by Ultimate consignee which shall be replaced/made good by the supplier/contractor at his own cost.

3.18.2 All risk or loss or damage to the material shall be upon the supplier/contractor till it is delivered in accordance with the terms and conditions of the supply order.

3.19 DESIGNS, PATENTS AND ROYALTIES

If any material used or methods or processes practiced or employed in the manufacture of items to conform with the requirement of the contract is/are covered by a patent(s) in respect of which contractor is not licensed, the contractor shall before using the material, method or process, as the case may be, obtain such license(s) and pay such royalty/royalties and license fee(s) as may be necessary. The contractor shall keep the Organisation indemnified from and against any and all claims, actions demand and proceedings whatsoever brought or made against the Organisation on the basis of any patent or infringement thereof claimed or otherwise relating to and arising from any method or process employed or matter or thing done to or in connection with any work executed by the contractor. The contractor shall at their own risk and expense defend any suit for infringement of patent or like suits brought against the Organisation (whether with or without the contractor being a party thereto and shall pay damages and costs awarded in such suit and keep the Organisation indemnified from and against all consequence thereof.)

3.20 FORCE MAJEURE

3.20.1 If any time during the continuance of the contract the performance in whole or in part by the Successful Bidder shall be prevented or delayed by reason of any war, hostility acts of the public enemy, civil commotion, sabotage, fire, floods, explosions, epidemics, Quarantine restriction, strikes, lock-outs or acts of god, **(but not including negligence or wrong-doing, predictable/seasonal rain)** herein after refer to as events and provided notice of happenings of any such eventuality is given by the

successful Bidder in writing within 07 days from the date of occurrence thereof **(and it cannot be claimed ex-post facto)**, the purchaser shall by reason of such event, neither cancel this order nor shall claim for damages against the contractor in respect of such non-performance or delay in performance and delivery shall be resumed as soon as practicable after such events have come to an end or ceased to exist. However, if such event continues for a period exceeding 90 days, either party may at its option terminate the contract by giving notice to the other party.

3.20.2 If the deliveries are suspended by force majeure conditions lasting for more than 90 days, the organization have the option of cancelling this contract in whole or part at its discretion without any liability on its part of the Purchaser,

3.21 LANGUAGE/TERMINOLOGY

The supplier/contractor shall ensure the language/terminology/description of goods used in supply order/bill of lading/Invoice any other documents dispatched by the supplier is verbatim in English.

3.22 FALL CLAUSE

3.22.1 The price for the stores/services/works under the contract/Supply order by the contractor/Supplier shall in no event exceed the lowest price at which supplier/contractor or his agent/principal/dealer as the case may be, sells the stores /services/works or offers to sell stores/services/works of identical description to any persons/organizations including the purchaser or any department of the Central Govt. or any Dept. of State Govt. or any Statutory undertaking of the Central or State Govt., as the case may be, during the currency of the contract supply/work order.

3.22.2 If at any time, during the said period, the contractor/supplier or his agent/principal/ dealer as the case may be, reduce the sales price, sells or offers to sell such stores/services/works to any persons/organizations including the purchaser or any Dept. of Central Govt. of any Dept. of a State Govt. or any statutory undertaking of the Central or State Govt. as the case may be, at a price lower than the price chargeable under the contract/supply order, he shall forthwith notify such reduction or sale or offer of sale to the Purchase Authority who has issued this contract/supply order and price payable under the contract/supply order for the stores supplied/services rendered/works carried out after the date of coming into force of such reduction or sale or offer of Sale shall stand correspondingly reduced. The above stipulation will however, not apply to :-

- a) Exports by the contractor/supplier; or
- b) Sale of goods as original equipment at prices lower than the prices charged for normal replacement.

3.22.3 The contractor/supplier shall furnish the following certificate to the concerned Purchaser.

"I/We certify that there has been no reduction in sale price of the stores/services of description identical to the stores/services supplied to PRASAR BHARATI (India's Public Service Broadcaster), O/o ADG(E)(SZ), AIR and DD, Swamy Sivananda Salai , Chennai under the contract/supply order here in and such stores/services have not been offered/sold by me/us to any person organisation including the purchaser or any Dept.of Central Govt. or any Dept. of a State Govt. or any statutory Undertaking of the Central or State Govt. as the case may be upto the date of bill during the currency of the supply order contract whichever is later at a price lower than the price charged to the Organisation under the contract/supply order except for quantity of stores categories under sub-clauses (a) and (b) of sub para (3.22.2) above, details of which are as follows....."

In case, if the price charged by our firm is more, Prasar Bharati will have the right to recover the excess charged amount from the subsequent/unpaid bill of the supplier.

3.23 PACKING & MARKING

3.23.1 The Supplier shall provide such packing of the Goods as is required to prevent their damage or deterioration during transit to their final destination as indicated in the Contract. Each package shall have a detailed packing list in duplicate indicating:

- 3.23.1.1 Supply order number & date
- 3.23.1.2 Brief description of consignment
- 3.23.1.3 Name and address of the consignee.
- 3.23.1.4 Name and address of the Suppliers.
- 3.23.1.5 Item-wise nomenclature and part number and given reference with quantities to assembly drawing.
- 3.23.1.6 Tag number for all items contained in the package.
- 3.23.1.7 Gross weight and outer dimension of the package.
- 3.23.1.8 Packing list package-wise package marks and numbers
- 3.23.1.9 Any other requirement relevant to the contract

3.23.2 Another copy of the packing list shall be put in a waterproof envelope and fastened securely to the outside of the Package.

3.23.3 Shipping Of Documents:

Invoice showing value item-wise as per supply order for customs purposes, in triplicate drawn in the name of the Installation Officer/ All India Radio, No. 41, Kalinjur Main Road, Virudhampet, Vellore – 632 001 and duly manually signed by the supplier or their authorised representative.

- 3.23.3.1 Certificate of test inspection from manufacturer/supplier.
- 3.23.3.2 Certificate of recent manufacture.

3.24 INSURANCE :

3.24.1 The Successful Bidder shall insure entire tower items during transit, storage, installation, testing and commissioning until handing over the consignee against losses, damages due to fire, earthquake, war,

flood/theft etc, no claim will be admissible on this account. The Bidder shall take insurance for his men while working at the Prasar Bharati site against any accident, death, etc. Similarly equipments, instruments, tools etc. belonging to the Bidder shall be insured against damage, loss, theft etc. All the charges for such insurance shall be borne by the Bidder. Insurance documents should be submitted to consignee before commencement of work.

3.25 SHORT/DAMAGE/DEFECTIVE/NON-RECEIPT OF MATERIAL

The supplier is responsible for safe arrival of the material upto destination. In case, there find any shortage/breakage of material, the supplier will make good the deficiency at the earliest.

3.26 PROGRESS OF MANUFACTURING OF ITEMS

From the date of receipt of order the manufacturer will send a report on monthly basis to the purchase Authority about the progress on manufacturing of item(s) ordered from him. The monthly progress report will be sent on a regular basis till completion of the entire supply as per delivery date indicated in supply order.

3.27 ARBITRATION

3.27.1 If any dispute, difference, question or disagreement shall at any time, hereafter arise, between the parties hereto or the respective representatives or assignees in connection with or arising out of the contract or in respect of meaning of specification, design, drawings, estimates, schedules, Appendix(s), orders, instructions, the construction, interpretation of this agreement, application of provisions thereof or anything hereunder contained or arising hereunder or as to the rights, liabilities or duties of the said parties hereunder or any matter whatsoever incidental to this contract or otherwise concerning the works of execution or failure to execute the same whether during the progress of work or stipulated/extended periods or before or after the compilation or abandonment thereof, it shall be referred to the sole arbitration of the person appointed by the Chief Executive Officer, Prasar Bharati .

3.27.2 If an arbitrator to whom the matter is referred dies or refuses to act or resigns for any reason from the position of arbitrator, it shall be lawful for the Chief Executive Officer, Prasar Bharati to appoint another person to act as arbitrator in the manner aforesaid. Such person shall be entitled to proceed with the reference from the stage at which it was left by his predecessor if both the parties consent to Chief Executive Officer, Prasar Bharati to this effect failing which the arbitrator will be entitled to proceed de-novo.

3.27.3 It is a further term of this contract that no person other than the person appointed by the Chief Executive Officer, Prasar Bharati as aforesaid shall act as arbitrator and that, if for any reason that is not possible, the matter is not to be referred to the arbitration at all.

- 3.27.4** The arbitrator(s) may from time to time, with the written consent of all the parties to the contract, enlarge the time for making and publishing the award.
- 3.27.5** It is a term of the contract that the party invoking arbitration shall specify the dispute or disputes to be referred to arbitration under the clause.
- 3.27.6** It is also the term of the contract that the contractor shall not stop the work under this contract and work shall continue as expected to continue whether the arbitration proceedings have commenced or not.
- 3.27.7** The arbitrator shall give reasoned award in respect of each dispute or difference referred to him. The award as aforesaid shall be final and binding on all the parties to the contract in accordance with the Indian law.
- 3.27.8** The Venue of the arbitration shall be at Chennai,TN.,subject to as aforesaid, the provision of the Indian Arbitration and Conciliation Act, 1996 and any statutory modifications or re-enactments thereof and rules made there under and for the time being in force shall apply to the arbitration proceedings under this clause.

3.28 COMPLAINT OF SPECIFICATIONS

- 3.28.1** The successful Bidder shall execute the whole and every part of the work in the most substantial and workman like manner both as regards materials and otherwise in every respect in strict accordance with the specifications. The contractor shall also conform exactly, fully and faithfully to the designs, drawings and instructions in writing in respect of the work.
- 3.28.2** Theseveral documents forming the Contract are to be taken as mutually explanatory of one another, detailed drawings being followed in preference to small scale drawing and figured dimensions in preference to scale and special conditions in preference to General Conditions”.
- 3.28.3** In the case of discrepancy between the schedule of Quantities, the Specifications and/ or the Drawings, the following order of preference shall be observed: -
- 3.28.3.1 Description of Schedule of Quantities.
 - 3.28.3.2 Particular Specification and Special Condition, if any.
 - 3.28.3.3 Drawings.
 - 3.28.3.4 AIR/DD Specifications.
 - 3.28.3.5 Indian Standard Specifications of B.I.S.
- 3.28.4** If there are varying or conflicting provisions made in any one document forming part of the contract, the Accepting Authority shall be the deciding authority with regard to the intention of the document and his decision shall be final and binding on the contractor.

3.28.5 Any error in description, quantity or rate in Schedule of Quantities or any omission therefrom shall not vitiate the Contract or release the Contractor from the execution of the whole or any part of the works comprised therein according to drawings and specifications or from any of his obligations under the contract

3.29 .COMPLIANCE TO MINIMUM WAGE ACT

The Bidder shall comply with all the provisions of the Minimum Wages Act, 1948, and Contract Labour (Regulation and Abolition) Act, 1970, amended from time to time and rules framed thereunder and other labour laws affecting contract labour that may be brought into force from time to time.

3.30 *APPLICABLE LAW

~~This contract, including all matters connected with this contract, shall be governed by the Indian laws, both substantive and procedural, for the time being in force and shall be subject to the exclusive jurisdiction of Indian Courts.~~

* **To be included in an international contract.**

3.31 INTEGRITY PACT (Applicable for the Tender more than 2 Crores)

3.31.1 Signing of Integrity Pact (IP) is mandatory for every Bidder participating in this Bid(Tender value more than 2 Cr). A copy of the IP is enclosed (Form-12), which may be deemed to have been signed by Prasar Bharati. The Bidder(s) and Prasar Bharati shall be bound by the provisions of IP in case any complaint relating to the tender is found substantiated. **The IP shall be executed on a plain paper and duly signed on each page by the same signatory who signs the bid document. Any bid not accompanied by duly signed IP by the Bidder would be rejected.** Prasar Bharati has appointed the Independent External Monitor (IEM) nominated by Central Vigilance Commission (CVC). Contact detail of IEM is given in Form -12. Any tender related complaint, for tenders covered under Integrity Pact having value of Rs.2 (Two) crore and above, may be addressed to the Independent External Monitor (IEM).

3.31.2 VIOLATIONS & CONSEQUENCES:

3.31.2.1 If a Bidder commits a violation of its Commitments and Obligations under the Integrity Pact Programme during bidding process, their entire Earnest Money Deposit/ Bid Security, would be forfeited and in addition, they would be banned from the Prasar Bharati business in future.

3.31.2.2 In case of violation of the Integrity pact by Bidder after award of the Contract, Prasar Bharati shall be entitled to terminate the Contract. Further, Prasar Bharati would forfeit the security deposits/ Contract Performance Bank Guarantee. In case it is found that the Bidder has made any frivolous, untrue and misleading allegations against Prasar Bharati or its associates, Prasar Bharati reserves its right to initiate criminal proceedings against the violating Bidder and may also impose exemplary cost for the same

APPENDIX-C

4 BID EVALUATION CRITERIA

	SALIENT FEATURES	BIDDERS CONFIRMATION
4.1.1	Open Tender No.	No. ADG(E)(SZ) PUR/NIT-06/SRMST/2023-24
4.1.2	Single Stage Two Bid System	Two Bid System
4.1.3	Tender Processing Fee	As per Para 1.2.6 of Bid Data Sheet (BDS) and Para 2.1.7 of “Instructions to Bidder”
4.1.4	Validity Period of Bid	120 days from the date of opening i.e. up to and inclusive of date of opening.
4.1.5	Bid Security	As per clause 1.2.7 of Bid Data Sheet (BDS) and Para 2.1.13 of “Invitation to Bid”.
4.1.6	Performance Security	Would be required on placement of purchase order i.e. 3% of the ordered value as applicable OM issued by MOF dated 30.12.2021 or it is contingent based on revised OM if any at the time of placing order and shall be valid beyond 60 days from the date of expiry of guarantee/warranty with claim period up to one year from the date of expiry of guarantee/warranty.
4.1.7	Delivery Period	100 days
4.1.8	Last date of submission of Bid clarification	1.3.24 @11.00 AM
4.1.9	Time & Date of Submission of Tender	11.3.24@ 14:30 Hrs
4.1.10	Opening date of technical bid	11.3.24@ 15:00 Hrs
4.1.11	Opening date of price bid	___To be Intimated latter ___
4.1.12	Evaluation Methodology	As per Para 1.20to Para 1.23 and Para 4.2

Note: -

- A. Latest updates regarding this tender can be accessed at Web-Site <https://prasarbharati.eproc.in>, <https://prasarbharati.gov.in>, and _____.

B. Pre bid conference will be held in : Akashvani FM station, Vellore

4.2. VITAL COMMERCIAL CRITERIA FOR ACCEPTANCE

4.2.1 The following vital commercial conditions should be strictly complied with failing which the bid will not be considered.

4.2.2 Bid should be from actual manufacturers, public sector undertakings, supply houses/representatives/distributors/dealers/agents authorised by the Principals.

4.2.3 After opening of the price bids, if the Lowest Bid(L-1) rate is found substantially higher than the updated cost estimate or available budget, Prasar Bharati will cancel the procurement process/ reject all Bids; re-Tender will be invited afresh after detailed scrutiny of the estimated cost.

4.2.4 If the quoted rate for Bid, is found considerably lower than the estimated rates, it will be considered as abnormally low Bid; in such cases, Prasar Bharati may seek written clarification from the Bidder, including detailed price analyses of its bid price in relation to scope, schedule, allocation of risks and responsibilities, and any other requirements of the bid's document. If, after evaluating the price analyses, Prasar Bharati determines that the bidder has substantially failed to demonstrate its capability to deliver the contract at the offered price, the Prasar Bharati may reject the bid/proposal.

4.2.5 SUBMISSION OF BID BOND/BANK GUARANTEE ALONG WITH BID

- a) In case of domestic bidders, tender must be accompanied with Earnest Money Deposit in the form of either a Bank Draft/FDR Payable to **ADG(E)(SZ), Akashvani and Doordarshan, CHENNAI** or a Bank Guarantee from an Indian Scheduled Commercial Bank with the tender document. Bank Guarantee by domestic bidders will be given on non-judicial stamp paper as per stamp duty act applicable at New Delhi.
- b) The amount of Earnest Money Deposit should be as per the Notice Inviting Tender and it shall be as per Para 1.2.7 and Para 2.21; regarding Submission of Security Deposit cum Performance Bank Guarantee for execution of contract as well as for satisfactory performance of equipment during warranty period by the successful bidders; Acceptance of Failure and Termination Clause No.3.12 of Tender document; Acceptance of Warranty and Guarantee Clause No.3.9 of Tender document; Acceptance of jurisdiction clause No. 3.27 and 3.30 of tender document.

The Bidders to quote firm prices fully in Indian currency only.

4.3 CRITERIA FOR LOADING OF BIDS

The following criteria will be adopted for evaluation of bid:-

- 4.3.1 For delivery /completion periods quoted longer than that specified in the bid document, the quoted price shall be loaded 1/2% per extra week or part thereof subject to a maximum of 5% of the quoted price. Offer with delivery/completion period longer than 10 week beyond the stipulated delivery completion period will be rejected.

4.3.2 Bidders will not indicate a separate discount. Discount if any should be merged in the rates against the quoted items. Discount, if any, indicated separately will not be taken into account for bid evaluation purposes.

4.4 VITAL TECHNICAL CRITERIA FOR ACCEPTANCE OF BIDS

4.4.1 Quotation in original must be from actual manufacturers, public sector undertakings, supply houses/representatives/distributors/dealers/agents authorised by the Principals.

4.4.2 In case the bidder is an authorised dealer/supply house, he should name the original manufacturer. Bidder should furnish a warranty to quality from the manufacturer and also furnish a certificate from the manufacturer that the bidder can quote items of the manufacturer directly. Offers not complying with these requirements will be rejected, without any notice/back reference.

4.4.3 Past performance report of similar items earlier supplied to this Organisation will be taken into consideration while evaluating this bid. The bid shall be rejected, if the past performance of the similar item earlier supplied to the Organisation is found to be unsatisfactory.

4.5 PREFERENCE TO MAKE IN INDIA

The policy of the Govt. of India to encourage “Make in India” and promote manufacturing and production of goods and services in India as per the revised “Public Procurement (Preference to Make in India), Order 2017”, circulated by the Department of Promotion of Industry and Internal trade, Ministry of Commerce & Industry, Govt. Of India vide Order No. P-45021/2/2017-PP (BE-II dated 04.06.2020 will be applicable for this tender.

4.5.1 Definitions: For the purpose of this Tender

1 ‘**Local content**’ means the amount of value added in India which shall, unless otherwise prescribed by the Nodal Ministry, be the total value of the item procured (excluding net domestic indirect taxes) minus the value of imported content in the item (including all customs duties) as a proportion of the total value, in percent.

2 ‘**Class-I local supplier**’ means a supplier or service provider, whose goods, services or works offered for procurement, has local content equal to or more than 50%, as defined under this Tender.

3 ‘**Class-II local supplier**’ means a supplier or service provider, whose goods, services or works offered for procurement, has local content more than 20% but less than 50%, as defined under this Tender.

4 ‘**Non – Local supplier**’ means a supplier or service provider, whose goods, services or works offered for procurement, has local content less than or equal to 20%, as defined under this Order.

5 ‘**L1**’ means the lowest tender or lowest bid received in response to this tender.

6 ‘Margin or purchase preference’ means the maximum extent to which the price quoted by a “Class-I local supplier” may be above the L1 for the purpose of purchase preference. For being eligible for purchase preference under this clause, the Margin of purchase preference shall be 20% (i.e. L1 + 20% band).

4.5.2 Eligibility of ‘Class-I local supplier’/ ‘Class-II local supplier’ / ‘Non-local suppliers’ for this tender:

Only ‘Class-I local supplier’ and ‘Class-II local supplier’ as defined under this tender shall be eligible to bid in procurements undertaken by procuring entities, except when global Tender enquiry has been issued, In global Tender enquiries, ‘Non-local suppliers’ shall also be eligible to bid along with ‘Class-I local supplier’ and ‘Class-II local supplier’.

4.5.3 Purchase Preference

Purchase preference shall be given to “class-I local supplier’ for the purpose of this tender in the manner specified here under.

4.5.4 For the procurement of DSETC of Self Supporting latticed Steel 75 m Tower including provisions for mountings and installation of VHF FM Antenna etc. at Akashvani FM station at Velore
The ‘Class-I local supplier’ shall get purchase preference over ‘Class-II local supplier’ as well as Non-local supplier’, as per following procedure:

- 1 Among all qualified bids, the lowest bid will be termed as L1. If L1 is ‘Class-I local supplier’, the contract for full quantity will be awarded to L1.
- 3 If L1 bid is not a ‘Class-I local supplier’, 50% of the order quantity shall be awarded to L1. Thereafter, the lowest bidder among the ‘Class-I local supplier’ will be invited to match the L1 price for the remaining 50% quantity subject to the Class-I local supplier’s quoted price falling within the margin of purchase preference, and contract for that quantity shall be awarded to such ‘Class-I local supplier’ subject to matching the L1 price. In case such lowest eligible ‘Class-I local supplier’ fails to match the L1 price or accepts less than the offered quantity, the next higher ‘Class-I local supplier’ within the margin of purchase preference shall be invited to match the L1 price for remaining quantity and so on, and contract shall be awarded accordingly. In case some quantity is still left uncovered on Class-I local suppliers, then such balance quantity may also be ordered on the L1 bidder.

4.5.5 For the procurement of DSETC of Self Supporting latticed Steel 75 m Tower including provisions for mountings and installation of VHF FM Antenna etc. at Akashvani FM station at Velore, Tamilnadu
The ‘Class-I local supplier’ shall get purchase preference over ‘Class-II local supplier’ as well as ‘Non-local supplier’ as per following procedure.

- 1 Among all qualified bids, the lowest bid will be termed as L1. If L1 is ‘Class-I local supplier’, the contract will be awarded to L1.
- 2 If L1 is not ‘Class-I local supplier’, the lowest bidder among the ‘Class-I local supplier’, will be invited to match the L1 price subject to Class-I local supplier’s quoted price falling within the margin of purchase preference, and

the contract shall be awarded to such 'Class-I local supplier' subject to matching the L1 price.

- 4 In case such lowest eligible 'Class-I local supplier' fails to match the L1 price, the 'Class-I local supplier' with the next higher bid within the margin of purchase preference shall be invited to match the L1 price and so on and contract shall be awarded accordingly. In case none of the 'Class-I local supplier' within the margin or purchase preference matches the L1 price, the contract may be awarded to the L1 bidder.

4.5.6 "Class-II local supplier" will not get purchase preference.

4.5.7 Minimum Local Content: The local content requirement to categorize a supplier as "Class-I local supplier" / "Class-II local supplier" / "Non-local supplier" shall be as defined in the Para "4.5.1" above. No change is permissible on this account.

4.5.8 Margin of Purchase Preference: The margin of purchase preference shall be 20%. For being eligible for purchase preference under this clause, the Margin of purchase preference shall be 20% (i.e. L1 + 20% band)

4.5.9 Verification of local content:

1. The 'Class-I local supplier' / "Class-II local supplier" at the time of tender, bidding or solicitation shall be required to indicate percentage of local content and provide self-certification that the item offered meets the local content requirement for 'Class-I local supplier' / "Class-II local supplier", as the case may be. They shall also give details of the location(s) at which the local value addition is made.
2. Prasar Bharati may constitute committees with internal and external experts for independent verification of self-declarations and auditor's / accountant's certificates on random basis and in the case of complaints.
3. False declarations will be in breach of the Code of Integrity under rule 175(1)(i)(h) of the General Financial Rules for which a bidder or its successors can be debarred for up to two years as per rule 151(iii) of the General Financial Rules along with such other actions as may be permissible under law.
4. A supplier who has been debarred by any procuring entity for violation of this Order shall not be eligible for preference under this tender for procurement by any other procuring entity for the duration of the debarment. The debarment for such other procuring entities shall take effect prospectively from the date on which it comes to the notice of other procurement entities.

5.0 DESCRIPTION OF STORES AND TECHNICAL SPECIFICATIONS

Specification for Design, Supply, Erection, Testing and Commissioning (DSETC) of 75M Self Supporting Lattice Steel tower including provisions of mountings for installation of VHF FM Antenna etc. for FM Stations of Akashvani.

CONTENTS

S. No.	Description	Page No.
1.	A. Essential Requirement for the tender	84-85
2.	B. Essential Eligibility Criteria for tenderer	86-87
3.	C. Payment terms	87-88
4.	Section-I, General Condition of Specification	88-96
5.	Section-II, Technical Specification	97-107
6.	Section-III, Schedule of Requirements/Materials (un-priced) for Design, Supply, Erection, Testing and Commissioning of 75 M Self Supporting Lattice Steel tower at each site	108-111
7.	Annexure-I, Draft Acceptance Test Protocol for 75 M Self Supporting Lattice Steel tower	112-113
8	List of annexure/drawings enclosed with the specification.	
	(i) Annexure-II, Suggestive tower profile(general arrangement drawing)	114
	(ii) Annexure-III, Mounting arrangement of FM Side Mount Antenna-6Bay	115
	(iii)Annexure-IV, Sketch showing deflection of the axis of tower	116
	(iv) Annexure-V, Diagram explaining Twist in tower	117
	(v) Drg. No. TM-14453/3, Details of Horizontal Cable Rack	118
	(vi) Drg. No. TM-16640, Details of Vertical Cable Rack	119
	(vii)Drg. No. TM-16597/I, A suggestive Earthing drawing	120
	(viii) Layout plan of 75 m tower at site	121

A. ESSENTIAL REQUIREMENT FOR THE TENDER:

1. (i). The tenderer should submit schedule of Requirements/Materials (un-priced) for DSETC *in the same format as given in Akashvani Specification* in the technical bid, failing which the tender shall be considered incomplete and is liable to be rejected.
 - (ii). It is also mandatory to mention Make & Model of the offered equipment in the Schedule of Requirements/Materials (un-priced) for supply, failing which the tender shall be considered incomplete and is liable to be rejected.
2. Each statement of the technical specification has to be complied with & supported by printed technical literature, technical data sheets, schematic drawings and technical manuals to assess the full merit of the offer, failing which the tender shall be considered incomplete and is liable to be rejected.
 3. The tenderer should submit the tender offer to Akashvani in the format given below, section wise & clause wise, in respect of all the sections of technical specifications. The tenderer/manufacturer of the tower must provide the page number reference of the Technical bid, in column (4) of the table given below, clearly indicating the volume number also, if any, for each supporting document to verify the parametric values shown in the technical specifications compliance statement, to assess the full merit of the offer, failing which tender shall be considered incomplete and is liable to be rejected.

S. No. of Akashvani Specification (Section wise & Clause wise) (1)	Details of Akashvani Specification (Part/ Section wise & Clause wise) (2)	Compliance (Yes/No) (3)	The Page No. of the tender offer, where the information/ supporting document is available (4)	Remarks (5)
Essential requirement for the tender				
Essential eligibility criteria for tenderer				
Section-I Clause wise				

Section-II Clause wise				
Section-III Clause wise				

4. The complete technical specification compliance statement (section wise & clause wise) along with schedule of Requirements/Materials (un-priced) as per the format given above in clause A.(3) must be signed & stamped on each page by the tenderer/ manufacturer of the tower in the tender document. The tenderer/manufacturer of the tower should mention their name in CAPITAL LETTERS, full address with pin code, phone number, fax number, e-mail address and with their full signature.

5. The complete tender shall be page numbered.

6. The Authorization and Guarantee must be given by the tenderer/manufacturer of the tower on their letter head pad duly signed & stamped on each page. The Authorization and Guarantee other than the tenderer/manufacturer of the tower in the tender will not be considered, failing which the tender shall be considered incomplete and is liable to be rejected.

7. Public Procurement (Preference to Make in India) Order No. P-45021/2/2017-B.E-II dated 15.06.2017 of Government of India, Ministry of Commerce and Industry, Department of Industrial Policy and Promotion shall be applicable.

8. Any change/modifications in Akashvani technical specifications format, language, technical parameters or of any other nature including the deletion of clause, words, lines in the technical compliance statement by the manufacturer of the tower/tenderer will not be acceptable to Akashvani and the tender is liable to be rejected.

B. ESSENTIAL ELIGIBILITY CRITERIA FOR TENDERER:

I) For Individual Tenderers:

Tenderer should meet following Work Experience and Financial capabilities:

i) Work Experience:

1.1 Bids should be from Actual Tower Erection firms. Documentary evidence to support Tower erection work like the names, addresses, Telephone Nos, E-Mail addresses, etc of the purchasers for whom towers have been designed, fabricated, supplied and erected must be provided. Copies of supply order and completion certificates issued by such purchaser should be enclosed with the tender. **This is an essential requirement.**

1.2 Tenderer should possess either A or B of the following work experience and meet any one of the three criteria given under C:

A) The Tenderer should have thorough experience in Design, fabrication, Supply, foundation, erection, testing and commissioning of AIR/DD self supporting Lattice Steel tower or RCC cum steel tower with a minimum of 40M Steel portion in past 20 years meeting any one of the following criteria:

- i) Design, SETC of minimum ONE number of similar type tower of 75 Meters high or above.
 - ii) Design, SETC of minimum TWO numbers of similar type tower of 65 Meters high or above
 - iii) Design, SETC of minimum THREE numbers of similar type tower of 60 Meters high or above.
- OR

B) The Tenderer should have thorough experience in Design, fabrication, Supply, foundation, erection, testing and commissioning of self-supporting steel lattice tower for other Government/PSU Departments/ Private Broadcaster or communication Firms in the past 7 Years and should have successfully completed these towers meeting any one of the following criteria:

- i) Design, SETC of minimum ONE number of similar type tower of 75 Meters high or above.
- ii) Design, SETC of minimum TWO numbers of similar type tower of 65 Meters high or above
- iii) Design, SETC of minimum THREE numbers of similar type tower of 60 Meters high or above.

AND

C. Any one of the following three criteria.

- i) Three similar DSETC of Tower works each costing not less than the amount equal to 40(forty) percent of the estimated cost of this tender.
- ii) Two similar DSETC of Tower works each costing not less than the amount equal to 60(sixty) percent of the estimated cost of this tender .
- iii) One similar DSETC of Tower works each costing not less than the amount equal to 80(Eighty) percent of the estimated cost of this tender, For arriving at cost of similar work being carried out, value of DSETC work executed shall be brought to current costing level by enhancing the actual value of work at simple rate of ten percent per annum calculated from the date of completion to BID opening.

i) Financial Capabilities:

Average Annual turnover of 200% of Estimated cost of the project in the last 03 Financial years OR

Cumulative Turnover of 600% of Estimated Cost of the project in last 03 Financial Years during the last 3 years

OR

Average Annual Net Worth of Minimum of 50% of estimated cost of the project in the last 03 Financial Years

OR

Cumulative Net Worth of Minimum of 150% of estimated cost of the project in the last 03 Financial Years.

II) For Joint Ventures:

- i) JV Members are jointly and severally responsible and liable in the contract. The JV should clearly state the lead partner and other partner.
- ii) JV should combinedly shall meet the Experience criteria stated under 1.2 of B (Essential eligibility criteria for tenderers) For Individual tenderers.
- iii) Regarding Financial capabilities Lead partner should have average financial turnover of at least 15% of the estimated cost of this tender, during the last 3 years ending 31st march of previous financial year.
- iv) Regarding Financial capabilities the other partner should have average financial turnover of at least 7.5% of the estimated cost of this tender, during the last 3 years ending 31st march of previous financial year.

C. PAYMENT TERMS:

Payment will be made as per following sequence in line with the progress of Erection of the Tower as per Section III- Schedule of Requirements/Materials:

- i) For Civil Foundation Work (Item at Sl no 2 under WORKS): 90% of total of cost on supply of material and works will be paid after satisfactory completion of Foundation works and submission of duly signed third party inspection certificate and inspection by authorized AIR official. Balance 10 % of the total cost on supply of material and work will be paid after satisfactory completion of SETC and handing over of the tower to AIR.
- ii) Upon Supply of Steel structure material required for construction of Tower from 0 M height to 35M height inclusive of platform at 35M height, payment will be made for 80% of this cost of Material including statutory Taxes. Payment will be made based on submission of duly signed third party inspection certificate and inspection by authorized AIR official and satisfactory receipt of material at site duly supported by the documentary proof. This is applicable for items at Sl No 1,2 and 3 under - Supply of Materials at Site.
- iii) Payment will be made for 25 % of the total erection cost including statutory tax upon successful completion of erection of tower upto 35 Mtrs height including platform at 35M

height. Payment will be made on third party inspection certificate and inspection by authorized AIR official for satisfactory completion of the stage. This is applicable for items at Sl No 3 and 5 under - Works.

iv) Upon Supply of Steel structure material required for construction of Tower from 35 M height to 50M height inclusive of platform at 50M height, payment will be made for 80% of this cost of Material including statutory Taxes. Payment will be made based on submission of duly signed third party inspection certificate and inspection by authorized AIR official and satisfactory receipt of material at site duly supported by the documentary proof. This is applicable for items at Sl No 1,2 and 4 under - Supply of Materials at Site.

v) 10% of total erection cost including statutory tax upon successful completion of erection of tower upto 50 Mtrs height including platform at 50M height will be paid on third party inspection certificate and inspection by authorized AIR official for satisfactory completion of the stage. This is applicable for items at Sl No 3 and 5 under - Works.

vi) Upon Supply of Steel structure material required for construction of Tower from 50 M height to 75M height inclusive of platform at 75M height, payment will be made for 80% of this cost of Material including statutory Taxes. Payment will be made based on submission of duly signed third party inspection certificate and inspection by authorized AIR official and satisfactory receipt of material at site duly supported by the documentary proof. This is applicable for items at Sl No 1,2 and 3 under - Supply of Materials at Site.

vii) Payment of 70% of the cost of supply of material for items SI.No.4 to 10 will be made only on completion of erection of tower upto 75M.

viii) Payment of 80% of charges of installation for items SI.No.4,6 to 14 under work will be made only on completion of erection of tower upto 75 M and satisfactory installation of these items.

ix) 15% of total erection cost including statutory tax upon successful completion of erection of tower upto 75 Mtrs height will be paid on third party inspection certificate and inspection by authorized AIR official. This is applicable for items at Sl No 3,4 and 5 under – Works

x) Rest of the payments and balance payments will be made after satisfactory competition of SETC and handing over of the tower.

xi) Payment for Insurance premium for tower , if any, will be made as per actuals on submission of respective insurance policy.

xii) All payments will be made on submission of third party certificate and inspection by authorized AIR official. Arranging third party inspection at various stages of tower as per terms of payment should be at the cost of bidder

SECTION-I

1.0 INTRODUCTION:

Akashvani requires Self Supporting Latticed Steel 75 M tower of mean probable design life of 100 years to support FM antenna etc. The tower shall be self-supporting type having square section base out of galvanized steel sections/structures of four legs. Antenna arrangements on tower are indicated in the suggestive drawing **Annexure-II** Provision for Band II 6 bay antenna aperture for FM service shall be made on the tower.

Necessary provisions in the design shall be made for mounting of the VHF Band II 4 array FM antenna in future above the Band II aperture at the top of the tower. **The mounting of VHF Band II 6 bay antenna and RF feeder cable is the present requirement. Throughout the entire aperture of band II, the outer to outer width of square cross section should be 650 mm (including splices, nuts & bolts at joints).**

- a. The tenderer shall quote for mounting of VHF Band II 6 bay FM antenna systems, feeder cables and related works/services as per details given in the subsequent paragraphs. Mounting of VHF Band II 6 bay antenna system is the present requirement. However, the tower shall be designed to take self-load and wind load for band IIFM antennae 6 & 4 bay, RF feeder cables, and Power Supply cables etc. as per the details of load at **Para No. 2.8**.

1.1 SCOPE:

These specifications aims at design, fabrication, supply, erection, testing and commissioning of 75 M Self Supporting Lattice Steel tower to support VHF FM antennae as stated above, on turnkey basis.

The broad scope of the present tender includes the following as a turnkey job:-

- a. Site visit to inspect the tower site and acquaint himself with the local terrain & site conditions, soil conditions, nature of sub soil, water table and its seasonal variations etc. and make such local enquiries, as may be necessary for any data required by him, before quoting his rates. *Otherwise, the tenderer will have to give an undertaking with the tender offer that any variation in the scope of works due to site condition shall be incorporated in the offered bid and Akashvani shall not consider any extra cost on account of that.*
- b. Soil testing from NABL approved laboratory.
- c. Preparation and submission of design documents & design drawings of Foundation and Tower structure approved by any IIT/SERC along with certificate from IIT/SERC testifying the soundness and safety of design of foundation and tower structure to Zonal ADG (E)(in hard& soft copies).
- d. Preparation and submission of general arrangement drawing(s) showing all the facilities and requirements as specified in the specification to Zonal ADG (E)(in hard & soft copies).
- e. Preparation and submission of working structural drawings and submitting to Zonal ADG (E)(in hard & soft copies).
- f. Construction of Foundation for tower.
- g. Fabrication, supply, erection, testing and commissioning of tower structure and tower appurtenances/accessories including antenna apertures, internal ladders with free fall prevention system for climbing from ground to top of the tower, platforms with railings, Vertical Cable tray& Horizontal Cable tray as per actual site conditions between transmitter building up to tower, pipe for mounting of FM Side Mount antenna etc.
- h. Painting of the tower structure& cable trays.
- i. Providing protection against lightning, earthing of tower, Aviation Obstruction Lights (AOL) including Beacon light and sun-switch. The power supply cable for multi-point power sockets at various platforms, from bottom to the topmost platform of the tower, will also be supplied by the tenderer.
- j. The cables for AOL and utility outlets at various platforms shall be taken on tower on the vertical cable rack.
- k. Hauling up of FM Side Mount antenna [6-Bay VHF FM (Pole type) Antenna]and RF Feeder cable as supplied by Akashvani.

- l. The RF feeder cable and other cables i.e. cables for AOL, power supply etc. between the transmitter building and the tower base shall be routed on a horizontal cable tray supported on G.I. Poles/Angle Iron structure which will be supplied by the tenderer. The cables on the horizontal cable tray shall be provided with G.I. sheet cover of 16 SWG to avoid any damage to RF cable due to any falling objects.
- m. Ground has to be properly leveled after erection of the tower & cleared of all debris etc.
- n. Joint inspection with representative(s) of the firm and Akashvani.
- o. Joint inspection of pending works as pointed out during joint inspection with representative(s) of the firm and Akashvani.
- p. Inspection and certification for structural firmness, verticality and all other design specifications by any IIT/SERC **after erection of tower** and submission of inspection report & certificate(s) (in hard & soft copies) to Zonal ADG (E).
- q. Handing over of tower with completion report (in soft & hard copies) including **videography & photographs** showing complete tower as well as each section of 15M length from base to top, horizontal cable tray and foundation processes starting of excavation, steel layout and reinforcements etc. to leveled finished foundation.
- r. Any other work necessary to complete the DSETC work as a turnkey job.

1.2 GENERAL:

- a. General terms and conditions of contract for SETC works including all the commercial aspects like, Packing and Packing List, Insurance and Marine Risk etc., Payment terms, Penalty/Compensation for Delay, Damages and Liabilities, Time Period and Extension for Delay, Foreclosure of Contract due to Abandonment or Reduction in Scope of Work, Cancellation of Contract in Full or Part, Recovery of Security Deposit, Performance Guarantee, Unsatisfactory Workmanship, Damages Incurred During Installation, Indian Electricity Rules, Defects, Recovery of Compensation, Ensuring Payment and Amenities, Compliance with State Labour Laws, Minimum Wages Act Compliance, Indemnifying Government against Patent Rights, Return of Surplus Material, Employment of Technical Staff and Employees, Release of Security Deposit, Safety Code etc. shall be followed by the successful tenderer as defined in the tender document in totality.
- b. *The tender shall be complete and include all minor items of work and accessories which may not have been specifically defined in this specification and schedule but which are useful and essential for the perfect assembly and completion of the tower. No extra charges will be paid for providing and installing of such items.*
- c. The successful tenderer shall make his own arrangements for power supply, water and the storage of materials and their safe custody at installation site.
- d. The successful tenderer shall make his own arrangement for employing labour-skilled and unskilled and shall make his own arrangement for providing accommodation for his labour. He should conform to all local, State laws and regulations concerning labour and their employment.
- e. The successful tenderer shall make good all damage to the purchaser's buildings, property, equipment, article etc. howsoever arising from the construction of the foundation, erection of the tower, and in the course of such work and throughout the period during which the safety of the tower is guaranteed.
- f. The successful tenderer shall indemnify and hold harmless the purchaser against all claims in respect of damages to buildings, property, articles situated nearby, not belonging to the purchaser, howsoever arising from the construction of the foundation, erection of the tower, and in the course of such work and throughout the period during which the safety of tower is guaranteed.
- g. The successful tenderer shall indemnify and hold harmless the purchaser against claims in respect of injury/any mishap to any person, howsoever arising from the construction of the foundation, erection of the tower, and in the course of such work

- and throughout the period during which the safety of the tower is guaranteed.
- h. The successful tenderer shall fully discharge all obligations under the Indian Workmen's Compensation Act, any local, State laws and regulations in so far as it affects the workmen in his employment.
 - i. The tenderer shall be responsible for safe erection of the tower and other accessories etc. The tenderer shall take all necessary safety measures and precautions during the SETC of the tower. Tower work shall be got done at site under the supervision of qualified representative(s) of the firm.
 - j. The location of the tower at the site vis-à-vis the transmitter building will be marked by Akashvanion Site Lay Out Plan. Maximum area available, including excavation work, for tower will be 20 M × 20 M.

1.3 DESIGN, CALCULATION AND DRAWINGS

- a. The tower shall be designed considering probability factor based on mean probable Design life of tower structure as 100 years.
- b. The tenderer shall obtain Wind Zones data as per IS: 875 amended to date and for seismic zone data as per IS: 1893 amended to date. The above data only shall be used in the Design Calculations. However, it may be kept in view that the wind map and seismic map are approximate only and require a judicious decision on the part of the designer to provide a good design of the tower for a design life of 100 years.
- c. It may also be ensured by the tenderer that if the site falls within a short distance from another wind zone having a higher basic wind speed, the tower shall be designed as per the higher basic wind speed.
- d. The specifications indicated herein are only to guide the tenderer about the requirements of the purchaser. Detailed design of the tower from all aspects shall be got worked out by the tenderer, keeping in view the effects of local meteorological conditions like wind velocity, seismic data, temperature, codal provisions and as per good engineering practice to ensure the safety of the tower..
- e. The design of the tower shall be based on recognized principles of structural design Engineering, conforming to latest IS codes and Standard Engineering Practices. **Full responsibility regarding soundness of design including factor of safety and the execution of work rests with the tenderer.**

For limit state of strength, partial safety factor for loads under worst atmospheric conditions and critical loadings shall be considered as a minimum 1.5 on any destabilizing load (including but not limited to, wind loads). If dead load contributes to the reduction of stresses or supports the stability for any particular action, suitable expected dead loads shall be considered.

- f. The overall force co-efficient for wind load on tower shall be taken from IS: 875 amended to date for Self-Supporting Lattice Steel Towers. For calculating the solidity ratio, actual obstruction area of tower shall be considered. Separate Wind obstructing areas shall be taken for ladder, cable rack and platforms etc.
- g. The permissible stresses in the various structural members of tower shall be adopted from the relevant clauses of IS: 800 amended to date.
- h. Loading effect of seismic forces as per IS: 1893 amended to date and cyclonic winds and conditions of frost etc., if any, is also be taken into consideration.
- i. **Loading effect due to antenna and various accessories as given at Para/clause No. 2.8 of Section-II will be taken into consideration.**
- j. The R.C.C foundation, tie beams etc, shall be designed and constructed in accordance with IS: 11233 amended to date, IS: 456 amended to date and other application codes. The minimum grade of concrete used shall be M-25.

1.4 The tenderer must furnish the following documents/information with the tender to

assess the full merit of the offer, failing which the tender shall be considered incomplete and is liable to be rejected. This is mandatory requirement.

- a. (i) The general arrangement drawing(s) showing all the facilities and requirements as specified in the specification should be attached with the offer.
(ii) Outline drawings to scale showing the assembly of the structures. These drawings should show the main dimensions including the size of main structural members, mounting centers, methods of attachment to concrete foundations and any special features of design or form.
(iii) Total weight of tower shall be given (Excluding foundation materials).
- b. Detailed information concerning design parameters such as loads due to wind effect & seismic effect, dead loads, antenna loads, combination loads considered, design philosophy along with other information which shall contain the following:
 - (i) Wind speed, terrain category, topographic factor, gust factor, risk factor etc.
 - (ii) Seismic zone factor, importance factor, response reduction factor etc.
 - (iii) Antenna loads due to VHF Band II 6 Bay (PoleType) FM Side Mount antenna, VHF Band II 4 Bay (PoleType) FM antenna at the top of tower.
 - (iv) Load combinations considered.
- c. The design calculations indicating the various formulae used for design, the bearing and shear stresses used for the design of bolted sections and the factors of safety adopted for the various structural components and materials.
For limit state of strength, partial safety factor for loads under worst atmospheric conditions and critical loadings shall be considered as a minimum 1.5 on any destabilizing load (including but not limited to, wind loads). If dead load contributes to the reduction of stresses or supports the stability for any particular action, suitable expected dead loads shall be considered.
- d. Typical design load calculation with methodology due to seismic effect.
- e. Details of Bill of Materials (BOM) showing Grade Designation and Quality of steel members, weight of the tower structure, details of fasteners, nuts, washers etc. & steel used in foundation.
- f. Design forces compression/tension due to critical load combination, design of main members panel wise i.e. leg, bracing (diagonal & horizontal) with section adopted, capacity of members based on length, slenderness ratio, allowable stress with reference & formula.
- g. Deflection at top of tower and reaction at base in most critical load combinations.
- h. The detailed design of foundations for **8.2 MT/Sq. M SBC**.
- i. Complete printed technical literature/technical data sheet/schematic drawings/detailed information of LED based Aviation Obstruction Light and details of Antenna Fixtures, Pipes, Power Supply cables, paint materials, earthing etc.
- j. Detail of activity wise Bar/PERT chart with delivery schedule.
- k. The complete technical specifications (Section wise & Clause wise) compliance statement along with Schedule of Requirements/Materials (un-priced) duly signed & stamped on each page by the tenderer/tower manufacturer as per the format given above in clause A (3) of **Essential Requirement for the Tender**.
- l. Details of past experience. **Refer clause B. Essential eligibility criteria for tenderer.**

1.5 The successful tenderer shall furnish the following documents/information within

two months after issue of acceptance of tender:

- (i) Soil testing with detailed report & document(s) (in hard & soft copies) -2 Sets
- (ii) Submission of general arrangement drawing(s) showing all the facilities and requirements as specified in the specification to Zonal ADG (E). (in hard & soft copies) -2 Sets
- (iii) Submission of design documents & design drawings of Foundation and Tower structure approved by any IIT/SERC along with certificate from IIT/SERC testifying the soundness and safety of design of foundation and tower structure to Zonal ADG (E). (in hard & soft copies) -2 Sets
- (iv) Detailed working structural drawings (in hard & soft copies) -2 Sets
- (v) Any other drawings for the completeness of the tower design as per Akashvani specification.

The following references shall be indicated in the above design documents & design drawings, working structural drawings, general arrangement drawings etc. while submitting to concerned Zonal Offices.

- (1) Akashvani AT No. (2) Akashvani Specification No. & (3) Approval of competent authority with signature & stamp.

After the acceptance of all working structural drawings by Zonal ADG (E), the successful tenderer shall send all working structural drawings to concerned Zonal ADG (E), concerned Akashvani Station(s) and Akashvani Directorate indicating all the references. All these working structural drawings as per Akashvani specifications must be available with all concerned offices before the start of the tower work at the site

1.6 PATENTS AND COPYRIGHTS:

The tenderer shall hold the purchaser and his employees safe, harmless and immune from any liability that may arise out of infringements of patents and copyrights associated with the design, fabrication, erection and use of the tower and its accessories.

1.7 DELIVERY PERIOD:

The Delivery Period shall be 100 days

1.8 INSPECTION & TESTS:

(a) Inspection will be done at various stages as follows: -

- 1. Design verification and checking of drawings before commencement of construction/fabrication.
- 2. Inspection of soil excavation at foundation stage.
- 3. Material inspection before shifting at site. (This includes reports/certificates of

different quality test from BIS /NABL approved lab(s) as mentioned below.

4. Inspection during excavation for foundation and after erection of tower.
5. Checking of Verticality tolerance etc. as per Akashvani specifications at the final stage i.e. after complete erection of tower.

(b) Test for strength of foundation: The concrete used in the foundation should be designed as per IS:10262 amended to date. Along with the foundation, cubes should be cast, which can be tested on 7 days and 28 days to get the strength of the concrete used in the tower foundation. Reinforcement used in the foundation must also be tested in a BIS/NABL approved Labs.

(c) Pre-dispatch inspection of tower material shall have to be got done by representative(s) of Akashvani in India by giving an advance notice of **TWO WEEKS**. The certifying agency IIT/SERC that will issue certification for structural safety & firmness, verticality and all other design specifications in compliance of clause 1.9 of Section-I will also be part of PDI. Pre-dispatch inspection of tower material and subsequent inspection of erected tower shall be done as per mutually accepted test procedure, which shall be submitted and got approved from Akashvani before the supply of tower material. A draft Acceptance Test Protocol as per Annexure-I is enclosed for guidance purpose. Travelling expenses for Akashvani's representative(s) will be borne by Akashvani.

d. Structural Steel:

The tenderer shall procure all structural steel members from namely SAIL, TISCO, JINDAL and RINL. Structural steel sections not available from main producers can be procured from secondary producers subject to production of proof of manufacture of structural steel members from virgin billets produced from primary steel producers before starting fabrication work. Original copies of the test certificates of steel should be made available at the time of inspection. Samples may be taken at the discretion of Akashvani and tested at BIS /NABL approved lab(s) as per provisions in this regard in the relevant IS codes, for which cost shall be borne by the tenderer. *In case the test results indicate that the Steel arranged by the tenderer does not conform to relevant IS Codes, the same shall be rejected.*

e. Fasteners:

Manufacturer's routine test certificates for bolts, nuts, washers etc. as laid down in relevant BIS code shall be submitted by the tenderer at the time of inspection. Samples may be taken at the discretion of Akashvani and tested at BIS /NABL approved lab(s) as per provisions in this regard in the relevant BIS codes, for which cost shall be borne by the tenderer. In case, the test results indicate that the Fasteners arranged by the tenderer does not conform to relevant BIS Codes, the same shall be rejected.

f. Galvanizing:

The tenderer shall prepare a detailed galvanizing procedure including Flow Chart with control parameters and all plant standards as required above and submit to Akashvani as

part of Quality Assurance Plan.

g. All standard tests, including quality control tests, in accordance with appropriate BIS standard shall be carried out unless otherwise specified herein.

h. The following test certificates should be made available at the time of inspection. All the test certificates shall be issued by BIS /NABL approved lab(s).

1. History of metallurgy and Original copies of the test certificates of steel as per the format prescribed by BIS Code.
2. Manufacturer's routine test certificates for bolts, nuts, washers etc. as laid down in relevant BIS code.
3. All standard tests, including quality control tests, in accordance with appropriate BIS standard regarding galvanizing.
4. All standard tests for welds as per BIS.

i. In addition to the provisions of clause regarding inspection, following shall also be included:

1. The tenderer shall keep Akashvani informed in advance about the time of starting and progress of manufacture and fabrication of various parts, so that it can be inspected, if required.
2. The acceptance of any part or items shall in no way relieve the tenderer of any part of his responsibility for meeting the overall requirement of the specifications.
3. Any member of the structure found not to comply with the approved drawings, shall be rejected. No member once rejected should be resubmitted for inspection except in case, where Inspecting Officer considers that the defect can be rectified.
4. All welded structures shall be subject to a non-destructive testing as per BIS code requirement and cost should be borne by the tenderer.
5. IS: 822 amended to date to be followed for inspection of welds and IS: 3600 (Part 1 to 9) amended to date to be followed for testing of welds.
6. All gauges, templates, jigs, fixtures, instruments necessary for inspection and testing shall be provided by the tenderer to Akashvanifor the purpose of inspection.
7. To ensure effective in-process quality control, it is essential that the manufacturer arrange all the testing facilitates for tests like, weight of zinc coating, tensile & shear strength, non-destructive testing of welds etc. The manufacturer should have proper quality assurance system in line with requirement of this specification.
8. Each Piece of steel work shall be distinctly marked before delivery in accordance with marking diagram and shall bear such and other marks as well to facilitate erection.
9. Each individual tower member shall carry a stamped mark (number) assigned to in the approved drawings. These stamping shall be done by a metal die of 16 mm size before galvanizing and on optimum depth so as to be clearly legible after galvanizing.

1.9 CERTIFICATION & COMPLETION REPORT AFTER ERECTION OF TOWER:

(a) After erection of tower, the tower structure shall be inspected and certified for

its structural safety &firmness, verticality and all other design specifications by any IIT/SERC. Certified inspection report with all the observations, recommendations etc. shall be submitted to Akashvani. The recommendations/suggestions will have to be incorporated by the tenderer before submitting the final completion report. All costs on this inspection and post inspection corrections, if required, for completeness of the tower shall be borne by the tenderer.The concerned IIT/SERC should be made part of PDI in order to facilitate above certification.

- (b) The tenderer is also required to submit completion report colour printed and duly bound for the reference and record of Akashvani. A soft copy of the above must also be submitted.

1.10 GUARANTEE:

- 1) The tenderer shall guarantee the stability, safety, durability and satisfactory mechanical behavior of the structure under specified conditions of operation, wind pressure and loading, for a period of **FIVE** years from the date of the taking over of the tower.
- 2) In the event of structural failure or any component/part of the structure within the guarantee period specified above, the tenderer shall undertake to replace the components/parts which have failed and those which were damaged as a result thereof, free of cost and bear the expenditure to be incurred for re-erection of the tower.
- 3) All the Electrical/Electronic parts/materials such as AOL, Control Panels, cabling/wiring etc. shall be guaranteed for **FIVE** years from the date of handing over.

SECTION-II

2.0 TECHNICAL SPECIFICATIONS:

All the BIS Specifications referred herein after shall be read with the latest amendments i.e. up to the date of submission of tender offer.

2.1 FABRICATION AND DESIGN:

2.1.1 Tower steel section:

- (i) All tower members shall be made out of structural steel conforming to IS:2062 amended to date.
- (ii) The main members in legs, bracings, horizontals etc, **shall not be less than 6mm thick.**
- (iii) The secondary members, like hand-rails, ladders, redundant setc. **shall not be less than 5mm thick.**
- (iv) In case certain steel sections are not available in the market in the designed thickness, the next higher thickness available should be used.

2.1.2 Fasteners (Bolts, nuts and washers):

- (i) The tower members and other structures shall be connected/assembled by means of bolts and nuts with spring washers or locking nut.
- (ii) The quality of bolts should conform to mechanical properties as per IS:1367 amended to date and dimension to IS:6639 amended to date.
- (iii) The bolts shall be of minimum property class 8.8 as specified in IS:1367 (Part-3) amended to date.
- (iv) Nuts shall conform to IS:1363(Part-3) and appropriate property class as specified in IS:1367(Part-6) amended to date. Nuts should be double chamfered as per the requirement of IS:1363 amended to date.
- (v) The shear, bearing & tensile strength shall be in accordance with IS:800 amended to date. The fasteners shall be procured from reputed manufacturers such as UNBRAKO, TVS SUNDRAM, NEXO, BKR etc.
- (vi) All the bolts and nuts shall be galvanized by high temperature hot-dip galvanizing in accordance with IS:1367(Part-13) amended to date.
- (vii) The bolts shall be as per IS:12427 & IS:4000 amended to date.
- (viii) The plain and spring washers shall be hot-dip galvanized as per IS:1367 (Part-13) amended to date OR electro galvanized as per IS:1573 amended to date & IS:3655 amended to date, as applicable.
- (ix) Nut Rotation from Snug Tight Condition:

Bolt length (as measured from underside of head to extreme end of point)	A bolt faces normal to bolt axis	One face normal to bolt axis & other face sloped not more than 1:20 (bevel washer not used)	Bolt faces slope not more than 1:20 from normal to bolt axis (bevel washers not used).
Upto including 4dia.	1/3turn	1/2 turn	2/3 turn
Over 4dia. but not exceeding 8dia.	1/2 turn	2/3 turn	5/6 turn
Over 8dia. but not exceeding 12dia.	2/3turn	5/6 turn	1 turn

Alternatively, nuts may be tightened using a calibrated wrench so that the proof load of the bolt specified in IS: 1367 amended to date is achieved. “Snug tight is defined as the tightness attained by a few impacts of an impact wrench or the full effort of a man using an ordinary spud wrench. Following this initial operation, bolts shall be placed in remaining holes in the connection and brought to snug tight position”.

2.1.3 Fabrication:

- (i) The fabrication of tower components shall conform to IS:800 amended to date.
- (ii) All steel sections shall be fabricated as per the approved drawings.
- (iii) Gas cutting, shearing, sawing, modification of holes, welding etc. is not permitted for finished members at the site.

2.1.4 Drilling and punching:

- (i) Holes for bolts shall be drilled or punched with jig, but drilled holes shall be preferred. Punching may be adopted for thickness up to 5 mm. Tolerances regarding punched holes are as follows.
 - a. Holes must be perfectly circular and no tolerance in this respect will be permissible.
 - b. The maximum allowable difference in diameter of the holes on the two sides of plates or angles shall be 0.8 mm i.e., the allowable tolerance in punched holes should not exceed 0.8 mm on diameter.
- (ii) Drilled & punched holes must be square with the plates or angles and have their wall parallel.
- (iii) Holes on both side of the bend line in a bent member shall be drilled after bending.
- (iv) The mild steel section up to 75×75×6 may be bent by cold process up to bend angle 10° and all other angle sections and bend angles shall be bent by hot process.
- (v) The formation of bends by the “Cut & Weld” method unless specified in drawings is not permitted without prior approval of Akashvani.
- (vi) No angle member shall have two leg flanges brought together by closing the angle.

2.1.5 Welding:

- (i) Welding, if any, shall be carried out in accordance with IS:816, IS: 2879, IS:1024 and IS:9595 amended to date as appropriate.
- (ii) Butt welding shall be carried out either by submerged arc or shielded arc welding.
- (iii) Pre-heating and post heating shall be employed as may be necessary for welding members.
- (iv) For welding of any particular type of joint, welder shall give evidence, acceptable to Akashvani of having satisfactorily completed appropriate tests as described in relevant BIS codes.

2.1.6 Tolerance:

Fabrication tolerances shall not exceed those specified in IS:7215 amended to date as applicable to group B structures.

2.1.7 Galvanizing:

- (i) All steel tower members shall be hot dip galvanized after fabrication is completed. The galvanizing of the tower members shall conform to IS:2629 amended to date, IS:4759 amended to date & IS:4736 amended to date.
- (ii) The thickness of hot dip galvanizing shall be generally **120microns** (equivalent to 860g/m² of Zinc (Coating) in accordance with IS:4759 amended to date.
- (iii) The bidder shall arrange for procurement of Zinc required for galvanizing the structure. The Zinc required for galvanizing shall conform to IS: 209 amended to date or IS:13229 amended to date.
- (iii) All galvanized members shall withstand test as per IS:2633 amended to date.
- (iv) All the bolts and nuts shall be galvanized by high temperature hot-dip galvanizing in accordance with IS:1367(Part-13) amended to date.
- (v) The plain and heavy washers and spring washers shall be hot-dip galvanized as per IS:1367 (Part-13) amended to date OR electro galvanized as per IS:1573 amended to date, IS:3655 amended to date & IS: 3203 amended to date, as applicable.

2.1.8 All the steps shall be taken by tenderer /manufacturer as per IS:9172 amended to date to prevent corrosion.

2.2. FOUNDATION:

- (i) The tenderer is advised to inspect the tower site and acquaint himself with the local terrain & site conditions, soil conditions, nature of sub soil, water table and its seasonal variations, area contours etc. and to make such local enquiries, as may be necessary for any data required by him, before quoting his rates for foundation of the

tower.

- (ii) The R.C.C foundation, tie beams etc, shall be designed and constructed in accordance with IS:11233 amended to date, IS:456 amended to date and other application codes. The minimum grade of concrete used shall be M-25.
- (iii) For the purpose of this bid, the tenderer shall quote the rates (in the commercial bid) on the basis of **8.2 MT/ Sq. M Soil Bearing Capacity (SBC) at 3 m depth**. The tenderer shall also quote for “Extra for reduced Soil Bearing Capacity (SBC) below **8.2 MT /Sq. M for every 0.55 MT/Sq. M decrease.**”
- (iv) The successful tenderer shall carry out soil tests through NABL approved Laboratory. When a test boring is conducted, all safety requirements are to be taken/ adhered from human safety aspect. Complete test observations will have to be recorded and furnished to Akashvani After taking samples, the bored hole should be closed properly.
- (v) The cement, sand and aggregate used shall be of best grade and shall be mixed in a mechanical mixer as per the design. The foundation shall be watered and cured for at least 14 days and the erection of the tower shall be commenced only after the foundations are thoroughly cured. Measurements of levels of all tower footings will be taken in the presence of Akashvani representative.
- (vi) Foundation is to be protected by provision of pitching work on sloping terrain to protect the foundation from erosion.

- (vii) In case of rock anchorage type foundation, workmanship & other requirements shall be in accordance with IS: 10270 amended to date.
- (viii) Anchorage bolts to concrete pedestal from tower is to be checked with the clauses mentioned in ACI:318-14 Chapter 17.

2.3. VERTICALITY TOLERANCES, DEFLECTION, TWIST& SWAY:

2.3.1. UNDER STILL AIR CONDITIONS:

The tower shall be vertical after erection and no straining shall be permitted to achieve this. The verticality of tower shall be within the provisions of Table-1(III) (b) of IS: 12843:1989 amended to date, viz. $\pm H/1500$ or ± 25 mm (whichever is less) for towers over 30 M height. i.e. the bottom of the line joining to the centre of the top of the tower and the centre of the base of the tower shall be within this limit. (H refers to the height of the tower).

2.3.2. UNDER MAXIMUM WIND LOAD CONDITIONS:

- (i) The horizontal deflection of the vertical axis of tower shall not be more than 1° (degree) at various levels including top, under maximum wind and other critical loading conditions. A sketch showing deflection of the vertical axis of tower as per Annexure-IV is enclosed for reference only. The deflection at top of tower shall be checked as per the provision made in latest IS:800: 2007. The reaction at base shall be unfactored.
- (ii) The angular twist shall not exceed 0.5 degree refer Annexure-V.

2.4. PROTECTION AGAINST LIGHTNING:

The tower shall be provided with a suitably designed complete system of lightning protection in accordance with provision of IS:2309 (amended to date) including necessary earthing based on the specific resistivity of the soil and sub-soil water level. The lightning protection system shall be got approved from Akashvani, before execution. Copper strip of size **50 mm × 2 mm** is to be provided for Lightning Arrester from top of the tower to the ground along with separate earthing (2 Nos. earthing).

2.5. PAINTING:

The details regarding painting of tower are given below:-

- (i) The tower shall be given one coat of ETCH primer (2 Pack) followed by two coats of Epoxy Red Oxide Zinc Phosphate Weldable primer (Two component) and two or more coats of Polyurethane Full Gloss Enamel (Two Pack) paint after erection. The tower shall be painted to have equal alternate bands of international orange and white colours with top and bottom bands painted in orange as per latest International Civil Aviation Organization Recommendations.
- (ii) The paints used in painting shall be in accordance with IS: 13213 amended to date.
- (iii) Etch primer shall conform to IS: 5666 amended to date and Epoxy Red Oxide Zinc Phosphate Weldable primer (Two components) shall conform to IS: 14506 amended to date.
- (iv) Painting shall be done in accordance with IS: 1477 Part I & II amended to date.
- (v) The minimum dry film thickness shall be 8 microns of ETCH primer, 25 microns of each coat of Epoxy Red Oxide Zinc Phosphate Weldable primer (Two component) and 35 microns of each coat of Polyurethane Full Gloss Enamel (Two Pack) paint. The overall Dry Film Thickness (DFT) should not be less than 128 microns.

2.6. EARTHING:

All the four tower legs shall be earthed individually, following the standard practice of earthing of such structures in level ground and mountainous regions (Details shall be attached with the tender). *The earth resistance of the tower earthing shall be less than 1 ohm.* A suggestive drawing No. TM-16597 for earthing is enclosed.

2.7. FACILITIES ON TOWER:

The following facilities are required to be provided on tower:

2.7.1. PLATFORM:

Provision of platform for access to the antenna and cables at different levels to be made as indicated in Annexure-II. 1.5-meter-high handrails would be provided at each level with expanded metal net for additional safety. Platform flooring will consist

of chequered plate conforming to IS:3502 amended to date and shall be designed as to take stationary and moving load of 4 persons plus equipment (weighing about 100 Kg.). At each platform "Toe-plates"(6") as a form of protection against accidental dislodging of small tools, are to be provided.

2.7.2. **LADDERS:**

- (i) An internal ladder of width not less than 450 mm starting from ground level of the tower and going up to the top with openings at all the platforms shall be provided. The ladder shall be foldable/ retractable at the ground level and length of foldable/retractable portion of ladder should not be more than 1.5M. The ladder shall be hooped type with **FREE FALL PREVENTION SYSTEM** for safety of the climbing personnel. The face on which the ladder is to be provided shall be intimated by Akashvani before the commencement of erection of tower.
The free fall prevention system shall conform to EN -353-1 amended to date (Vertex PN 700). The wire shall be steel grade 316. The shock absorber shall be installed to reduce the impact if fall on victim as well as the structure. The intermediate shall be provided at every 10 m to reduce the vibration due to wind.
- (ii) Rungs of the ladder shall be clear of any obstructions to the climber and equally spaced by not more than 300 mm.

2.7.3 **AVIATION OBSTRUCTION LIGHTS & POWER SUPPLY CABLES:**

- a) LED based Aviation Obstruction Lights including beacon light (with twin aviation obstruction light arrangement in 'ON' duty and 'STANDBY' mode with alarm monitoring) should be provided. The globes and their housings shall be strong, weather proof and of approved manufacturer. There shall be 2 lights located diagonally at each level, except the top level. The aviation obstruction lighting arrangement shall be as per latest International Civil Aviation Organization Recommendations.
- b) Power supply load of the aviation lights shall be evenly distributed on all the three phases, in order to ensure that with failure of the single phase all the lamps at each level do not go off. The power supply cable for the lights shall conform to IS: 1554 amended to date or the power supply cables for the aviation lights shall be liberally rated and shall conform to the latest Indian Standard specifications.
- c) One No., 3 Core, 6 Sq. mm copper conductor (Stranded), XLPE insulated, sheathed, weatherproof, armored Power Supply cable for Multipoint power sockets on each platform shall be supplied and laid & clamped to the cable rack. This cable shall be terminated in SP&N MCB of suitable rating in a suitable weather proof metal box at the tower base including the earthing etc. Power sockets with switches of suitable rating shall be provided and suitably mounted at each platform in weatherproof boxes.
- d) Two Nos. 4 core, suitably rated, copper conductor, XLPE insulated, sheathed, weather proof, armored power supply cable for AOL shall be provided and laid on vertical Cable Tray and fixed with cable clamps. This cable shall be terminated in TP&N MCB of suitable rating in a suitable weatherproof metal box at the tower base including the earthing etc.
- e) Distribution of supply to Aviation Obstruction Lights shall be through suitable weatherproof junction boxes with suitable mounting.
- f) The successful tenderer shall provide temporary Aviation Obstruction Lights during erection of tower as soon as the tower reaches the height of 25 meters or such heights

as prescribed in latest International Civil Aviation Organization Recommendations.

- g) A “Sun Switch” is required to be provided for AOL so that these are “ON” automatically, if sufficient sunlight is not available around tower. In no case, Sun Switch is to be installed inside a room or covered space.
- h) The details of Power Supply arrangements for aviation obstruction lights shall be provided with the tender.
- i) The LED based AOL offered shall be approved by National Physical laboratory (NPL) / ERTL / and test report for the same must be submitted with the offer as well as with the material.
- j) The detailed circuit diagram of the AOL, No. of LEDs used, details of configuration of LEDs (series parallel arrangement etc.) should be submitted with the offer.

2.7.4. CABLE RUN-WAY AND ANTENNA SUPPORTING FIXTURES:

a. Vertical Cable Rack/Tray:

The vertical cable rack for laying cables as indicated in Para 2.8.2 starting from the base to the top of the tower shall be provided. This cable rack shall be routed along the tower face or leg and should be just behind the climbing ladder or be a part of this for easy accessibility. The cable rack shall carry all the RF feeder cables, AOL & Service cables etc. It should have provisions for fixing the cable clamps. Vertical cable tray shall be provided as per drawing No. TM-16640. Vertical cable tray is to be painted in accordance with Para 2.5 above.

b. Side Mounted FM Antenna Fixtures:

Provision for fixing 100 mm inner dia. supporting seamless GI pipe category Class “C” of 20M length for FM Side Mount (Pole type) Antenna-6 Bay as per drawing No. TM-16599 shall be made on three faces of the tower. This supporting pole will be fixed in FM Side Mount antenna aperture on *one of the three faces, to be intimated at the time of erection of tower*. The fixtures of the antenna shall not foul with the cable routing from the power divider to the antenna. The above pipe shall be supplied by the tenderer as part of tower.

c. Top Mounted second channel FM Antenna Fixtures:

Provision is to be made for fixing 200 mm inner dia. seamless GI pipe category Class “C” of 12 M length as per suggestive drawing **Annexure-II** for supporting top mount VHF FM Pole Type Antenna for second channel in future.

d. Horizontal Cable Rack/Tray:

The cable run between the tower base & transmitter building shall be through a horizontal cable tray to be provided by the tenderer. The rack will be supported on 75 mm inner dia. category Class “C” G.I. pipes or 60x60x5mm G.I. angle iron structures & the rack will be covered by Semi Circular or suitable design 16 SWG G.I. sheet cover. The tenderer must quote for the horizontal cable rack on the basis of **per meter rates**. The pricing for horizontal cable rack should include the laying charges of all cables on this tray. Horizontal cable tray

shall be provided as per drawing No. TM-14453/3 and shall be connected to vertical cable tray with intersection. Pipes or angle frames should be grouted with RCC in ground as per practice and have a height of 4 Meters from the ground. Horizontal cable tray is to be painted in accordance with Para 2.5 above.

2.8. TOWER LOADING DETAILS DUE TO FM ANTENNA, MICROWAVE DISH, MOBILE ANTENNA, RF CABLES ETC. ARE GIVEN BELOW:

2.8.1. The tower shall be designed to take self-load and wind load as per details of load given below. Ice loading shall also be taken into consideration as per site requirement, if required. These are in addition to self-loading of tower.

S. No.	Description	Net weight (Kg)	Wind load (Kg)	Remarks
1.	VHF Band II FM Side Mount antenna- 6Bay (Pole Type)	600	900 @ 198 Km/hr. without ice	Weight & wind loading due to support column mounting accessories not included.
2.	VHF Band IIFM Side Mount antenna 4 Bay (Pole Type) (Provision for Future)	450	900 @ 198 Km/hr. without ice	Weight & wind loading due to support column & mounting accessories not included.

2.8.2. The following cables are to be installed on tower. Wind loading due to these may also be taken into consideration.

S. No.	Description of items with weight in Kg.	Qty.
1.	4" RF cable for FM antennas (Approx 3.50 kg/m)	2Nos.
2	1 $\frac{5}{8}$ " RF cable for FM antennas (Approx 1.50 kg/m) (Provision for Future)	2Nos.
4.	3 Core, 6 Sq. mm Power Supply cable*	1 No.

5.	Solid State Aviation Obstruction Light cable* etc. (with twin circuit arrangement)	2 Nos.
-----------	---	---------------

(* Items are to be supplied by tenderer including lugs, connectors etc.)

2.8.3. The weight & wind loading due to mounting accessories of FM Side Mount antenna(6-Bay) and 100 mm inner dia. seamless G.I. pipe category “C” of 20M length is required to be taken into consideration for loading by the tenderer as per design.

2.9. WORKMANSHIP:

- a. All workmanship for foundation work shall be in accordance with specifications, approved drawings and IS: 456 amended to date.
- b. The tenderer shall carryout excavation in all kind of soils. While excavating, excavation shall be adequately supported or formed to ensure stability of the sides and prevents any damage to the surrounding ground or structures.
- c. Excavation material suitable for re-use as backfill shall be stored within the site working area.
- d. For excavation in cohesive soil the final 150mm above foundation bottom level shall only be removed immediately prior to placing to M10 concrete pad.
- e. The tenderer shall not permit water accumulation in excavated pit.
- f. The tenderer shall carry out concrete trial mix using representative materials. Mix proportioning shall be carried out under full scale condition as per IS: 10262 amended to date. The testing shall be carried out in accordance with IS: 456 amended to date. Minimum three test cubes shall be tested.
- g. The aggregate and cement shall be proportioned by means of efficient weigh batching machines. The machine shall be maintained & cleaned periodically.
- h. The concrete shall be mixed in batches, in concrete mixing machines, which shall comply to IS Codes. Manual or hand mixing is not permitted.
- i. The tenderer shall carry out slump or other workability tests as required during concreting of work, in order to relate the degree of workability of the mix to the values obtained during the trial mix.
- j. All frameworks shall be accurately constructed to produce the correct foundation shape and shall be sufficiently strong to withstand pressure arising from concrete during placement and compaction.
- k. Reinforcement bar shall be bent and fixed in accordance with procedure specified in IS: 2502 amended to date. The high strength deformed steel bars should not be re-bent, straightened. All the reinforcement should be placed and maintained in the position as shown in the drawing by providing proper block, spacers and supporting bar.
- l. The concrete shall be placed in layer maintaining proper cover of reinforcement, which shall be compacted by vibrators.
- m. The curing & protection shall be as per BIS standards, after compaction of the concrete and shall ensure adequate protection.
- n. Backfilling shall be compacted in 300 mm layers to achieve a bulk density of not less than 1.7 MT/m³.
- o. The tenderer shall clear the site from all surplus soil and other materials before handing over the tower to Akashvani.
- p. Inspection and testing of concrete work shall be in accordance to provisions of IS: 456

amended to date.

- q. In case of rock anchorage type foundation, workmanship & other requirements shall be in accordance with IS:10270 amended to date.
- r. Testing of concrete quality is to be performed as per methods stated in IS: 516 -1959 (Reaffirmed 2004).
- s. If it is required to check the concrete strength in-site IS:1331(Part I & II, Reaffirmed 2004) method of test is to be performed.

2.10. Marking of Members

Each individual tower member shall carry a stamped mark (number) assigned to in the approved drawings. These stamping shall be done by a metal die of 16 mm size before galvanizing and on optimum depth so as to clearly legible after galvanizing. A plate indicating the name of the tower, Specification No., AT No., Manufacturer's identity and year of manufacture shall be supplied by the tenderer for display at the bottom of the tower.

2.11. Packing

The material shall be boxed or bundled for transport in the following manner:

- a. Angle shall be packed in bundles securely wrapped four times around at each end and over 900 mm with No. 9 SWG gauge wire with ends twisted tightly. Gross weight of any bundle shall not exceed 450 Kg.
- b. Angles, brackets, plates and similar small loose pieces shall be tested and bolted together in multiples, and securely wired together through holes wrapped round at least four times with No. 9 SWG steel wire and ends twisted tightly. Gross weight of each bundle shall not exceed 70 Kg.
- c. The correct numbers of bolts, nuts and washers plus extra bolts, nuts and washers for the tower shall constitute a packing unit and shall be dispatched packed in crates or wooden boxes strong enough to withstand the normal vigorous transit and handling. The various sizes of bolts, nuts and washers shall be kept in separate bags inside the main container. Each container shall carry a list of the bolts contained therein printed in water-proof ink, resistant to moisture. Weight of the container shall not exceed 70 Kg.

2.12. Marking of Packages

Each bundle or package shall have the following details marked on it.

- a. The name and address of the Consignee.
- b. The relevant marks and number of tower members or reference of bolts, nuts and small components like gusset plates, various attachments etc. for easy identification.
- c. The marking shall be stenciled in indelible ink on the top member of the bundle of tower steel and on wooden boxes or gunny bags containing smaller components.
- d. Akashvani shall, in no case, be responsible for loss of any package or bundle during transit. It shall be the responsibility of the bidder to replace the lost items free of cost.

2.13. Additional items of works

Mounting of Antenna system:

After the erection of the tower, the tenderer shall also mount FM Side Mount antenna- 6 Bay (Pole Type), RF cable, junction boxes etc. on the tower. The antenna system and RF feeder cables will be provided by Akashvani.

For the sake of completeness of works, the tenderer may have to undertake minor/major items of works that may become necessary for the mounting of antenna system mentioned hereto.

SECTION-III

SCHEDULE OF REQUIREMENTS/MATERIALS (UN-PRICED) FOR 75 M SELF SUPPORTING LATTICE STEEL TOWER (FOR EACH SITE)

(I). SUPPLY OF MATERIAL AT SITE: (All the following items shall conform to detailed Akashvani Specification)

S. No.	DESCRIPTION	Make & Model	QTY.	UNIT
1.	Supply of 75M tower superstructure materials as per Akashvani Specification complete as required. # Quantity in Metric Ton (MT) offered to be mentioned by tenderer.		#MT	MT
2.	Supply of Vertical ladder materials with Free Fall Prevention system complete as required.		1 Lot	Lot
3.	Supply of Vertical Cable Rack/Tray materials as per specification complete as required. (Rate per meter shall be quoted)		75 M*	M
4.	Supply of Horizontal Cable Rack/Tray materials as per specification complete as required. (Rate per meter shall be quoted)		25M*	M
5.	Supply of 100 mm inner dia. category Class 'C', seamless GI pipe of 20M length.		1 Job	Job
6.	Supply of LED based Aviation Obstruction Light including beacon light (with twin aviation obstruction light arrangement in 'ON' duty and 'STANDBY' mode with alarm) along with Sun-Switch, Control Panel (with MCBs, alarm indicators etc.), Power Supply Cable and accessories etc. complete as required.		1 Set Compl ete	Set Com plete
7.	Supply of Lightning Arrester materials/arrangements including earthing materials for separate earthing (2 Nos.earthing) along with copper strip of size 50 mm × 2 mm from top of the tower to the ground with lug etc. complete as required.		1 Set Compl ete	Set Com plete
8.	Supply of 3 Core, 6 Sq.mm, Copper Conductor (Stranded), XLPE insulated, Sheathed, armoured, weather proof Power Supply Cable with lugs etc. complete as required.		100M*	M

9.	Supply of 32 A, SP&N MCB along with weather proof metal boxes with multipoint power sockets and switches at base and each platform, earth wire etc. complete as required.		1 Set Compl ete	Set Com plete
10.	Supply of tower earthing system materials for 75 M tower (4 Nos. earthing) along with copper strips as per specification.		1 Set Compl ete	Set Com plete
11.	Any other item (s) required for the completeness of the DSETC of 75 m tower. Item wise details (including part No., if any) are to be given by the tenderer.		1 Set	Set
	TOTAL OF SUPPLY (A)			

*** Length mentioned is for ranking purpose only, however actual running length at sites shall be considered for payment to Tenderer by Akashvani.**

(II). WORKS:

(All the following works shall conform to detailed Akashvani Specification)

S. No.	Description	Qty.	Unit
1.	Preparation and submission of design documents & design drawings of Foundation and Tower structure approved by any IIT/SERC along with certificate from IIT/SERC testifying the soundness and safety of design of foundation and tower structure as per Akashvani specification (in hard & soft copies) to Zonal ADG (E). (Within two Months of issue of Acceptance of Tender) - 2 Sets Complete	1 Job	Job
2.	Excavation of earth & casting of tower foundation including Supply of complete raw materials, hardware, labour, site clearance etc. as per Akashvani specification complete as required.	1 Job	Job
3.	Fabrication, Galvanizing, Erection, Testing and Commissioning of 75 M Self Supporting Lattice Steel tower at site as per Akashvani specification complete as required.	1 Job	Job
4.	Fixing of Vertical ladder with Free Fall Prevention System	1	Job

	complete as required.	Job	
5.	Fixing of Vertical Cable Rack/Tray with clamps complete as required. (Rate per meter shall be quoted).	75 M	M
6.	Fixing of Horizontal Cable Rack/Tray with clamps complete as required. (Rate per meter shall be quoted).	25 M	M
7.	Fixing of 100 NB Class 'C', seamless GI pipe of 20 M length for mounting provisions for VHF FM Antenna complete as required.	1 Job	Job
8.	Painting of tower including paint materials complete as required.	1 Job	Job
9.	Fixing of LED based Aviation Obstruction Lights along with cable & MCB complete as required.	1 Job	Job
10.	Installation of Tower Lightning Arrester and earthing work (2 Nos. earthing) along with laying of Copper strip of size 50 mm × 2 mm from top of the tower to the ground with lugs etc. complete as required.	1 Job	Job
11.	Hoisting of FM Side Mount Antenna-6 Bay complete as required	1 Job	Job
12.	Laying of RF Cable complete as required	1 Job	Job
13.	Laying of Power Supply Cable and fixing of weather proof metal boxes with Multipoint Power sockets and switches at base and each platforms, fixing of 32 A, SP&N, MCB including connections, testing etc. complete as required.	1 Job	Job
14.	Earthing work for tower (4 Nos. earthing) complete as per Akashvani specification.	1 Job	Job
15.	Soil testing with detailed report & document(s) (in soft & hard copies)	1 Job	Job
16.	Inspection and certification for structural firmness, verticality and all other design specifications by any IIT/SERC after erection of tower and submission of inspection report & certificate (s) (in hard & soft copies) to Zonal ADG (E).-2 Sets Complete	1 Job	Job
17.	Preparation and submission of completion report including photographs showing complete tower as well as each section of 15 M length from base to top, horizontal cable tray and foundation processes starting of excavation, steel layout and reinforcements etc. to leveled finished foundation and submission of the same completion report (in soft & hard copies) to: (a) Akashvani Station -1 Set (b) Zonal Office -1 Set (c) Akashvani Directorate -1 Set	1 Job	Job

18.	Pre-dispatch inspection of tower materials at the works of tenderer/tower manufacturer	1 Job	Job
19.	Any other works required for the completion of DSETC of 75 m tower. Break up details of work are to be given by the tenderer.	1 Job	Job
	<i>TOTAL OF WORKS (B)</i>		
20.	<i>Additional charges for reduced soil bearing capacity below 8.2 MT/Sq. M for every 0.55 MT/Sq. M decrease.</i>	1 Job	Job
21.	<i>Additional charges for requirement of pile foundation or any other type of foundation as approved by any IIT/SERC due to typical soil condition/water table.</i>	1 Job	Job
	<i>TOTAL OF WORKS (C)</i>		

PRASAR BHARATI
(India's Public Service Broadcaster)
DIRECTORATE GENERAL: Akashvani
(PLANNING & DEVELOPMENT UNIT)

**DRAFT ACCEPTANCE TEST PROTOCOL FOR 75 M SELF SUPPORTING
LATTICE STEEL TOWER**

Akashvani Specification No- 75M(FM TOWER)/19/May/2023-D(TD/FM)for Design, Supply, Erection, Testing and Commissioning of 75 M Self Supporting Lattice Steel tower including provisions for mounting of VHF FM Antenna and RF feeder cables etc. may be referred.

I. PRE-DISPATCH TEST/ INSPECTION PROCEDURE:

In compliance with clause 1.9, the certifying agency such as the concerned IIT/SERC should also be part of PDI along with representatives of Akashvani.

A. Raw Material:

S.No.	Description	Specification	Procedure of Verification
1.	Structural Steel for tower members like M.S. Angles, M.S. Plates etc	As per IS amended to date or equivalent as specified in Akashvani specification in relevant clauses	Verification of Quality Control (Q.C.) reports/ test certificates submitted by supplier/Manufactures. Samples may be taken at the discretion of Akashvani and tested at BIS /NABL approved lab(s) as per provisions in this regard in the relevant IS codes, for which cost shall be borne by the tenderer.

B. Manufactured component / sub-assemblies:

S.No.	Description	Specification	Procedure of Verification
1.	Tower members fabricated as per approved design including	As per IS amended to date or equivalent as	Verification of Quality Control (Q.C.) reports and checks shall be made on any chosen items for conformity with Quality Control

	Galvanizing, Fasteners, bolts, nuts and other accessories.	specified in Akashvani specification in relevant clauses	reports. Samples may be taken at the discretion of Akashvani and tested at BIS /NABL approved lab(s) as per provisions in this regard in the relevant IS codes, for which cost shall be borne by the tenderer.
--	--	--	---

C. Accessories:

S.No.	Description	Specification	Procedure of Verification
1.	Cables a. Power Supply cable b. AOL power supply cable	As per Akashvani Specification	Verification of Quality Control (Q.C.) reports/Manufactures test certificates
2.	Lightning Arresters		
3.	AOL, Sun Switch & accessories		
4.	Copper earthing material		

III: Test results and inspection report in respect of part-I (A, B, C) shall be submitted by the tenderer after inspection by the authorized inspecting officer of Akashvani.

75m. HIGH F.M. TOWER

SCALE: - N.T.S.
(FOR REFERENCE ONLY)

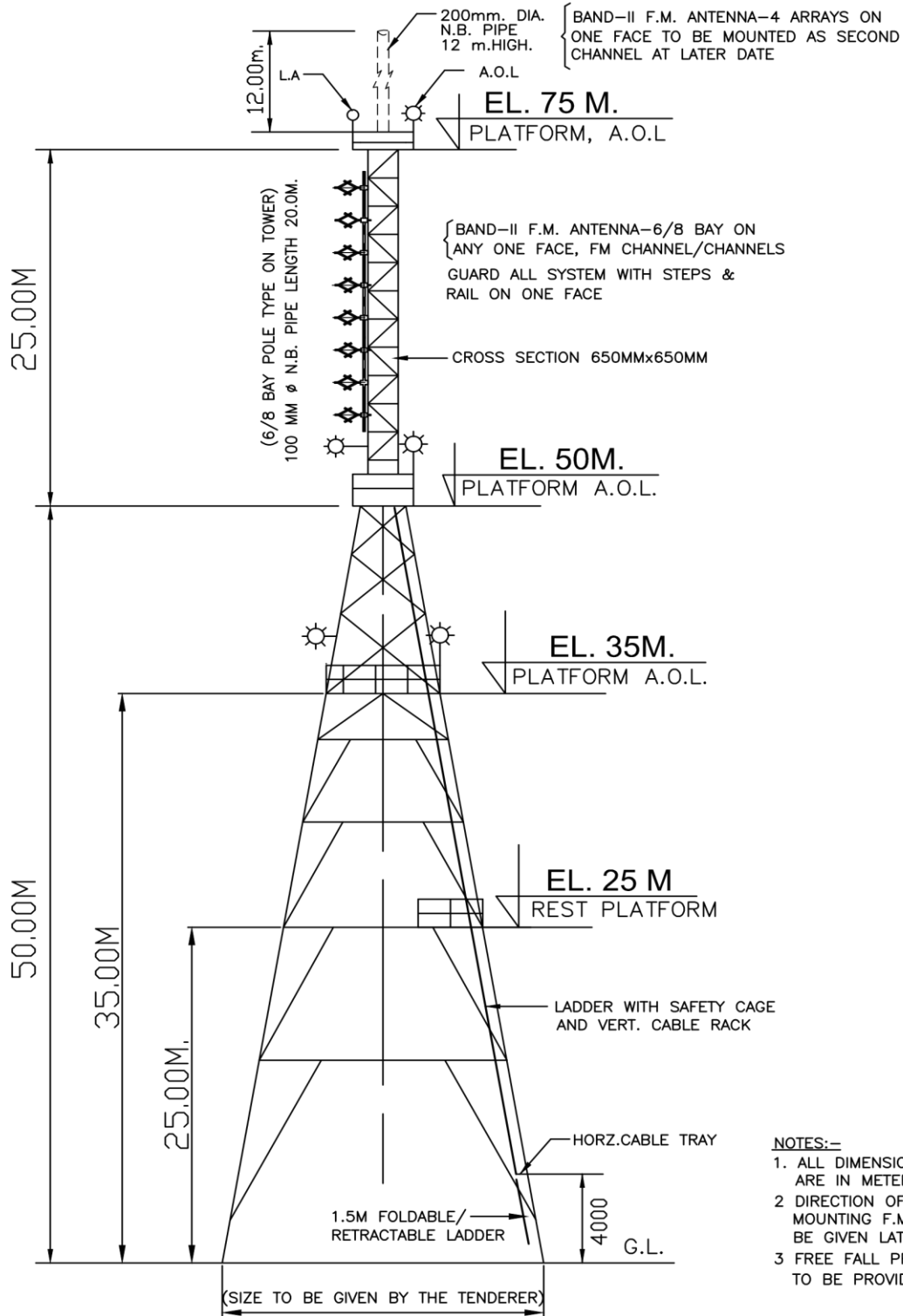

NOTES:-

1. ALL DIMENSIONS AND LEVELS ARE IN METERS.
2. DIRECTION OF TOWER FACE FOR MOUNTING F.M. ANTENNA WILL BE GIVEN LATER ON.
3. FREE FALL PREVENTION SYSTEM TO BE PROVIDED.

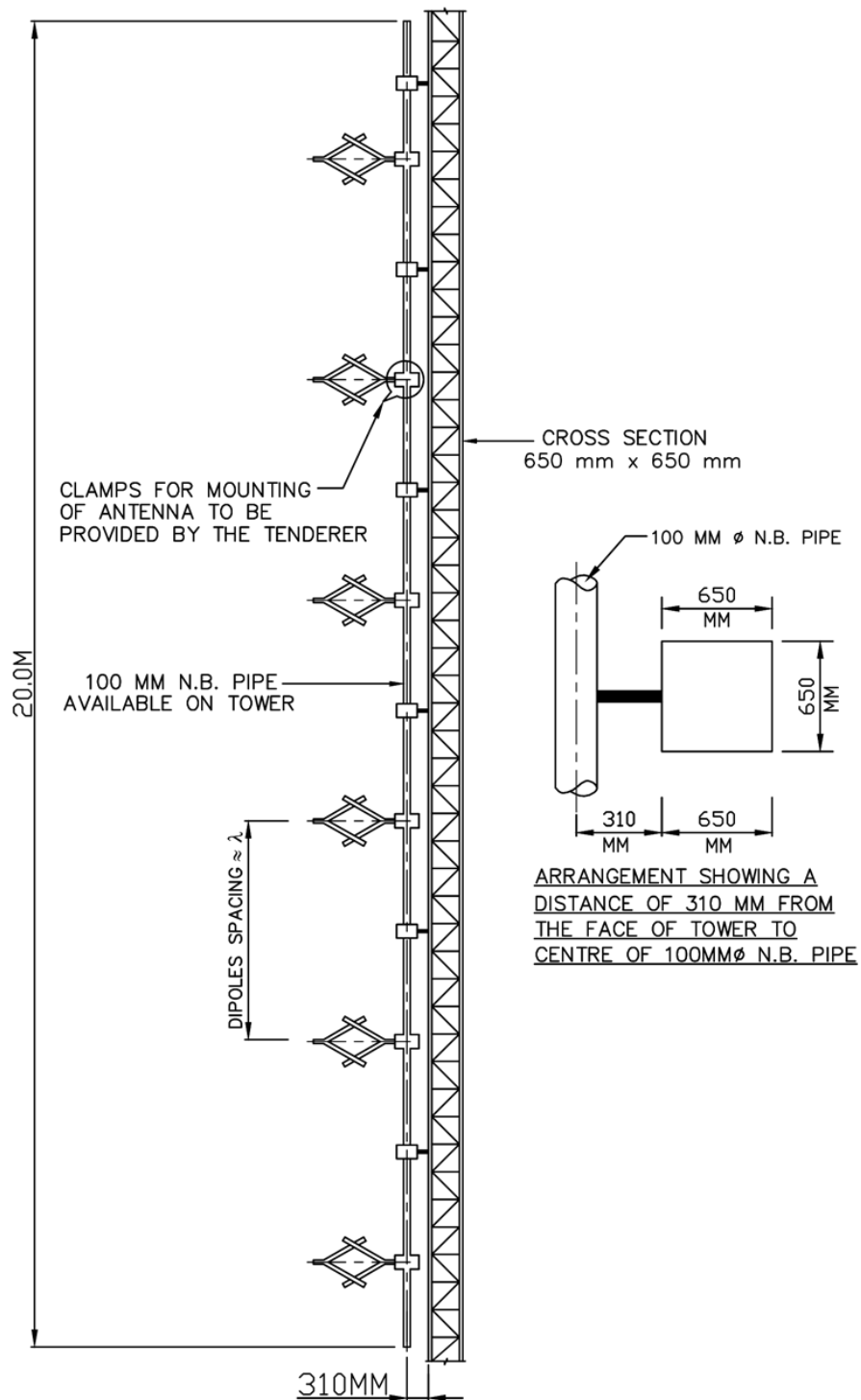

6 BAY ARRANGEMENT OF FM ANTENNA ON TOWER (DRG. FOR REFERENCE ONLY)

SCALE: - N.T.S.

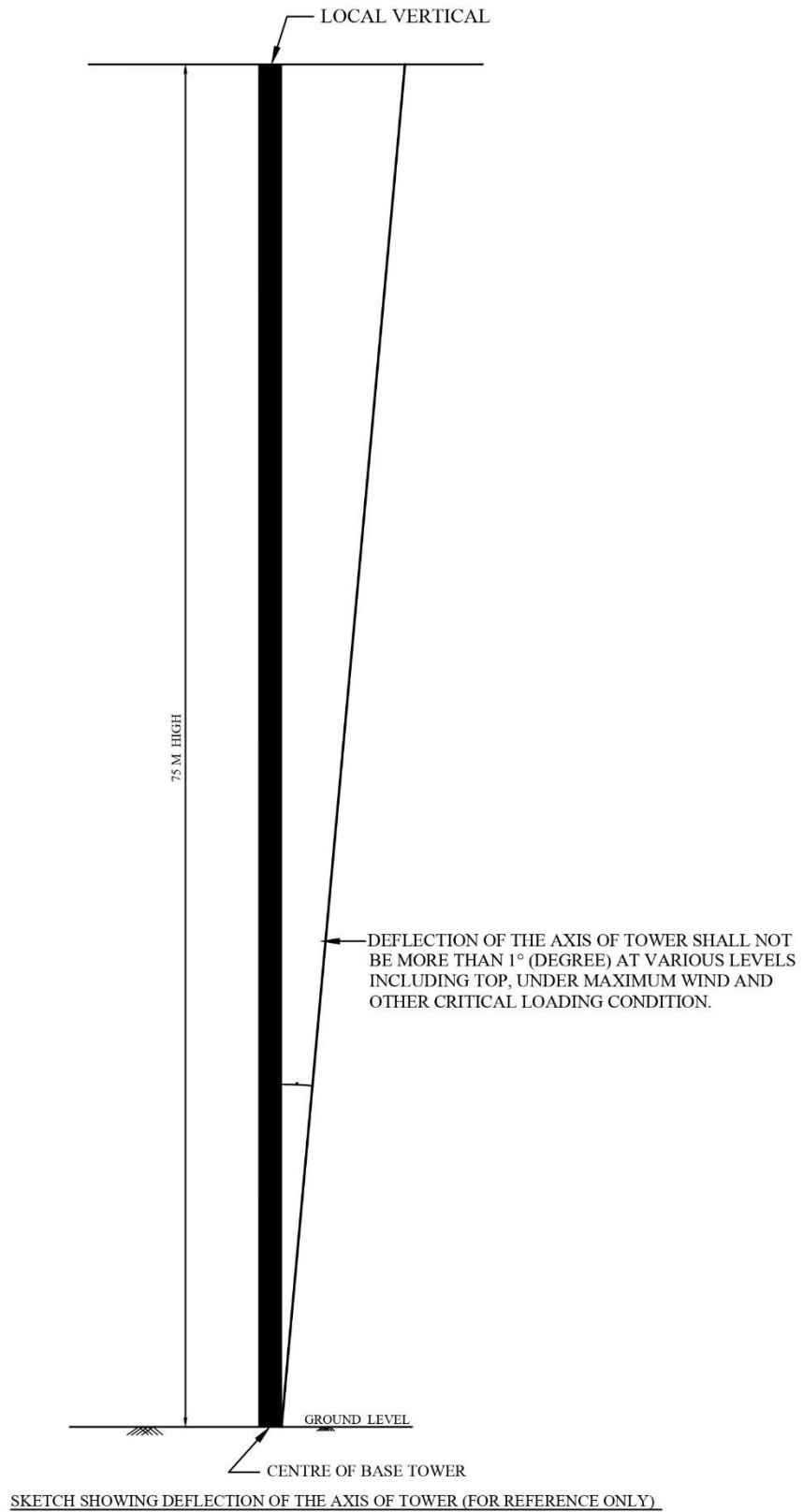
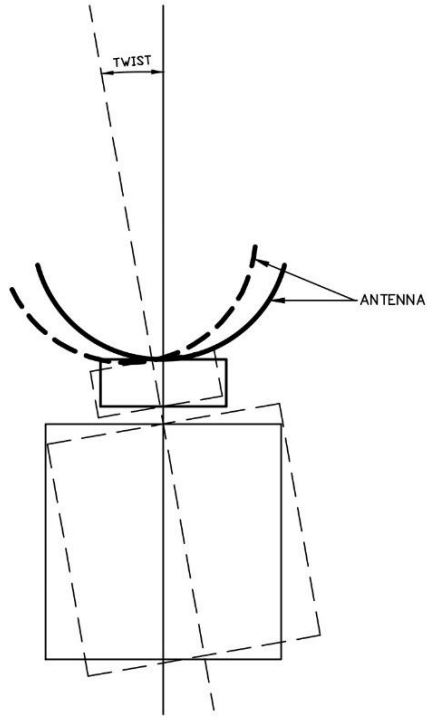
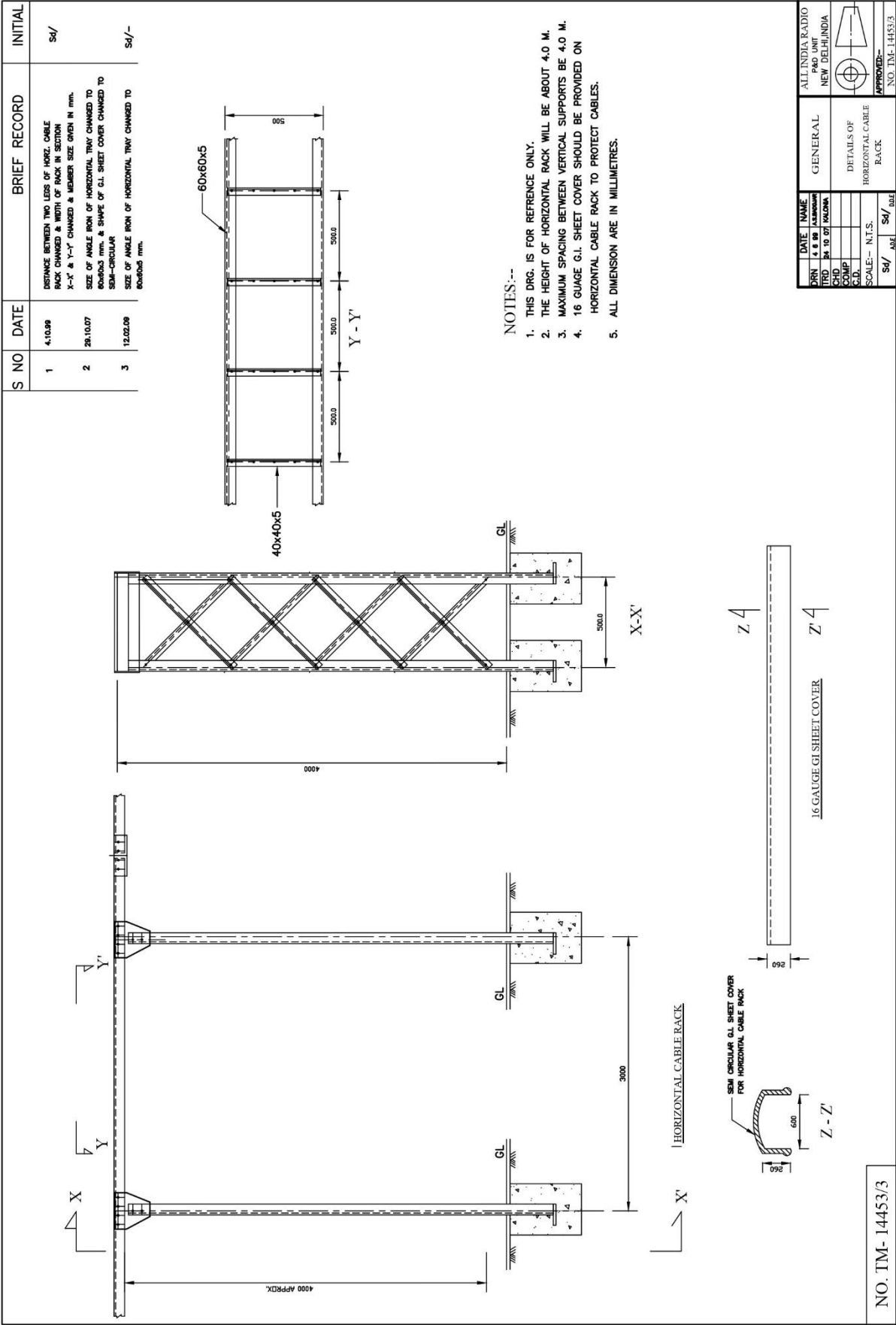

DIAGRAM EXPLAINING TWIST IN TOWER



TOP VIEW OF TOWER

ALL INDIA RADIO
P & D UNIT



- NOTES:-
1. THIS DRG. IS FOR REFERENCE ONLY.
 2. THE HEIGHT OF HORIZONTAL RACK WILL BE ABOUT 4.0 M.
 3. MAXIMUM SPACING BETWEEN VERTICAL SUPPORTS BE 4.0 M.
 4. 16 GAUGE G.I. SHEET COVER SHOULD BE PROVIDED ON HORIZONTAL CABLE RACK TO PROTECT CABLES.
 5. ALL DIMENSION ARE IN MILLIMETRES.

DATE	NAME	ALL INDIA RADIO
DRN 14.8.98	MASRUM	P&O UNIT
TRD 24.10.07	VALDAN	NEW DELHI, INDIA
CHD		
COMP		
S.D.		
SCALE - N.T.S.		
S4/	S4/	APPROVED:-
AM	AME	NO. TM- 14453/3

S. NO.	DA
--------	----

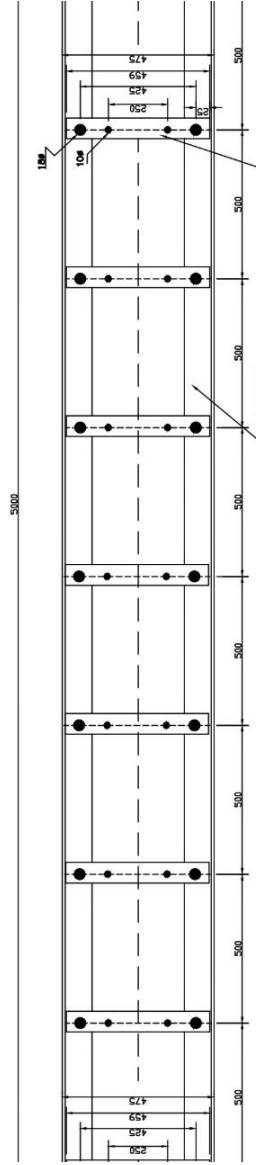
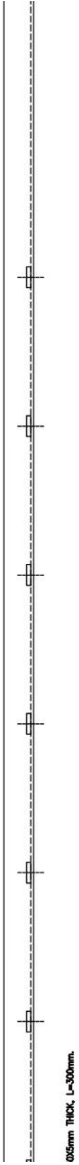

5mm THICK, L=5000mm.
 CH WITH THE INNER FINISH OF SIDE ANGLES.

: ONLY.

MM.

DATE	18	14
DRN	MAR-	
TRD		
CHD		
COMP		
C.D.		
SCALE:- M.T.S.		
		AE

(SUGGESTIVE DRAWING)

PLATE EARTHING

NOTES:-

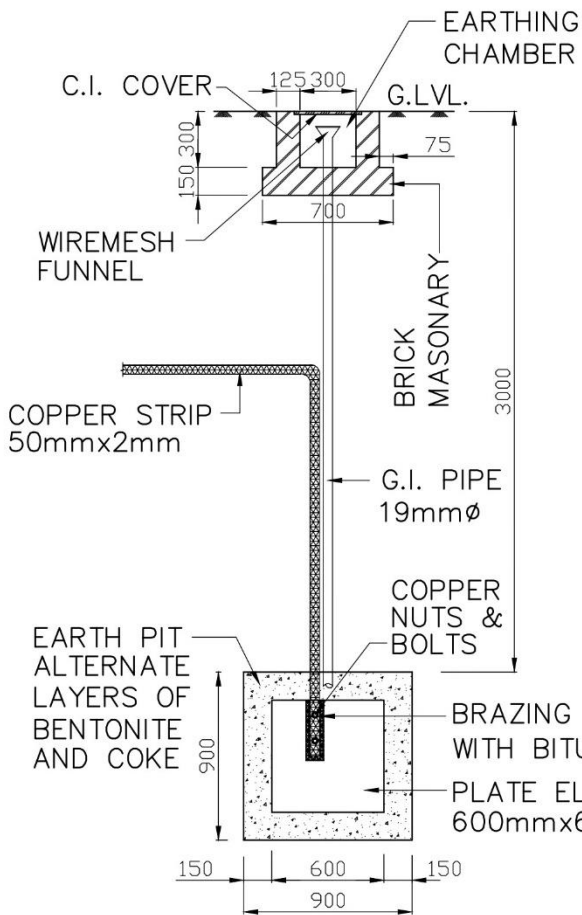
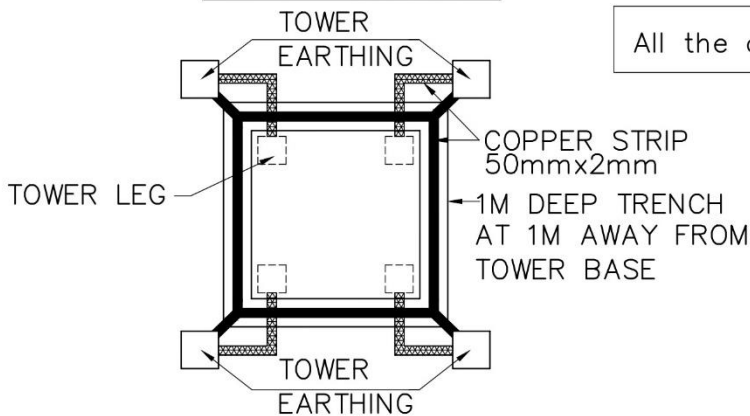

Plate Earth: Pit size of 900x900x3900 mm is excavated & copper plate of size 600x600x3.15mm is placed vertically in the excavated pit. The plate shall be connected to copper strip of 50x2mm. The bolt,nuts,check nuts & washers shall be of copper.The pit is filled with alternate layers of coke & bentonite up to a depth of 900mm & remaining portion filled with loose soil without stones. The masonry chamber at ground level of size 700x700x150mm with a hole in the middle to pass the G.I. pipe of 19mm dia with a provision for funnel & provided with C.I. frame & cover with locking arrangements. The funnel shall be fixed with wiremesh. The main hole cover shall be painted & marked with resistance of the earth.

Ring Earth: The trench all-around at 1m away from the tower base shall be excavated to a depth of 1m. 50x2mm copper strip placed at the bottom of the trench. All the copper earth electrodes shall be interconnected as shown in the drawing.

RING EARTHING



All the dimensions are in millimeters.

**ALL INDIA RADIO
P & D UNIT
NEW DELHI
DRG. No. TM-16597/1**

APPENDIX-E

6. STATE-WISE GSTINS OF ALL INDAI RADIO		
S.no.	State	All India Radio, Vellore
1	Tamilnadu	33AAAJP0288R1ZM



प्रसार भारती / Prasar Bharati
(India's Public Service Broadcaster)

आकाशवाणी महानिदेशालय/ Directorate General: Akashvani

योजना एवं विकास एकक, आकाशवाणी भवन, संसद मार्ग, नई दिल्ली, पिन - 110001

P & D Unit, Akashvani Bhawan, Sansad Marg, New Delhi-110001

ट्रान्समिटर डिज़ाइन/ Transmitter Design



File No. 9/4/2023-D (TD/FM)-75 M TOWER

Dated 06/09/2023

Subject: - Specification No. - 75 M(FM Tower)/19/ May/2023-D(TD/FM) for
DSETC of 75 M Self Supporting Lattice Steel tower.

Kindly find enclosed herewith Specification No. - 75 M(FM Tower)/19/ May/2023-D(TD/FM) for Design, Supply, Erection, Testing and Commissioning (DSETC) of 75 M Self Supporting Lattice Steel tower including provisions of mountings for installation of VHF FM Antenna etc. for FM Stations of Akashvani for information and necessary action.

Vivek Singh

(Vivek Singh)
Director Engineering (TD)
For Director General

To:

1. The Addl. Director General (SZ-BO). (Project Wing), Akashvani & Doordarshan, Swami Sivananda Salai, Chennai-600005
2. The Addl. Director General (NZ-BO), (Project Wing), Akashvani & Doordarshan, 8th Floor, Soochna Bhawan, CGO Complex, Lodhi Road, New Delhi-110003
3. The Addl. Director General (NEZ-BO), (Project Wing) Akashvani & Doordarshan, Doordarshan Complex, R.G. Baruah Road, Guwahati-781024
4. The Addl. Director General (EZ-BO), (Project Wing), Akashvani and & Doordarshan, 4th Floor, Akashvani Bhawan, Eden Garden, Kolkata-700001
5. The Addl. Director General (WZ-BO), (Project Wing), Akashvani and & Doordarshan, AOA Building, 2nd Floor, DD Complex, Worli, Mumbai 400030

Copy for kind information:

1. All Addl. Director General (E), DG: Akashvani
2. The Chief Engineer (C), Civil Construction Wing, Akashvani, 6th floor, Soochna Bhawan, CGO Complex, Lodhi Road, New Delhi-110003

Copy of for kind information and necessary action to:

1. DDG (E) (Estimate), P& D Unit, DG: Akashvani
2. DDG (E) (M&C), P& D Unit, DG: Akashvani
3. DDG (E) (Planning), P& D Unit, DG: Akashvani

4. DDG (E) (Purchase), P& D Unit, DG: Akashvani
5. DDG (E) (SMS), P& D Unit, DG: Akashvani
6. DDG (E) (SD), P& D Unit, DG: Akashvani
7. DDG (E-AIR Resources), P& D Unit, DG: Akashvani
8. DDG (E) (SCD), P& D Unit, DG: Akashvani
9. DDG (E) (TD), P& D Unit, DG: Akashvani
10. DDO (A) P& D Unit, DG: Akashvani
11. Specifications folder

A handwritten signature in black ink, appearing to read 'V. S. S. S.', written over a horizontal line.

For Director General

PRASAR BHARATI
(India's Public Service Broadcaster)
DIRECTORATE GENERAL: AKASHVANI
(PLANNING & DEVELOPMENT UNIT)

Specification for Design, Supply, Erection, Testing and Commissioning (DSETC) of 75 M Self Supporting Lattice Steel tower including provisions of mountings for installation of VHF FM Antenna etc. for FM Stations of Akashvani.

CONTENTS

S. No.	Description	Page No.
1.	A. Essential Requirement for the tender	1-2
2.	B. Essential Eligibility Criteria for tenderer	2
3.	Section-I, General Condition of Specification	3-9
4.	Section-II, Technical Specification	10-17
5.	Section-III, Schedule of Requirements/Materials (un-priced) for Design, Supply, Erection, Testing and Commissioning of 75 M Self Supporting Lattice Steel tower at each site	18-20
6.	Annexure-I, Draft Acceptance Test Protocol for 75 M Self Supporting Lattice Steel tower	21-22
7.	List of annexure/drawings enclosed with the specification.	
	(i) Annexure-II, Suggestive tower profile(general arrangement drawing)	23
	(ii) Annexure-III, Mounting arrangement of FM Side Mount Antenna-6 Bay	24
	(iii) Annexure-IV, Sketch showing deflection of the axis of tower	25
	(iv) Annexure-V, Diagram explaining Twist in tower	26
	(v) Drg. No. TM-14453/3, Details of Horizontal Cable Rack	27
	(vi) Drg. No. TM-16640, Details of Vertical Cable Rack	28
	(vii) Drg. No. TM-16597/I, A suggestive Earthing drawing	29

A. ESSENTIAL REQUIREMENT FOR THE TENDER:

- (i). The tenderer should submit schedule of Requirements/Materials (un-priced) for DSETC in the same format as given in Akashvani Specification in the technical bid, failing which the tender shall be considered incomplete and is liable to be rejected.
(ii). It is also mandatory to mention Make & Model of the offered equipment in the Schedule of Requirements/Materials (un-priced) for supply, failing which the tender shall be considered incomplete and is liable to be rejected.
- Each statement of the technical specification has to be complied with & supported by printed technical literature, technical data sheets, schematic drawings and technical manuals to assess the full merit of the offer, failing which the tender shall be considered incomplete and is liable to be rejected.
- The tenderer should submit the tender offer to Akashvani in the format given below, section wise & clause wise, in respect of all the sections of technical specifications. The tenderer/manufacturer of the tower must provide the page number reference of the Technical bid,, in column (4) of the table given below, clearly indicating the volume number also, if any, for each supporting document to verify the parametric values shown in the technical specifications compliance statement, to assess the full merit of the offer, failing which tender shall be considered incomplete and is liable to be rejected.

(Vijendra Panwar, ADE)

(O.N. Pradhan, DDE)

(Vivek Singh, Director)

(Ravindra Goyal, DDG, E)

(Aditya Chaturvedi, DDG, E)

Specification No. 75 M(FM Tower)/19/ May/2023-D(TD/FM)

S. No. of Akashvani Specification (Section wise & Clause wise) (1)	Details of Akashvani Specification (Part/ Section wise & Clause wise) (2)	Compliance (Yes/No) (3)	The Page No. of the tender offer, where the information/ supporting document is available (4)	Remarks (5)
Essential requirement for the tender				
Essential eligibility criteria for tenderer				
Section-I Clause wise				
Section-II Clause wise				
Section-III Clause wise				

4.

The complete technical specification compliance statement (section wise & clause wise) along with schedule of Requirements/Materials (un-priced) as per the format given above in clause A.(3) must be signed & stamped on each page by the tenderer/ manufacturer of the tower in the tender document. The tenderer/manufacturer of the tower should mention their name in CAPITAL LETTERS, full address with pin code, phone number, fax number, e-mail address and with their full signature.

5. The complete tender shall be page numbered.

6. The Authorization and Guarantee must be given by the tenderer/manufacturer of the tower on their letter head pad duly signed & stamped on each page. The Authorization and Guarantee other than the tenderer/ manufacturer of the tower in the tender will not be considered, failing which the tender shall be considered incomplete and is liable to be rejected.

7. Public Procurement (Preference to Make in India) Order No. P-45021/2/2017-B.E-II dated 15.06.2017 of Government of India, Ministry of Commerce and Industry, Department of Industrial Policy and Promotion shall be applicable.

8. Any change/modifications in Akashvani technical specifications format, language, technical parameters or of any other nature including the deletion of clause, words, lines in the technical compliance statement by the manufacturer of the tower/tenderer will not be acceptable to Akashvani and the tender is liable to be rejected.

B. ESSENTIAL ELIGIBILITY CRITERIA FOR TENDERER:

The essential eligibility criteria for this will be decided by the Zonal Office.

(Vijendra Panwar, ADE)

(O.N. Pradhan, DDE)

(Vivek Singh, Director)

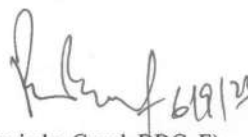
(Ravindra Goyal, DDG, E)

(Aditya Chaturvedi, DDG, E)

SECTION-I

1.0 INTRODUCTION:

Akashvani requires Self Supporting Latticed Steel 75 M tower of mean probable design life of 100 years to support FM antenna etc. The tower shall be self-supporting type having square section base out of galvanized steel sections/structures of four legs. Antenna arrangements on tower are indicated in the suggestive drawing **Annexure-II** Provision for Band II 6 bay antenna aperture for FM service shall be made on the tower. Necessary provisions in the design shall be made for mounting of the VHF Band II 4 array FM antenna in future above the Band II aperture at the top of the tower. **The mounting of VHF Band II 6 bay antenna and RF feeder cable is the present requirement. Throughout the entire aperture of band II, the outer to outer width of square cross section should be 650 mm (including splices, nuts & bolts at joints).**

- a. The tenderer shall quote for mounting of VHF Band II 6 bay FM antenna systems, feeder cables and related works/services as per details given in the subsequent paragraphs. Mounting of VHF Band II 6 bay antenna system is the present requirement. However, the tower shall be designed to take self-load and wind load for band II FM antennae 6 & 4 bay, RF feeder cables, and Power Supply cables etc. as per the details of load at **Para No. 2.8.**

1.1 SCOPE:

These specifications aims at design, fabrication, supply, erection, testing and commissioning of 75 M Self Supporting Lattice Steel tower to support VHF FM antennae as stated above, on turnkey basis.

The broad scope of the present tender includes the following as a turnkey job:-

- a. Site visit to inspect the tower site and acquaint himself with the local terrain & site conditions, soil conditions, nature of sub soil, water table and its seasonal variations etc. and make such local enquiries, as may be necessary for any data required by him, before quoting his rates. *Otherwise, the tenderer will have to give an undertaking with the tender offer that any variation in the scope of works due to site condition shall be incorporated in the offered bid and Akashvani shall not consider any extra cost on account of that.*
- b. Soil testing from NABL approved laboratory.
- c. Preparation and submission of design documents & design drawings of Foundation and Tower structure approved by any IIT/SERC along with certificate from IIT/SERC testifying the soundness and safety of design of foundation and tower structure to Zonal ADG (E) (in hard & soft copies).
- d. Preparation and submission of general arrangement drawing(s) showing all the facilities and requirements as specified in the specification to Zonal ADG (E) (in hard & soft copies).
- e. Preparation and submission of working structural drawings and submitting to Zonal ADG (E) (in hard & soft copies).
- f. Construction of Foundation for tower.
- g. Fabrication, supply, erection, testing and commissioning of tower structure and tower appurtenances/accessories including antenna apertures, internal ladders with free fall prevention system for climbing from ground to top of the tower, platforms with railings, Vertical Cable tray & Horizontal Cable tray as per actual site conditions between transmitter building up to tower, pipe for mounting of FM Side Mount antenna etc.
- h. Painting of the tower structure & cable trays.
- i. Providing protection against lightning, earthing of tower, Aviation Obstruction Lights (AOL) including Beacon light and sun-switch. The power supply cable for multi-point power sockets at various platforms, from bottom to the topmost platform of the tower, will also be supplied by the tenderer.
- j. The cables for AOL and utility outlets at various platforms shall be taken on tower on the vertical cable rack.
- k. Hauling up of FM Side Mount antenna [6-Bay VHF FM (Pole type) Antenna] and RF Feeder cable as supplied by Akashvani.

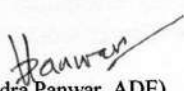
(Vijendra Panwar, ADE)

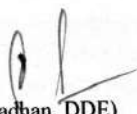
(O.N. Pradhan, DDE)

(Vivek Singh, Director)

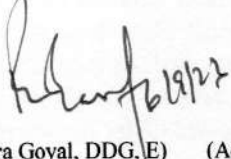
(Ravindra Goyal, DDG, E)

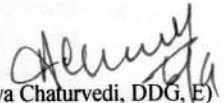

(Aditya Chaturvedi, DDG, E)

Specification No. 75 M(FM Tower)/19/ May/2023-D(TD/FM)

- l. The RF feeder cable and other cables i.e. cables for AOL, power supply etc. between the transmitter building and the tower base shall be routed on a horizontal cable tray supported on G.I. Poles/Angle Iron structure which will be supplied by the tenderer. The cables on the horizontal cable tray shall be provided with G.I. sheet cover of 16 SWG to avoid any damage to RF cable due to any falling objects.
- m. Ground has to be properly leveled after erection of the tower & cleared of all debris etc.
- n. Joint inspection with representative(s) of the firm and Akashvani.
- o. Joint inspection of pending works as pointed out during joint inspection with representative(s) of the firm and Akashvani.
- p. Inspection and certification for structural firmness, verticality and all other design specifications by any IIT/SERC **after erection of tower** and submission of inspection report & certificate(s) (in hard & soft copies) to Zonal ADG (E).
- q. Handing over of tower with completion report (in soft & hard copies) including **videography & photographs** showing complete tower as well as each section of 15 M length from base to top, horizontal cable tray and foundation processes starting of excavation, steel layout and reinforcements etc. to leveled finished foundation.
- r. Any other work necessary to complete the DSETC work as a turnkey job.

1.2 GENERAL:

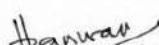
- a. General terms and conditions of contract for DSETC works including all the commercial aspects like, Packing and Packing List, Insurance and Marine Risk etc., Payment terms, Penalty/Compensation for Delay, Damages and Liabilities, Time Period and Extension for Delay, Foreclosure of Contract due to Abandonment or Reduction in Scope of Work, Cancellation of Contract in Full or Part, Recovery of Security Deposit, Performance Guarantee, Unsatisfactory Workmanship, Damages Incurred During Installation, Indian Electricity Rules, Defects, Recovery of Compensation, Ensuring Payment and Amenities, Compliance with State Labour Laws, Minimum Wages Act Compliance, Indemnifying Government against Patent Rights, Return of Surplus Material, Employment of Technical Staff and Employees, Release of Security Deposit, Safety Code etc. shall be followed by the successful tenderer as defined in the tender document in totality.
- b. *The tender shall be complete and include all minor items of work and accessories which may not have been specifically defined in this specification and schedule but which are useful and essential for the perfect assembly and completion of the tower. No extra charges will be paid for providing and installing of such items.*
- c. The successful tenderer shall make his own arrangements for power supply, water and the storage of materials and their safe custody at installation site.
- d. The successful tenderer shall make his own arrangement for employing labour-skilled and unskilled and shall make his own arrangement for providing accommodation for his labour. He should conform to all local, State laws and regulations concerning labour and their employment.
- e. The successful tenderer shall make good all damage to the purchaser's buildings, property, equipment, article etc. howsoever arising from the construction of the foundation, erection of the tower, and in the course of such work and throughout the period during which the safety of the tower is guaranteed.
- f. The successful tenderer shall indemnify and hold harmless the purchaser against all claims in respect of damages to buildings, property, articles situated nearby, not belonging to the purchaser, howsoever arising from the construction of the foundation, erection of the tower, and in the course of such work and throughout the period during which the safety of tower is guaranteed.
- g. The successful tenderer shall indemnify and hold harmless the purchaser against claims in respect of injury/any mishap to any person, howsoever arising from the construction of the foundation, erection of the tower, and in the course of such work and throughout the period during which the safety of the tower is guaranteed.
- h. The successful tenderer shall fully discharge all obligations under the Indian Workmen's Compensation Act, any local, State laws and regulations in so far as it affects the workmen in his employment.
- i. The tenderer shall be responsible for safe erection of the tower and other accessories etc. The tenderer shall take all necessary safety measures and precautions during the DSETC of the tower. Tower work shall be got done at site under the supervision of qualified representative(s) of the firm.
- j. The location of the tower at the site vis-à-vis the transmitter building will be marked by Akashvani on Site Lay Out Plan. Maximum area available, including excavation work, for tower will be 20 M × 20 M.

(Vijendra Panwar, ADE)

(O.N. Pradhan, DDE)

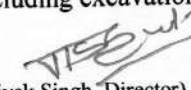
(Vivek Singh, Director)

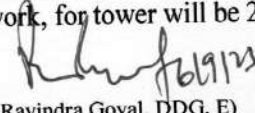
(Ravindra Goyal, DDG, E)

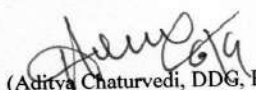
(Aditya Chaturvedi, DDG, E)

1.3 DESIGN, CALCULATION AND DRAWINGS

- a. The tower shall be designed considering probability factor based on mean probable Design life of tower structure as 100 years.
- b. The tenderer shall obtain Wind Zones data as per IS: 875 amended to date and for seismic zone data as per IS: 1893 amended to date. The above data only shall be used in the Design Calculations. However, it may be kept in view that the wind map and seismic map are approximate only and require a judicious decision on the part of the designer to provide a good design of the tower for a design life of 100 years.
- c. It may also be ensured by the tenderer that if the site falls within a short distance from another wind zone having a higher basic wind speed, the tower shall be designed as per the higher basic wind speed.
- d. The specifications indicated herein are only to guide the tenderer about the requirements of the purchaser. Detailed design of the tower from all aspects shall be got worked out by the tenderer, keeping in view the effects of local meteorological conditions like wind velocity, seismic data, temperature, codal provisions and as per good engineering practice to ensure the safety of the tower..
- e. The design of the tower shall be based on recognized principles of structural design Engineering, conforming to latest IS codes and Standard Engineering Practices. **Full responsibility regarding soundness of design including factor of safety and the execution of work rests with the tenderer.** For limit state of strength, partial safety factor for loads under worst atmospheric conditions and critical loadings shall be considered as a minimum 1.5 on any destabilizing load (including but not limited to, wind loads). If dead load contributes to the reduction of stresses or supports the stability for any particular action, suitable expected dead loads shall be considered.
- f. The overall force co-efficient for wind load on tower shall be taken from IS: 875 amended to date for Self-Supporting Lattice Steel Towers. For calculating the solidity ratio, actual obstruction area of tower shall be considered. Separate Wind obstructing areas shall be taken for ladder, cable rack and platforms etc.
- g. The permissible stresses in the various structural members of tower shall be adopted from the relevant clauses of IS: 800 amended to date.
- h. Loading effect of seismic forces as per IS: 1893 amended to date and cyclonic winds and conditions of frost etc., if any, is also be taken into consideration.
- i. **Loading effect due to antenna and various accessories as given at Para/clause No. 2.8 of Section-II will be taken into consideration.**
- j. The R.C.C foundation, tie beams etc, shall be designed and constructed in accordance with IS: 11233 amended to date, IS: 456 amended to date and other application codes. The minimum grade of concrete used shall be M-25.

1.4 The tenderer must furnish the following documents/information with the tender to assess the full merit of the offer, failing which the tender shall be considered incomplete and is liable to be rejected. This is mandatory requirement.

- a. (i) The general arrangement drawing(s) showing all the facilities and requirements as specified in the specification should be attached with the offer.
(ii) Outline drawings to scale showing the assembly of the structures. These drawings should show the main dimensions including the size of main structural members, mounting centers, methods of attachment to concrete foundations and any special features of design or form.
(iii) Total weight of tower shall be given (Excluding foundation materials).
- b. Detailed information concerning design parameters such as loads due to wind effect & seismic effect, dead loads, antenna loads, combination loads considered, design philosophy along with other information which shall contain the following:
 - (i) Wind speed, terrain category, topographic factor, gust factor, risk factor etc.
 - (ii) Seismic zone factor, importance factor, response reduction factor etc.
 - (iii) Antenna loads due to VHF Band II 6 Bay (Pole Type) FM Side Mount antenna, VHF Band II 4 Bay (Pole Type) FM antenna at the top of tower.
 - (iv) Load combinations considered.

(Vijendra Panwar, ADE)

(O.N. Pradhan, DDE)

(Vivek Singh, Director)

(Ravindra Goyal, DDG, E)

(Aditya Chaturvedi, DDG, E)

Specification No. 75 M(FM Tower)/19/ May/2023-D(TD/FM)

- c. The design calculations indicating the various formulae used for design, the bearing and shear stresses used for the design of bolted sections and the factors of safety adopted for the various structural components and materials.
For limit state of strength, partial safety factor for loads under worst atmospheric conditions and critical loadings shall be considered as a minimum 1.5 on any destabilizing load (including but not limited to, wind loads). If dead load contributes to the reduction of stresses or supports the stability for any particular action, suitable expected dead loads shall be considered.
- d. Typical design load calculation with methodology due to seismic effect.
- e. Details of Bill of Materials (BOM) showing Grade Designation and Quality of steel members, weight of the tower structure, details of fasteners, nuts, washers etc. & steel used in foundation.
- f. Design forces compression/tension due to critical load combination, design of main members panel wise i.e. leg, bracing (diagonal & horizontal) with section adopted, capacity of members based on length, slenderness ratio, allowable stress with reference & formula.
- g. Deflection at top of tower and reaction at base in most critical load combinations.
- h. The detailed design of foundations for **8.2 MT/Sq. M SBC**.
- i. Complete printed technical literature/technical data sheet/schematic drawings/detailed information of LED based Aviation Obstruction Light and details of Antenna Fixtures, Pipes, Power Supply cables, paint materials, earthing etc.
- j. Detail of activity wise Bar/PERT chart with delivery schedule.
- k. The complete technical specifications (Section wise & Clause wise) compliance statement along with Schedule of Requirements/Materials (un-priced) duly signed & stamped on each page by the tenderer/tower manufacturer as per the format given above in clause A (3) of **Essential Requirement for the Tender**.
- l. Details of past experience. **Refer clause B. Essential eligibility criteria for tenderer.**

1.5 The successful tenderer shall furnish the following documents/information within two months after issue of acceptance of tender:

- (i) Soil testing with detailed report & document(s) (in hard & soft copies) -2 Sets
- (ii) Submission of general arrangement drawing(s) showing all the facilities and requirements as specified in the specification to Zonal ADG (E). (in hard & soft copies) -2 Sets
- (iii) Submission of design documents & design drawings of Foundation and Tower structure approved by any IIT/SERC along with certificate from IIT/SERC testifying the soundness and safety of design of foundation and tower structure to Zonal ADG (E). (in hard & soft copies) -2 Sets
- (iv) Detailed working structural drawings (in hard & soft copies) -2 Sets
- (v) Any other drawings for the completeness of the tower design as per Akashvani specification.

The following references shall be indicated in the above design documents & design drawings, working structural drawings, general arrangement drawings etc. while submitting to concerned Zonal Offices.

- (1) Akashvani AT No. (2) Akashvani Specification No. & (3) Approval of competent authority with signature & stamp.

After the acceptance of all working structural drawings by Zonal ADG (E), the successful tenderer shall send all working structural drawings to concerned Zonal ADG (E), concerned Akashvani Station(s) and Akashvani Directorate indicating all the references. All these working structural drawings as per Akashvani specifications must be available with all concerned offices before the start of the tower work at the site

1.6 PATENTS AND COPYRIGHTS:

The tenderer shall hold the purchaser and his employees safe, harmless and immune from any liability that may arise out of infringements of patents and copyrights associated with the design, fabrication, erection and use of the tower and its accessories.

(Vijendra Panwar, ADE)

(O.N. Pradhan, DDE)

(Vivek Singh, Director)

(Ravindra Goyal, DDG, E)

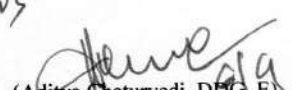
(Aditya Chaturvedi, DDG, E)

1.7 DELIVERY PERIOD:

The Delivery Period will be decided by the Zonal Office

1.8 INSPECTION & TESTS:

(a) Inspection will be done at various stages as follows: -

1. Design verification and checking of drawings before commencement of construction/fabrication.
2. Inspection of soil excavation at foundation stage.
3. Material inspection before shifting at site. (This includes reports/certificates of different quality test from BIS /NABL approved lab(s) as mentioned below.
4. Inspection during excavation for foundation and after erection of tower.
5. Checking of Verticality tolerance etc. as per Akashvani specifications at the final stage i.e. after complete erection of tower.

(b) **Test for strength of foundation:** The concrete used in the foundation should be designed as per IS:10262 amended to date. Along with the foundation, cubes should be cast, which can be tested on 7 days and 28 days to get the strength of the concrete used in the tower foundation. Reinforcement used in the foundation must also be tested in a BIS/NABL approved Labs.

(c) Pre-dispatch inspection of tower material shall have to be got done by representative(s) of Akashvani in India by giving an advance notice of **TWO WEEKS**. The certifying agency IIT/SERC that will issue certification for structural safety & firmness, verticality and all other design specifications in compliance of clause 1.9 of Section-I will also be part of PDI. Pre-dispatch inspection of tower material and subsequent inspection of erected tower shall be done as per mutually accepted test procedure, which shall be submitted and got approved from Akashvani before the supply of tower material. A draft Acceptance Test Protocol as per Annexure-I is enclosed for guidance purpose. Travelling expenses for Akashvani's representative(s) will be borne by Akashvani.

d. **Structural Steel:**

The tenderer shall procure all structural steel members from namely SAIL, TISCO and RINL. Structural steel sections not available from main producers can be procured from secondary producers subject to production of proof of manufacture of structural steel members from virgin billets produced from primary steel producers before starting fabrication work. Original copies of the test certificates of steel should be made available at the time of inspection. Samples may be taken at the discretion of Akashvani and tested at BIS /NABL approved lab(s) as per provisions in this regard in the relevant IS codes, for which cost shall be borne by the tenderer. *In case the test results indicate that the Steel arranged by the tenderer does not conform to relevant IS Codes, the same shall be rejected.*

e. **Fasteners:**

Manufacturer's routine test certificates for bolts, nuts, washers etc. as laid down in relevant BIS code shall be submitted by the tenderer at the time of inspection. Samples may be taken at the discretion of Akashvani and tested at BIS /NABL approved lab(s) as per provisions in this regard in the relevant BIS codes, for which cost shall be borne by the tenderer. In case, the test results indicate that the Fasteners arranged by the tenderer does not conform to relevant BIS Codes, the same shall be rejected.

f. **Galvanizing:**

The tenderer shall prepare a detailed galvanizing procedure including Flow Chart with control parameters and all plant standards as required above and submit to Akashvani as part of Quality Assurance Plan.

g. All standard tests, including quality control tests, in accordance with appropriate BIS standard shall be carried out unless otherwise specified herein!

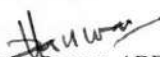
(Vijendra Panwar, ADE)

(O.N. Pradhan, DDE)

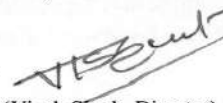
(Vivek Singh, Director)

(Ravindra Goyal, DDG, E)

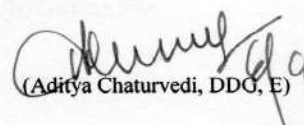

(Aditya Chaturvedi, DDG, E)

Specification No. 75 M(FM Tower)/19/ May/2023-D(TD/FM)

- h.** The following test certificates should be made available at the time of inspection. All the test certificates shall be issued by BIS /NABL approved lab(s).
1. History of metallurgy and Original copies of the test certificates of steel as per the format prescribed by BIS Code.
 2. Manufacturer's routine test certificates for bolts, nuts, washers etc. as laid down in relevant BIS code.
 3. All standard tests, including quality control tests, in accordance with appropriate BIS standard regarding galvanizing.
 4. All standard tests for welds as per BIS.
- i.** In addition to the provisions of clause regarding inspection, following shall also be included:
1. The tenderer shall keep Akashvani informed in advance about the time of starting and progress of manufacture and fabrication of various parts, so that it can be inspected, if required.
 2. The acceptance of any part or items shall in no way relieve the tenderer of any part of his responsibility for meeting the overall requirement of the specifications.
 3. Any member of the structure found not to comply with the approved drawings, shall be rejected. No member once rejected should be resubmitted for inspection except in case, where Inspecting Officer considers that the defect can be rectified.
 4. All welded structures shall be subject to a non-destructive testing as per BIS code requirement and cost should be borne by the tenderer.
 5. IS: 822 amended to date to be followed for inspection of welds and IS: 3600 (Part 1 to 9) amended to date to be followed for testing of welds.
 6. All gauges, templates, jigs, fixtures, instruments necessary for inspection and testing shall be provided by the tenderer to Akashvani for the purpose of inspection.
 7. To ensure effective in-process quality control, it is essential that the manufacturer arrange all the testing facilities for tests like, weight of zinc coating, tensile & shear strength, non-destructive testing of welds etc. The manufacturer should have proper quality assurance system in line with requirement of this specification.
 8. Each Piece of steel work shall be distinctly marked before delivery in accordance with marking diagram and shall bear such and other marks as well to facilitate erection.
 9. Each individual tower member shall carry a stamped mark (number) assigned to in the approved drawings. These stamping shall be done by a metal die of 16 mm size before galvanizing and on optimum depth so as to be clearly legible after galvanizing.

1.9 CERTIFICATION & COMPLETION REPORT AFTER ERECTION OF TOWER:

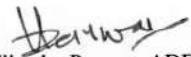
- (a) After erection of tower, the tower structure shall be inspected and certified for its structural safety & firmness, verticality and all other design specifications by any IIT/SERC. Certified inspection report with all the observations, recommendations etc. shall be submitted to Akashvani. The recommendations/suggestions will have to be incorporated by the tenderer before submitting the final completion report. All costs on this inspection and post inspection corrections, if required, for completeness of the tower shall be borne by the tenderer. The concerned IIT/SERC should be made part of PDI in order to facilitate above certification.**
- (b) The tenderer is also required to submit completion report colour printed and duly bound for the reference and record of Akashvani. A soft copy of the above must also be submitted.**

(Vijendra Panwar, ADE)

(O.N. Pradhan, DDE)



(Vivek Singh, Director)

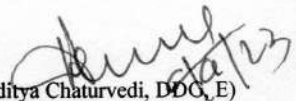

(Ravindra Goyal, DDG, E)

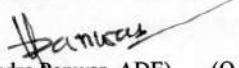

(Aditya Chaturvedi, DDG, E)

1.10 GUARANTEE:

- 1) The tenderer shall guarantee the stability, safety, durability and satisfactory mechanical behavior of the structure under specified conditions of operation, wind pressure and loading, for a period of **FIVE** years from the date of the taking over of the tower.
- 2) In the event of structural failure or any component/part of the structure within the guarantee period specified above, the tenderer shall undertake to replace the components/parts which have failed and those which were damaged as a result thereof, free of cost and bear the expenditure to be incurred for re-erection of the tower.
- 3) All the Electrical/Electronic parts/materials such as AOL, Control Panels, cabling/wiring etc. shall be guaranteed for **FIVE** years from the date of handing over.

(Vijendra Panwar, ADE)

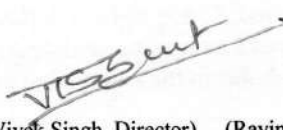
(O.N. Pradhan, DDE)

(Vivek Singh, Director)

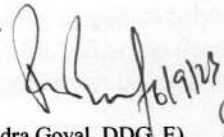
(Ravindra Goyal, DDG, E)

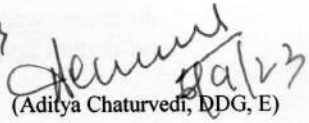
(Aditya Chaturvedi, DDG, E)

Specification No. 75 M(FM Tower)/19/ May/2023-D(TD/FM)

SECTION-II**2.0 TECHNICAL SPECIFICATIONS:**

All the BIS Specifications referred herein after shall be read with the latest amendments i.e. up to the date of submission of tender offer.

2.1 FABRICATION AND DESIGN:**2.1.1 Tower steel section:**

- (i) All tower members shall be made out of structural steel conforming to IS:2062 amended to date.
- (ii) The main members in legs, bracings, horizontals etc, **shall not be less than 6 mm thick.**
- (iii) The secondary members, like hand-rails, ladders, redundants etc. **shall not be less than 5 mm thick.**
- (iv) In case certain steel sections are not available in the market in the designed thickness, the next higher thickness available should be used.

2.1.2 Fasteners (Bolts, nuts and washers):

- (i) The tower members and other structures shall be connected/assembled by means of bolts and nuts with spring washers or locking nut.
- (ii) The quality of bolts should conform to mechanical properties as per IS:1367 amended to date and dimension to IS:6639 amended to date.
- (iii) The bolts shall be of minimum property class 8.8 as specified in IS:1367 (Part-3) amended to date.
- (iv) Nuts shall conform to IS:1363(Part-3) and appropriate property class as specified in IS:1367(Part-6) amended to date. Nuts should be double chamfered as per the requirement of IS:1363 amended to date.
- (v) The shear, bearing & tensile strength shall be in accordance with IS:800 amended to date. The fasteners shall be procured from reputed manufacturers such as UNBRAKO, TVS SUNDRAM etc.
- (vi) All the bolts and nuts shall be galvanized by high temperature hot-dip galvanizing in accordance with IS:1367(Part-13) amended to date.
- (vii) The bolts shall be as per IS:12427 & IS:4000 amended to date.
- (viii) The plain and spring washers shall be hot-dip galvanized as per IS:1367 (Part-13) amended to date OR electro galvanized as per IS:1573 amended to date & IS:3655 amended to date, as applicable.
- (ix) Nut Rotation From Snug Tight Condition:

Bolt length (as measured from underside of head to extreme end of point)	A bolt faces normal to bolt axis	One face normal to bolt axis & other face sloped not more than 1:20 (bevel washer not used)	Bolt faces slope not more than 1:20 from normal to bolt axis (bevel washers not used).
Upto including 4 dia.	1/3 turn	1/2 turn	2/3 turn
Over 4 dia. but not exceeding 8 dia.	1/2 turn	2/3 turn	5/6 turn
Over 8 dia. but not exceeding 12 dia.	2/3turn	5/6 turn	1 turn

Alternatively nuts may be tightened using a calibrated wrench so that the proof load of the bolt specified in IS: 1367 amended to date is achieved. "Snug tight is defined as the tightness attained by a few impacts of an impact wrench or the full effort of a man using an ordinary spud wrench. Following this initial operation, bolts shall be placed in remaining holes in the connection and brought to snug tight position".

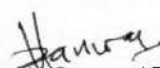
(Vijendra Panwar, ADE)

(O.N. Pradhan, DDE)

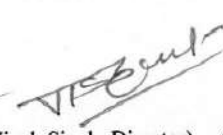
(Vivek Singh, Director)

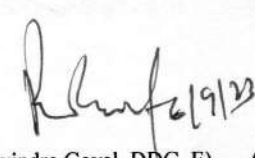
(Ravindra Goyal, DDG, E)

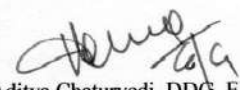
(Aditya Chaturvedi, DDG, E)

2.1.3 Fabrication:

- (i) The fabrication of tower components shall conform to IS:800 amended to date.
- (ii) All steel sections shall be fabricated as per the approved drawings.
- (iii) Gas cutting, shearing, sawing, modification of holes, welding etc. is not permitted for finished members at the site.

2.1.4 Drilling and punching:

- (i) Holes for bolts shall be drilled or punched with jig, but drilled holes shall be preferred. Punching may be adopted for thickness up to 5 mm. Tolerances regarding punched holes are as follows.
 - a. Holes must be perfectly circular and no tolerance in this respect will be permissible.
 - b. The maximum allowable difference in diameter of the holes on the two sides of plates or angles shall be 0.8 mm i.e., the allowable tolerance in punched holes should not exceed 0.8 mm on diameter.
- (ii) Drilled & punched holes must be square with the plates or angles and have their wall parallel.
- (iii) Holes on both side of the bend line in a bent member shall be drilled after bending.
- (iv) The mild steel section up to 75×75×6 may be bent by cold process up to bend angle 10° and all other angle sections and bend angles shall be bent by hot process.
- (v) The formation of bends by the "Cut & Weld" method unless specified in drawings is not permitted without prior approval of Akashvani.
- (vi) No angle member shall have two leg flanges brought together by closing the angle.

2.1.5 Welding:

- (i) Welding, if any, shall be carried out in accordance with IS:816, IS: 2879, IS:1024 and IS:9595 amended to date as appropriate.
- (ii) Butt welding shall be carried out either by submerged arc or shielded arc welding.
- (iii) Pre-heating and post heating shall be employed as may be necessary for welding members.
- (iv) For welding of any particular type of joint, welder shall give evidence, acceptable to Akashvani of having satisfactorily completed appropriate tests as described in relevant BIS codes.

2.1.6 Tolerance:

Fabrication tolerances shall not exceed those specified in IS:7215 amended to date as applicable to group B structures.

2.1.7 Galvanizing:

- (i) All steel tower members shall be hot dip galvanized after fabrication is completed. The galvanizing of the tower members shall conform to IS:2629 amended to date, IS:4759 amended to date & IS:4736 amended to date.
- (ii) The thickness of hot dip galvanizing shall be generally **120 microns** (equivalent to 860g/m² of Zinc Coating) in accordance with IS:4759 amended to date.
- (iii) The bidder shall arrange for procurement of Zinc required for galvanizing the structure. The Zinc required for galvanizing shall conform to IS: 209 amended to date or IS:13229 amended to date.
- (iii) All galvanized members shall withstand test as per IS:2633 amended to date.
- (iv) All the bolts and nuts shall be galvanized by high temperature hot-dip galvanizing in accordance with IS:1367(Part-13) amended to date.
- (v) The plain and heavy washers and spring washers shall be hot-dip galvanized as per IS:1367 (Part-13) amended to date OR electro galvanized as per IS:1573 amended to date, IS:3655 amended to date & IS: 3203 amended to date, as applicable.

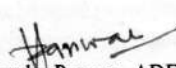
(Vijendra Panwar, ADE)

(O.N. Pradhan, DDE)

(Vivek Singh, Director)

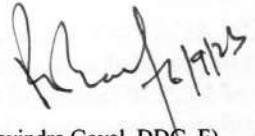
(Ravindra Goyal, DDG, E)

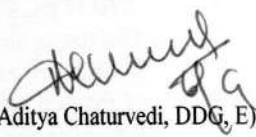
(Aditya Chaturvedi, DDG, E)

Specification No. 75 M(FM Tower)/19/ May/2023-D(TD/FM)

2.1.8 All the steps shall be taken by tenderer /manufacturer as per IS:9172 amended to date to prevent corrosion.

2.2. FOUNDATION:

- (i) The tenderer is advised to inspect the tower site and acquaint himself with the local terrain & site conditions, soil conditions, nature of sub soil, water table and its seasonal variations, area contours etc. and to make such local enquiries, as may be necessary for any data required by him, before quoting his rates for foundation of the tower.
- (ii) The R.C.C foundation, tie beams etc, shall be designed and constructed in accordance with IS:11233 amended to date, IS:456 amended to date and other application codes. The minimum grade of concrete used shall be M-25.
- (iii) For the purpose of this bid, the tenderer shall quote the rates (in the commercial bid) on the basis of **8.2 MT/ Sq. M Soil Bearing Capacity (SBC) at 3 m depth**. The tenderer shall also quote for "Extra for reduced Soil Bearing Capacity (SBC) below **8.2 MT /Sq. M for every 0.55 MT/Sq. M decrease.**"
- (iv) The successful tenderer shall carry out soil tests through NABL approved Laboratory. When a test boring is conducted, all safety requirements are to be taken/ adhered from human safety aspect. Complete test observations will have to be recorded and furnished to Akashvani After taking samples, the bored hole should be closed properly.
- (v) The cement, sand and aggregate used shall be of best grade and shall be mixed in a mechanical mixer as per the design. The foundation shall be watered and cured for at least 14 days and the erection of the tower shall be commenced only after the foundations are thoroughly cured. Measurements of levels of all tower footings will be taken in the presence of Akashvani representative.
- (vi) Foundation is to be protected by provision of pitching work on sloping terrain to protect the foundation from erosion.
- (vii) In case of rock anchorage type foundation, workmanship & other requirements shall be in accordance with IS: 10270 amended to date.
- (viii) Anchorage bolts to concrete pedestal from tower is to be checked with the clauses mentioned in ACI: 318-14 Chapter 17.

2.3. VERTICALITY TOLERANCES, DEFLECTION, TWIST & SWAY:**2.3.1. UNDER STILL AIR CONDITIONS:**

The tower shall be vertical after erection and no straining shall be permitted to achieve this. The verticality of tower shall be within the provisions of Table-1(III) (b) of IS: 12843:1989 amended to date, viz. $\pm H/1500$ or ± 25 mm (whichever is less) for towers over 30 M height i.e. the bottom of the line joining to the centre of the top of the tower and the centre of the base of the tower shall be within this limit. (H refers to the height of the tower).

2.3.2. UNDER MAXIMUM WIND LOAD CONDITIONS:

- (i) The horizontal deflection of the vertical axis of tower shall not be more than 1° (degree) at various levels including top, under maximum wind and other critical loading conditions. A sketch showing deflection of the vertical axis of tower as per Annexure-IV is enclosed for reference only. The deflection at top of tower shall be checked as per the provision made in latest IS:800: 2007. The reaction at base shall be unfactored.
- (ii) The angular twist shall not exceed 0.5 degree refer Annexure-V.

2.4. PROTECTION AGAINST LIGHTNING:

The tower shall be provided with a suitably designed complete system of lightning protection in accordance with provision of IS:2309 (amended to date) including necessary earthing based on the specific resistivity of the soil and sub-soil water level. The lightning protection system shall be got approved from Akashvani, before execution. Copper strip of size **50 mm × 2 mm** is to be provided for Lightning Arrester from top of the tower to the ground along with separate earthing (2 Nos. earthing).

(Vijendra Panwar, ADE)

(O.N. Pradhan, DDE)

(Vivek Singh, Director)

(Ravindra Goyal, DDG, E)

(Aditya Chaturvedi, DDG, E)

2.5. PAINTING:

The details regarding painting of tower are given below:-

(a). For Non-coastal Area

- (i) The tower shall be given one coat of ETCH primer (2 Pack) followed by two coats of Zinc Chromate primer and two or more coats of synthetic enamel paint after erection. The tower shall be painted to have equal alternate bands of international orange and white colours with top and bottom bands painted in orange as per latest International Civil Aviation Organization Recommendations.
- (ii) The paints used in painting shall be in accordance with IS: 2074, IS: 2932 & IS: 2933 amended to date.
- (iii) Etch primer shall conform to IS: 5666 amended to date and Priming of Zinc Chromate shall conform to IS: 104 amended to date.
- (iv) Painting shall be done in accordance with IS: 1477 Part I & II amended to date.
- (v) The minimum dry film thickness shall be 8 microns of ETCH primer, 40 microns of each coat of Zinc Chromate primer and 40 microns of each coat of synthetic enamel paint. The overall Dry Film Thickness (DFT) should not be less than 168 microns.

(b). For Coastal Area

- (i) The tower shall be given one coat of ETCH primer (2 Pack) followed by two coats of Epoxy Red Oxide Zinc Phosphate Weldable primer(Two component) and two or more coats of Polyurethane Full Gloss Enamel(Two Pack) paint after erection. The tower shall be painted to have equal alternate bands of international orange and white colours with top and bottom bands painted in orange as per latest International Civil Aviation Organization Recommendations.
- (ii) The paints used in painting shall be in accordance with IS: 13213 amended to date.
- (iii) Etch primer shall conform to IS: 5666 amended to date and Epoxy Red Oxide Zinc Phosphate Weldable primer (Two components) shall conform to IS: 14506 amended to date.
- (iv) Painting shall be done in accordance with IS: 1477 Part I & II amended to date.
- (v) The minimum dry film thickness shall be 8 microns of ETCH primer, 25 microns of each coat of Epoxy Red Oxide Zinc Phosphate Weldable primer(Two component) and 35 microns of each coat of Polyurethane Full Gloss Enamel(Two Pack) paint. The overall Dry Film Thickness (DFT) should not be less than 128 microns.

2.6. EARTHING:

All the four tower legs shall be earthed individually, following the standard practice of earthing of such structures in level ground and mountainous regions (Details shall be attached with the tender). *The earth resistance of the tower earthing shall be less than 1 ohm.* A suggestive drawing No. TM-16597 for earthing is enclosed.

2.7. FACILITIES ON TOWER:

The following facilities are required to be provided on tower:

2.7.1. PLATFORM:

Provision of platform for access to the antenna and cables at different levels to be made as indicated in Annexure-II. 1.5 meter high handrails would be provided at each level with expanded metal net for additional safety. Platform flooring will consist of chequered plate conforming to IS:3502 amended to date and shall be designed as to take stationary and moving load of 4 persons plus equipment (weighing about 100 Kg.). At each platform "Toe-plates"(6") as a form of protection against accidental dislodging of small tools, are to be provided.

(Vijendra Panwar, ADE)

(O.N. Pradhan, DDE)

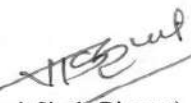
(Vivek Singh, Director)

(Ravindra Goyal, DDG, E)

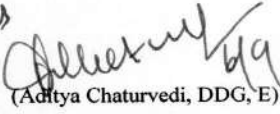
(Aditya Chaturvedi, DDG, E)

Specification No. 75 M(FM Tower)/19/ May/2023-D(TD/FM)

2.7.2. LADDERS:

- (i) An internal ladder of width not less than 450 mm starting from ground level of the tower and going up to the top with openings at all the platforms shall be provided. The ladder shall be foldable/ retractable at the ground level and length of foldable/retractable portion of ladder should not be more than 1.5M. The ladder shall be hooped type with **FREE FALL PREVENTION SYSTEM** for safety of the climbing personnel. The face on which the ladder is to be provided shall be intimated by Akashvani before the commencement of erection of tower.
The free fall prevention system shall confirm to EN -353-1 amended to date (Vertex PN 700). The wire shall be steel grade 316. The shock absorber shall be installed to reduce the impact if fall on victim as well as the structure. The intermediate shall be provided at every 10 m to reduce the vibration due to wind.
- (ii) Rungs of the ladder shall be clear of any obstructions to the climber and equally spaced by not more than 300 mm.

2.7.3 AVIATION OBSTRUCTION LIGHTS & POWER SUPPLY CABLES:

- a) LED based Aviation Obstruction Lights including beacon light (with twin aviation obstruction light arrangement in 'ON' duty and 'STANDBY' mode with alarm monitoring) should be provided. The globes and their housings shall be strong, weather proof and of approved manufacturer. There shall be 2 lights located diagonally at each level, except the top level. The aviation obstruction lighting arrangement shall be as per latest International Civil Aviation Organization Recommendations.
- b) Power supply load of the aviation lights shall be evenly distributed on all the three phases, in order to ensure that with failure of the single phase all the lamps at each level do not go off. The power supply cable for the lights shall conform to IS: 1554 amended to date or the power supply cables for the aviation lights shall be liberally rated and shall conform to the latest Indian Standard specifications.
- c) One No., 3 Core, 6 Sq. mm copper conductor (Stranded), XLPE insulated, sheathed, weatherproof, armoured Power Supply cable for Multipoint power sockets on each platform shall be supplied and laid & clamped to the cable rack. This cable shall be terminated in SP&N MCB of suitable rating in a suitable weather proof metal box at the tower base including the earthing etc. Power sockets with switches of suitable rating shall be provided and suitably mounted at each platform in weatherproof boxes.
- d) Two Nos. 4 core, suitably rated, copper conductor, XLPE insulated, sheathed, weather proof, armoured power supply cable for AOL shall be provided and laid on vertical Cable Tray and fixed with cable clamps. This cable shall be terminated in TP&N MCB of suitable rating in a suitable weatherproof metal box at the tower base including the earthing etc.
- e) Distribution of supply to Aviation Obstruction Lights shall be through suitable weatherproof junction boxes with suitable mounting.
- f) The successful tenderer shall provide temporary Aviation Obstruction Lights during erection of tower as soon as the tower reaches the height of 25 meters or such heights as prescribed in latest International Civil Aviation Organization Recommendations.
- g) A "Sun Switch" is required to be provided for AOL so that these are "ON" automatically, if sufficient sunlight is not available around tower. In no case, Sun Switch is to be installed inside a room or covered space.
- h) The details of Power Supply arrangements for aviation obstruction lights shall be provided with the tender.
- i) The LED based AOL offered shall be approved by National Physical laboratory (NPL) / ERTL / and test report for the same must be submitted with the offer as well as with the material.
- j) The detailed circuit diagram of the AOL, No. of LEDs used, details of configuration of LEDs (series parallel arrangement etc.) should be submitted with the offer.

(Vijendra Panwar, ADE)

(O.N. Pradhan, DDE)

(Vivek Singh, Director)

(Ravindra Goyal, DDG, E)

(Aditya Chaturvedi, DDG, E)

2.7.4. CABLE RUN-WAY AND ANTENNA SUPPORTING FIXTURES:

a. Vertical Cable Rack/Tray:

The vertical cable rack for laying cables as indicated in Para 2.8.2 starting from the base to the top of the tower shall be provided. This cable rack shall be routed along the tower face or leg and should be just behind the climbing ladder or be a part of this for easy accessibility. The cable rack shall carry all the RF feeder cables, AOL & Service cables etc. It should have provisions for fixing the cable clamps. Vertical cable tray shall be provided as per drawing No. TM-16640. Vertical cable tray is to be painted in accordance with Para 2.5 above.

b. Side Mounted FM Antenna Fixtures:

Provision for fixing 100 mm inner dia. supporting seamless GI pipe category Class "C" of 20 M length for FM Side Mount (Pole type) Antenna-6 Bay as per drawing No. TM-16599 shall be made on three faces of the tower. This supporting pole will be fixed in FM Side Mount antenna aperture on *one of the three faces, to be intimated at the time of erection of tower*. The fixtures of the antenna shall not foul with the cable routing from the power divider to the antenna. The above pipe shall be supplied by the tenderer as part of tower.

c. Top Mounted second channel FM Antenna Fixtures:

Provision is to be made for fixing 200 mm inner dia. seamless GI pipe category Class "C" of 12 M length as per suggestive drawing **Annexure-II** for supporting top mount VHF FM Pole Type Antenna for second channel in future.

d. Horizontal Cable Rack/Tray:

The cable run between the tower base & transmitter building shall be through a horizontal cable tray to be provided by the tenderer. The rack will be supported on 75 mm inner dia. category Class "C" G.I. pipes or 60x60x5mm G.I. angle iron structures & the rack will be covered by Semi Circular or suitable design 16 SWG G.I. sheet cover. The tenderer must quote for the horizontal cable rack on the basis of **per meter rates**. The pricing for horizontal cable rack should include the laying charges of all cables on this tray. Horizontal cable tray shall be provided as per drawing No. TM-14453/3 and shall be connected to vertical cable tray with intersection. Pipes or angle frames should be grouted with RCC in ground as per practice and have a height of 4 Meters from the ground. Horizontal cable tray is to be painted in accordance with Para 2.5 above.

2.8. TOWER LOADING DETAILS DUE TO FM ANTENNA, MICROWAVE DISH, MOBILE ANTENNA, RF CABLES ETC. ARE GIVEN BELOW:

2.8.1. The tower shall be designed to take self-load and wind load as per details of load given below. Ice loading shall also be taken into consideration as per site requirement, if required. These are in addition to self-loading of tower.

S. No.	Description	Net weight (Kg)	Wind load (Kg)	Remarks
1.	VHF Band II FM Side Mount antenna- 6 Bay (Pole Type)	600	900 @ 198 Km/hr. without ice	Weight & wind loading due to support column & mounting accessories not included.
2.	VHF Band II FM Side Mount antenna 4 Bay (Pole Type) (Provision for Future)	450	900 @ 198 Km/hr. without ice	Weight & wind loading due to support column & mounting accessories not included.

(Vijendra Panwar, ADE)

(O.N. Pradhan, DDE)

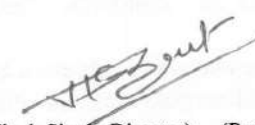
(Vivek Singh, Director)

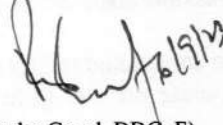
(Ravindra Goyal, DDG, E)

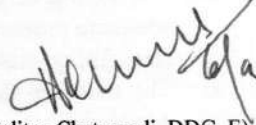
(Aditya Chaturvedi, DDG, E)

Specification No. 75 M(FM Tower)/19/ May/2023-D(TD/FM)

2.8.2. The following cables are to be installed on tower. Wind loading due to these may also be taken into consideration.

S. No.	Description of items with weight in Kg.	Qty.
1.	4" RF cable for FM antennas (Approx 3.50 kg/m)	2Nos.
2	1 $\frac{5}{8}$ " RF cable for FM antennas (Approx 1.50 kg/m) (Provision for Future)	2Nos.
4.	3 Core, 6 Sq. mm Power Supply cable*	1 No.
5.	Solid State Aviation Obstruction Light cable* etc. (with twin circuit arrangement)	2 Nos.

(* Items are to be supplied by tenderer including lugs, connectors etc.)

2.8.3. The weight & wind loading due to mounting accessories of FM Side Mount antenna (6-Bay) and 100 mm inner dia. seamless G.I. pipe category "C" of 20 M length is required to be taken into consideration for loading by the tenderer as per design.

2.9. WORKMANSHIP:

- All workmanship for foundation work shall be in accordance with specifications, approved drawings and IS: 456 amended to date.
- The tenderer shall carryout excavation in all kind of soils. While excavating, excavation shall be adequately supported or formed to ensure stability of the sides and prevents any damage to the surrounding ground or structures.
- Excavation material suitable for re-use as backfill shall be stored within the site working area.
- For excavation in cohesive soil the final 150 mm above foundation bottom level shall only be removed immediately prior to placing to M10 concrete pad.
- The tenderer shall not permit water accumulation in excavated pit.
- The tenderer shall carry out concrete trial mix using representative materials. Mix proportioning shall be carried out under full scale condition as per IS: 10262 amended to date. The testing shall be carried out in accordance with IS: 456 amended to date. Minimum three test cubes shall be tested.
- The aggregate and cement shall be proportioned by means of efficient weigh batching machines. The machine shall be maintained & cleaned periodically.
- The concrete shall be mixed in batches, in concrete mixing machines, which shall comply to IS Codes. Manual or hand mixing is not permitted.
- The tenderer shall carry out slump or other workability tests as required during concreting of work, in order to relate the degree of workability of the mix to the values obtained during the trial mix.
- All frameworks shall be accurately constructed to produce the correct foundation shape and shall be sufficiently strong to withstand pressure arising from concrete during placement and compaction.
- Reinforcement bar shall be bent and fixed in accordance with procedure specified in IS: 2502 amended to date. The high strength deformed steel bars should not be re-bent, straightened. All the reinforcement should be placed and maintained in the position as shown in the drawing by providing proper block, spacers and supporting bar.
- The concrete shall be placed in layer maintaining proper cover of reinforcement, which shall be compacted by vibrators.
- The curing & protection shall be as per BIS standards, after compaction of the concrete and shall ensure adequate protection.
- Backfilling shall be compacted in 300 mm layers to achieve a bulk density of, not less than 1.7 MT/m³.
- The tenderer shall clear the site from all surplus soil and other materials before handing over the tower to Akashvani.
- Inspection and testing of concrete work shall be in accordance to provisions of IS: 456 amended to date.

(Vijendra Panwar, ADE)

(O.N. Pradhan, DDE)

(Vivek Singh, Director)

(Ravindra Goyal, DDG, E)

(Aditya Chaturvedi, DDG, E)

- q. In case of rock anchorage type foundation, workmanship & other requirements shall be in accordance with IS: 10270 amended to date.
- r. Testing of concrete quality is to be performed as per methods stated in IS: 516 -1959 (Reaffirmed 2004).
- s. If it is required to check the concrete strength in-site IS:1331(Part I & II, Reaffirmed 2004) method of test is to be performed.

2.10. Marking of Members

Each individual tower member shall carry a stamped mark (number) assigned to in the approved drawings. These stamping shall be done by a metal die of 16 mm size before galvanizing and on optimum depth so as to clearly legible after galvanizing. A plate indicating the name of the tower, Specification No., AT No., Manufacturer's identity and year of manufacture shall be supplied by the tenderer for display at the bottom of the tower.

2.11. Packing

The material shall be boxed or bundled for transport in the following manner:

- a. Angle shall be packed in bundles securely wrapped four times around at each end and over 900 mm with No. 9 SWG gauge wire with ends twisted tightly. Gross weight of any bundle shall not exceed 450 Kg.
- b. Angles, brackets, plates and similar small loose pieces shall be tested and bolted together in multiples, and securely wired together through holes wrapped round at least four times with No. 9 SWG steel wire and ends twisted tightly. Gross weight of each bundle shall not exceed 70 Kg.
- c. The correct numbers of bolts, nuts and washers plus extra bolts, nuts and washers for the tower shall constitute a packing unit and shall be dispatched packed in crates or wooden boxes strong enough to withstand the normal vigorous transit and handling. The various sizes of bolts, nuts and washers shall be kept in separate bags inside the main container. Each container shall carry a list of the bolts contained therein printed in water-proof ink, resistant to moisture. Weight of the container shall not exceed 70 Kg.

2.12. Marking of Packages

Each bundle or package shall have the following details marked on it.

- a. The name and address of the Consignee.
- b. The relevant marks and number of tower members or reference of bolts, nuts and small components like gusset plates, various attachments etc. for easy identification.
- c. The marking shall be stenciled in indelible ink on the top member of the bundle of tower steel and on wooden boxes or gunny bags containing smaller components.
- d. Akashvani shall, in no case, be responsible for loss of any package or bundle during transit. It shall be the responsibility of the bidder to replace the lost items free of cost.

2.13. Additional items of works

Mounting of Antenna system:

After the erection of the tower, the tenderer shall also mount FM Side Mount antenna- 6 Bay (Pole Type), RF cable, junction boxes etc. on the tower. The antenna system and RF feeder cables will be provided by Akashvani.

For the sake of completeness of works, the tenderer may have to undertake minor/major items of works that may become necessary for the mounting of antenna system mentioned hereto.

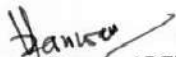
(Vijendra Panwar, ADE)

(O.N. Pradhan, DDE)

(Vivek Singh, Director)

(Ravindra Goyal, DDG, E)

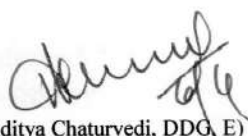
(Aditya Chaturvedi, DDG, E)

Specification No. 75 M(FM Tower)/19/ May/2023-D(TD/FM)

SECTION-III

SCHEDULE OF REQUIREMENTS/MATERIALS (UN-PRICED) FOR 75 M SELF SUPPORTING LATTICE STEEL TOWER (FOR EACH SITE)

(I). SUPPLY OF MATERIAL AT SITE: (All the following items shall conform to detailed Akashvani Specification)

S. No.	DESCRIPTION	Make & Model	QTY.	UNIT
1.	Supply of 75M tower superstructure materials as per Akashvani Specification complete as required. # Quantity in Metric Ton (MT) offered to be mentioned by tenderer.		#MT	MT
2.	Supply of Vertical ladder materials with Free Fall Prevention system complete as required.		1 Lot	Lot
3.	Supply of Vertical Cable Rack/Tray materials as per specification complete as required.(Rate per meter shall be quoted)		75 M*	M
4.	Supply of Horizontal Cable Rack/Tray materials as per specification complete as required.(Rate per meter shall be quoted)		25M*	M
5.	Supply of 100 mm inner dia. category Class 'C', seamless GI pipe of 20 M length.		1 Job	Job
6.	Supply of LED based Aviation Obstruction Light including beacon light (with twin aviation obstruction light arrangement in 'ON' duty and 'STANDBY' mode with alarm) along with Sun-Switch, Control Panel (with MCBs, alarm indicators etc.), Power Supply Cable and accessories etc. complete as required.		1 Set Complete	Set Complete
7.	Supply of Lightning Arrester materials/arrangements including earthing materials for separate earthing (2 Nos. earthing) along with Copper strip of size 50 mm x 2 mm from top of the tower to the ground with lug etc. complete as required.		1 Set Complete	Set Complete
8.	Supply of 3 Core, 6 Sq.mm, Copper Conductor (Stranded), XLPE insulated, Sheathed, armoured, weather proof Power Supply Cable with lugs etc. complete as required.		100M*	M
9.	Supply of 32 A, SP&N MCB along with weather proof metal boxes with multipoint power sockets and switches at base and each platforms, earthwire etc. complete as required.		1 Set Complete	Set Complete
10.	Supply of tower earthing system materials for 75 M tower (4 Nos. earthing) along with copper strips as per specification.		1 Set Complete	Set Complete
11.	Any other item (s) required for the completeness of the DSETC of 75 m tower. Item wise details (including part No., if any) are to be given by the tenderer.		1 Set	Set
	TOTAL OF SUPPLY (A)			

* Length mentioned is for ranking purpose only, however actual running length at sites shall be considered for payment to Tendorer by Akashvani.

(Vijendra Panwar, ADE)

(O.N. Pradhan, DDE)

(Vivek Singh, Director)

(Ravindra Goyal, DDG, E)

(Aditya Chaturvedi, DDG, E)

(II). WORKS:

(All the following works shall conform to detailed Akashvani Specification)

S. No.	Description	Qty.	Unit
1.	Preparation and submission of design documents & design drawings of Foundation and Tower structure approved by any IIT/SERC alongwith certificate from IIT/SERC testifying the soundness and safety of design of foundation and tower structure as per Akashvani specification (in hard & soft copies) to Zonal ADG (E). (Within two Months of issue of Acceptance of Tender) - 2 Sets Complete	1 Job	Job
2.	Excavation of earth & casting of tower foundation including Supply of complete raw materials, hardware, labour, site clearance etc. as per Akashvani specification complete as required.	1 Job	Job
3.	Fabrication, Galvanizing, Erection, Testing and Commissioning of 75 M Self Supporting Lattice Steel tower at site as per Akashvani specification complete as required.	1 Job	Job
4.	Fixing of Vertical ladder with Free Fall Prevention System complete as required.	1 Job	Job
5.	Fixing of Vertical Cable Rack/Tray with clamps complete as required. (Rate per meter shall be quoted).	75 M	M
6.	Fixing of Horizontal Cable Rack/Tray with clamps complete as required. (Rate per meter shall be quoted).	25 M	M
7.	Fixing of 100 NB Class 'C', seamless GI pipe of 20 M length for mounting provisions for VHF FM Antenna complete as required.	1 Job	Job
8.	Painting of tower including paint materials complete as required.	1 Job	Job
9.	Fixing of LED based Aviation Obstruction Lights along with cable & MCB complete as required.	1 Job	Job
10.	Installation of Tower Lightning Arrester and earthing work (2 Nos. earthing) alongwith laying of Copper strip of size 50 mm × 2 mm from top of the tower to the ground with lugs etc. complete as required.	1 Job	Job
11.	Hoisting of FM Side Mount Antenna-6 Bay complete as required	1 Job	Job
12.	Laying of RF Cable complete as required	1 Job	Job
13.	Laying of Power Supply Cable and fixing of weather proof metal boxes with Multipoint Power sockets and switches at base and each platforms, fixing of 32 A, SP&N, MCB including connections, testing etc. complete as required.	1 Job	Job
14.	Earthing work for tower (4 Nos. earthing) complete as per Akashvani specification.	1 Job	Job
15.	Soil testing with detailed report & document(s) (in soft & hard copies)	1 Job	Job
16.	Inspection and certification for structural firmness, verticality and all other design specifications by any IIT/SERC after erection of tower and submission of inspection report & certificate (s) (in hard & soft copies) to Zonal ADG (E).- 2 Sets Complete	1 Job	Job
17.	Preparation and submission of completion report including photographs showing complete tower as well as each section of 15 M length from base to top, horizontal cable tray and foundation processes starting of excavation, steel layout and reinforcements etc. to leveled finished foundation and submission of the same completion report (in soft & hard copies) to: (a) Akashvani Station -1 Set (b) Zonal Office -1 Set (c) Akashvani Directorate -1 Set	1 Job	Job
18.	Pre-dispatch inspection of tower materials at the works of tenderer/tower manufacturer	1 Job	Job
19.	Any other works required for the completion of DSETC of 75 m tower. Break up details of work are to be given by the tenderer.	1 Job	Job
	TOTAL OF WORKS (B)		

(Vijendra Panwar, ADE)

(O.N. Pradhan, DDE)

(Vivek Singh, Director)

(Ravindra Goyal, DDG, E)

(Aditya Chaturvedi, DDG, E)

Specification No. 75 M(FM Tower)/19/ May/2023-D(TD/FM)

20.	Additional charges for reduced soil bearing capacity below 8.2 MT/Sq. M for every 0.55 MT/Sq. M decrease.	1 Job	Job
21.	Additional charges for requirement of pile foundation or any other type of foundation as approved by any IIT/SERC due to typical soil condition/water table.	1 Job	Job
TOTAL OF WORKS (C)			

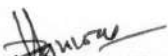
(Vijendra Panwar, ADE)

(O.N. Pradhan, DDE)

(Vivek Singh, Director)

(Ravindra Goyal, DDG, E)

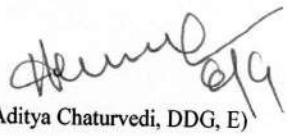
(Aditya Chaturvedi, DDG, E)

ANNEXURE-I

PRASAR BHARATI
(India's Public Service Broadcaster)
DIRECTORATE GENERAL: Akashvani
(PLANNING & DEVELOPMENT UNIT)

**DRAFT ACCEPTANCE TEST PROTOCOL FOR 75 M SELF SUPPORTING
LATTICE STEEL TOWER**

Akashvani Specification No- 75M(FM TOWER)/19/May/2023-D(TD/FM) for Design, Supply, Erection, Testing and Commissioning of 75 M Self Supporting Lattice Steel tower including provisions for mounting of VHF FM Antenna and RF feeder cables etc. may be referred.

I. PRE-DISPATCH TEST/ INSPECTION PROCEDURE:

In compliance with clause 1.9, the certifying agency such as the concerned IIT/SERC should also be part of PDI along with representatives of Akashvani.

A. Raw Material:

S. No.	Description	Specification	Procedure of Verification
1.	Structural Steel for tower members like M.S. Angles, M.S. Plates etc	As per IS amended to date or equivalent as specified in Akashvani specification in relevant clauses	Verification of Quality Control (Q.C.) reports/ test certificates submitted by supplier/Manufactures. Samples may be taken at the discretion of Akashvani and tested at BIS /NABL approved lab(s) as per provisions in this regard in the relevant IS codes, for which cost shall be borne by the tenderer.

B. Manufactured component / sub-assemblies:

S. No.	Description	Specification	Procedure of Verification
1.	Tower members fabricated as per approved design including Galvanizing, Fasteners, bolts, nuts and other accessories.	As per IS amended to date or equivalent as specified in Akashvani specification in relevant clauses	Verification of Quality Control (Q.C.) reports and checks shall be made on any chosen items for conformity with Quality Control reports. Samples may be taken at the discretion of Akashvani and tested at BIS /NABL approved lab(s) as per provisions in this regard in the relevant IS codes, for which cost shall be borne by the tenderer.

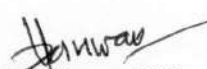
(Vijendra Panwar, ADE)

(O.N. Pradhan, DDE)

(Vivek Singh, Director)

(Ravindra Goyal, DDG, E)

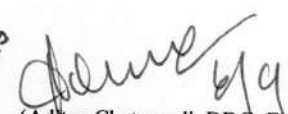

(Aditya Chaturvedi, DDG, E)

Specification No. 75 M(FM Tower)/19/ May/2023-D(TD/FM)

C. Accessories:

S. No.	Description	Specification	Procedure of Verification
1.	Cables a. Power Supply cable b. AOL power supply cable	As per Akashvani Specification	Verification of Quality Control (Q.C.) reports/Manufactures test certificates
2.	Lightning Arresters		
3.	AOL, Sun Switch & accessories		
4.	Copper earthing material		

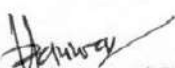
III: Test results and inspection report in respect of part-I (A, B, C) shall be submitted by the tenderer after inspection by the authorized inspecting officer of Akashvani.

(Vijendra Panwar, ADE)

(O.N. Pradhan, DDE)

(Vivek Singh, Director)

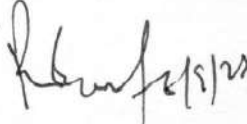

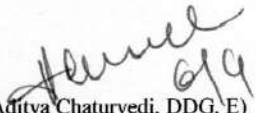
(Ravindra Goyal, DDG, E)





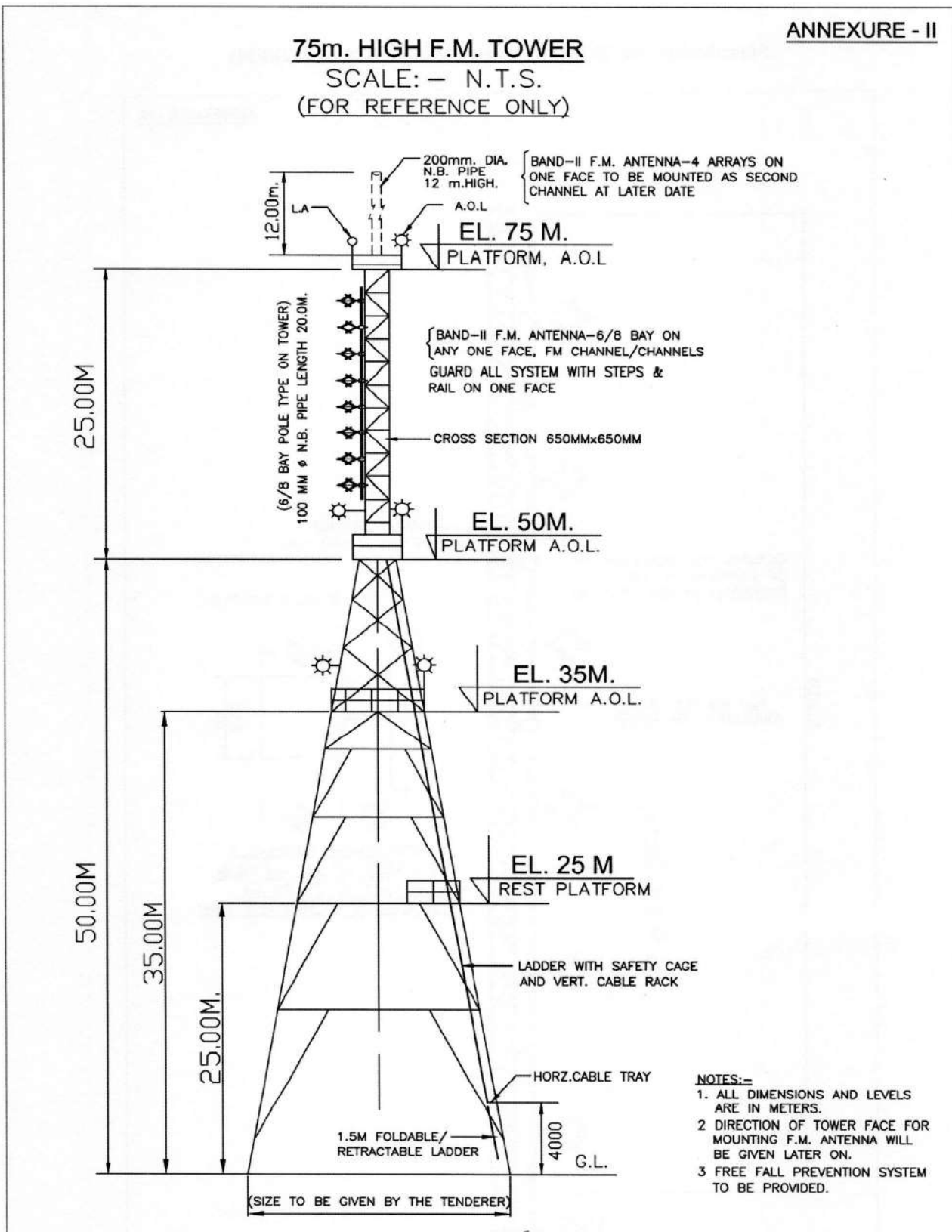

(Aditya Chaturvedi, DDG, E)

ANNEXURE - II

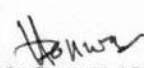
75m. HIGH F.M. TOWER

SCALE: - N.T.S.
(FOR REFERENCE ONLY)

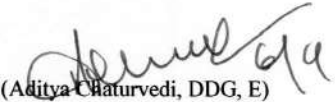

 (Vijendra Panwar, ADE)
  (O.N. Pradhan, DDE)
  (Vivek Singh, Director)
  (Ravindra Goyal, DDG, E)
  (Aditya Chaturvedi, DDG, E)

PRASAR BHARATI
(INDIA'S PUBLIC SERVICE BROADCASTER)
O/o THE ADDITIONAL DIRECTOR GENERAL (E) (SOUTH ZONE)
ALL INDIA RADIO AND DOORDARSHAN
Swamy Sivananda Salai, Chennai - 600 005

No. ADG (E)(SZ)/PUR/NIT-06/SRMST/2023-24

Date: 08.03.2024.

Amendment-I

Sub: Design, Supply, Erection, Testing and Commission (DSETC) of Self Supporting Latticed steel 75 M Tower including Provisions for mountings and installation of VHF FM Antenna etc. for FM Station at AIR, Vellore (as per Specifications)

Ref: Tender No. ADG(E)(SZ)/PUR/NIT-06/SRMST/2023-24 dated 14.02.2024

Sir,

With reference to above, the following Amendments in the tender document may be noted:

Sl. No	Tender clause	Existing	Amended as
1	Appendix-C 4. Bid Evaluation Criteria Clause 4.1.7 Tender document :P.No. 78	Delivery Period:100 days	Delivery Period : 300 days
2	Appendix-D 5.0 Description of Stores and Technical Specifications Section-I; Clause 1.7 Delivery Period Tender document :P.No. 93	The Delivery Period is 100 days	The Delivery Period is 300 days

All other terms and condition of the tender remains same

P.Padmavathi
Director (Engg)
For ADG(E)(SZ)



Signature :-
Subject : CN=A. Mahalakshmi, SERIALNUMBER=8d650ea2821221f1fae9bcf2215c76aaf42f334f530f7c9bb3ca439390f11b54, ST=Tamil Nadu, OID.2.5.4.17=600005, OID.2.5.4.20=3f47e3feb6dacda25902c88c4464d746795e3ea2d9109ce57d64556d229a0801, OU=All India Radio and DD, O=Prasar Bharati O/o ADG (E)(SZ) AIR&DD, C=IN
User ID : mahalakshmia
Serial No : 3DA09160E8
PB : rajeshwar.padmavathip
TQ : rajeshwar.padmavathip

Extension-1

PRASAR BHARATI
(INDIA'S PUBLIC SERVICE BROADCASTER)
OFFICE OF THE ADDL.DIRECTOR GENERAL (E)(SZ)
ALL INDIA RADIO & DOORDARSHAN
SWAMI SIVANANDA SALAI, CHENNAI-600 005.

No. ADG(E)(SZ)/PUR/NIT-06/SRMST/2023-24

Date:08.03.2024

Sub: Extension of due date for E-Tender enquiry -DSETC of Self -Supporting
Latticed Steel Tower at Akashvani Vellore-reg

Ref: This office enquiry letter Tender No. ADG(E)(SZ)/PUR/NIT-06/SRMST/2023-24
dated 14.02.2024.

This has reference to this office E-Tender enquiry letter referred above

The due date for opening of the tender is extended: **01.04.2024 at 15: 00 Hrs**

Please submit your quotation on or before : **01.04.2024 at 14.30Hrs**

Pre-bid meeting : **21.03.2024 at 11:00AM**

Those who have attended the pre-bid meeting earlier are exempted to attend once again

P.Padmavathi
Director (Eng)
For ADG(E (SZ)



Signature :-
Subject : CN=A. Mahalakshmi, SERIALNUMBER=8d650ea2821221f1fa
e9bcf2215c76aaf42f334f5307c9bb3ca439390f11b54, ST
=Tamil Nadu, OID.2.5.4.17=600005, OID.2.5.4.20=3f4
7e3feb6dacad25902c88c4464d746795e3ea2d9109ce57d645
56d229a0801, OU=All India Radio and DD, O=Prasar B
harati O/o ADG (E)(SZ) AIR&DD, C=IN
User ID : mahalakshmia
Serial No : 3DA09160E8
PB : rajeshwar.padmavathip
TQ : rajeshwar.padmavathip

Extension-1

PRASAR BHARATI
(INDIA'S PUBLIC SERVICE BROADCASTER)
OFFICE OF THE ADDL.DIRECTOR GENERAL (E)(SZ)
ALL INDIA RADIO & DOORDARSHAN
SWAMI SIVANANDA SALAI, CHENNAI-600 005.

No. ADG(E)(SZ)/PUR/NIT-06/SRMST/2023-24

Date:08.03.2024

Sub: Extension of due date for E-Tender enquiry -DSETC of Self -Supporting
Latticed Steel Tower at Akashvani Vellore-reg

Ref: This office enquiry letter Tender No. ADG(E)(SZ)/PUR/NIT-06/SRMST/2023-24
dated 14.02.2024.

This has reference to this office E-Tender enquiry letter referred above

The due date for opening of the tender is extended: **01.04.2024 at 15: 00 Hrs**

Please submit your quotation on or before : **01.04.2024 at 14.30Hrs**

Pre-bid meeting : **21.03.2024 at 11:00AM**

Those who have attended the pre-bid meeting earlier are exempted to attend once again

P.Padmavathi
Director (Eng)
For ADG(E (SZ)



Signature :-
Subject : CN=A. Mahalakshmi, SERIALNUMBER=8d650ea2821221f1fa
e9bcf2215c76aaf42f334f5307c9bb3ca439390f11b54, ST
=Tamil Nadu, OID.2.5.4.17=600005, OID.2.5.4.20=3f4
7e3feb6dacad25902c88c4464d746795e3ea2d9109ce57d645
56d229a0801, OU=All India Radio and DD, O=Prasar B
harati O/o ADG (E)(SZ) AIR&DD, C=IN
User ID : mahalakshmia
Serial No : 3DA09160E8
PB : rajeshwar.padmavathip
TQ : rajeshwar.padmavathip